

May

25 cents

Science and Invention

FORMERLY

**ELECTRICAL
EXPERIMENTER**

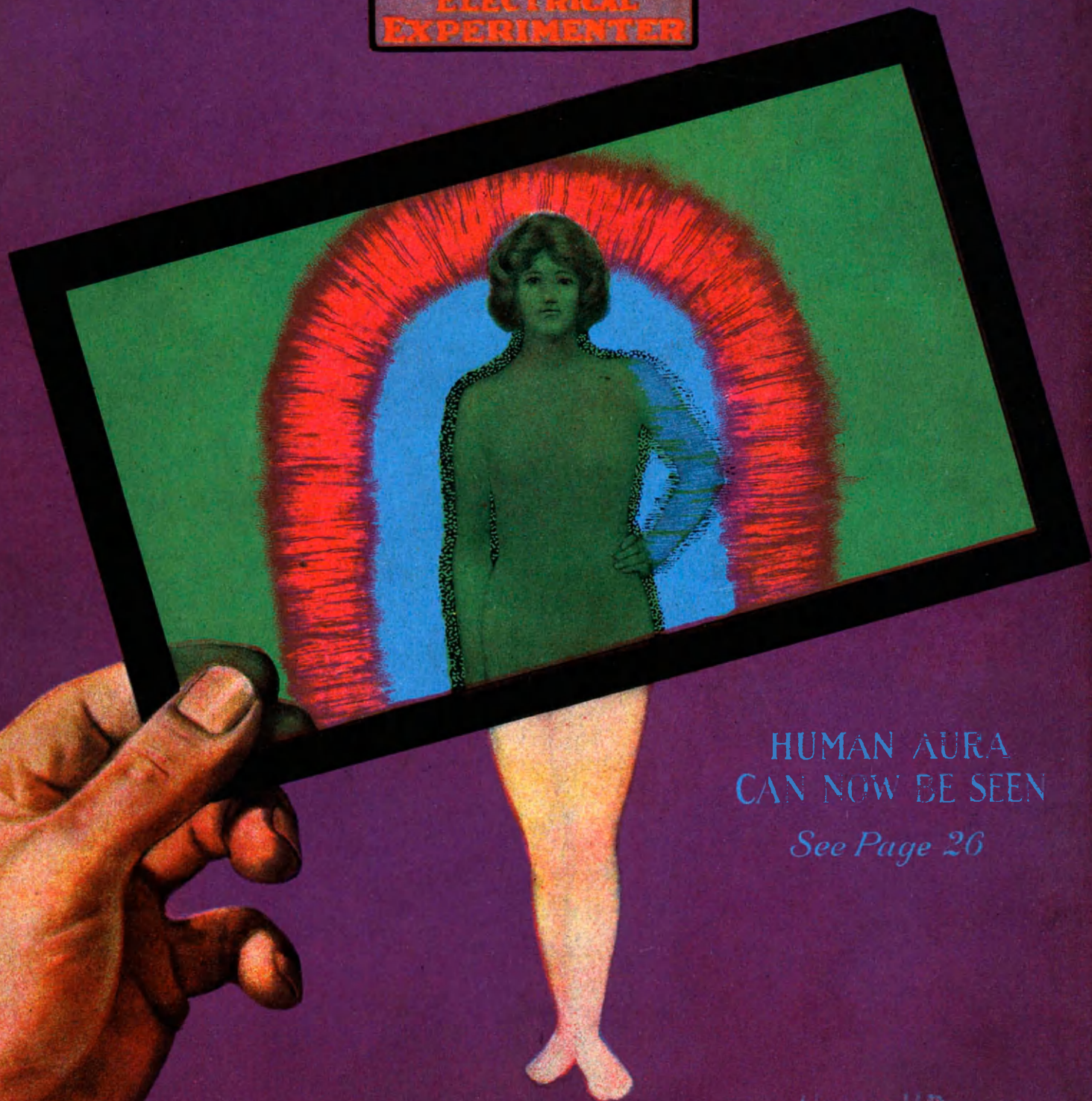

HUMAN AURA
CAN NOW BE SEEN

See Page 26

HOWARD BROWN

You, Too, Can Learn To Boss This Job

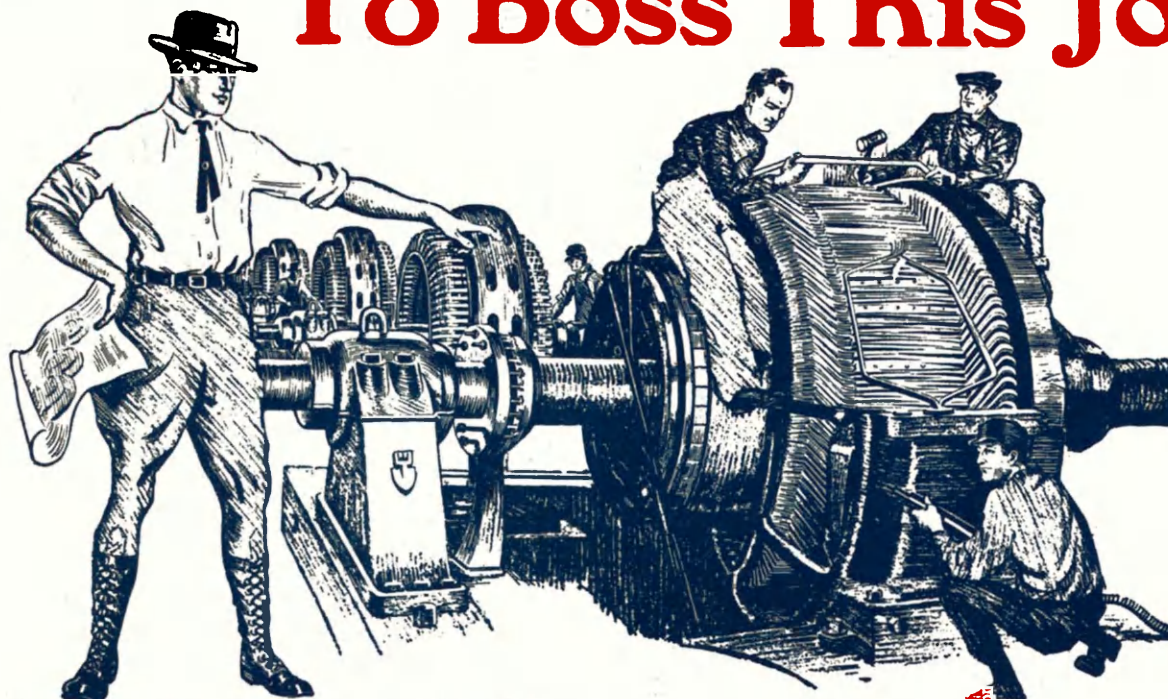

“ELECTRICAL EXPERTS” Earn \$12 to \$30 a Day

What's YOUR Future?

Trained “Electrical Experts” are in great demand at the highest salaries, and the opportunities for advancement and a big success in this line are the greatest ever known.

“Electrical Experts” earn \$70 to \$200 a week. Fit yourself for one of these big paying positions.

Be an “Electrical Expert”

Today even the ordinary Electrician—the “screw driver” kind—is making money—big money. But it's the trained man—the man who knows the whys and wherefores of Electricity—the “Electrical Expert”—who is picked out to “boss” ordinary Electricians—to boss Big Jobs—the jobs that pay.

\$3,500 to \$10,000 a Year

Get in line for one of these “Big Jobs” by enrolling now for my easily-learned, quickly-grasped, right-up-to-the-minute, Spare-Time Home-Study Course in Practical Electricity.

Age or Lack of Experience No Draw-Back

You don't have to be a College Man; you don't have to be a High School graduate. My Course in Electricity is the most simple, thorough and successful in existence, and offers every man, regardless of age, education, or previous experience the chance to become, in a very short time, an “Electrical Expert,” able to make from \$70 to \$200 a week.

I Give You a Real Training

As Chief Engineer of the Chicago Engineering Works I know exactly the kind of training a man needs to get the best positions at the highest salaries. Hundreds of my students are now earning \$3,500 to \$10,000.

Many are now successful ELECTRICAL CONTRACTORS.

Your Success Guaranteed

So sure am I that you can learn Electricity—so sure am I that after studying with me, you, *too*, can get into the “big money” class in electrical work, that I will guarantee under bond to return every single penny paid me in tuition, if, when you have finished my course, you are not satisfied it was the best investment you ever made.

FREE — Electrical Working Outfit — FREE

I give each student a Splendid Outfit of Electrical Tools, Materials and Measuring Instruments absolutely FREE. I also supply them with Drawing Outfit, examination paper, and many other things that other schools don't furnish. You do PRACTICAL work—AT HOME. You start right in after the first few lessons to WORK AT YOUR PROFESSION in a practical way.

SAVE \$45.50 BY ENROLLING NOW

You can save \$45.50 in tuition by enrolling now. Let me send you full particulars of my great Special Offer, and my Free booklet on “How to Become an Electrical Expert.”

L. L. COOKE, Chief Engineer
CHICAGO ENGINEERING WORKS

Dept. 25, 1918 Sunnyside Ave., Chicago, Ill.

L. L. COOKE
Chief Engineer
Chicago
Engineering Works
Dept. 25
1918 Sunnyside Ave.
Chicago, Ill.

Dear Sir: Send me at once full particulars of your great Special Offer; also your Free booklet on “How to Become An Electrical Expert.” No obligation on my part.

Name

Address

YOU CAN DO IT

A Direct Route to BIGGER PAY

NO MONEY DOWN

SMALL MONTHLY PAYMENTS

THROUGH ELECTRICITY you can earn more. The salary of the electrical worker is steadily advancing. Especially is this true of those who are educating themselves in the finer points of electrical practice.

Fit yourself for one of the really big jobs by knowing electrical practice complete, including inside and outside work, central stations, and the whole subject. It takes long years to do this in practice only, whereas, with the aid of the CROFT LIBRARY OF PRACTICAL ELECTRICITY it takes only months.

No matter how much nor how little you know of electricity, the Croft Library will be found of assistance every day. You will immediately recognize the fact that the author is a practical man. You will immediately see the great difference between these and other books on the subject you possess.

FREE to you a copy of Dudley's **CONNECTING INDUCTION MOTORS** (regular price) . . \$2.50

A. M. Dudley of the Westinghouse Elect. & Mfg. Co., one of the leading authorities on induction motor windings, has written a book on this subject that in two months has made a wonderful sales record. It is a book every electrical repairman, armature winder and trouble worker will want.

If you will send us your order for the CROFT LIBRARY on the coupon below, we will give you Mr. Dudley's great book *free* after your first payment on the CROFT LIBRARY. This offer is limited and may be withdrawn at once. Take advantage of it now.

READ THIS—

McGraw-Hill Book Co., Inc.,
370 Seventh Avenue,
New York.

Gentlemen: The CROFT LIBRARY OF ELECTRICITY more than came up to my expectations. I have been in the electrical business for fifteen years, and know the general run of electrical books. Terrell Croft's Library is the best I have had the pleasure of examining.

Yours truly,
EDWARD T. HOFF,
713 3rd Ave.,
Asbury Park, N. J.

The Croft Library adheres closer to actual practice than anything of the kind ever attempted. It is the most complete set of books on electricity ever published. It is clearest in word and illustration. It has no equal in everyday helpfulness. It cannot be compared in any way with other sets of books on this subject.

Just return the coupon—

Fill out the coupon below and return to us. We will immediately send the eight volumes, charges prepaid, for ten days' use in connection with your work. Don't bother to send any money. We do not want a cent from you until you have examined the books and decided that they are a direct route to bigger pay. Then you can send us \$3 in 10 days and \$3 per month until the special price of \$27.50 is paid.

After your first payment, we will send you FREE Mr. Dudley's great book.

McGraw-Hill Book Co., Inc.

370 Seventh Avenue, New York

MAIL THIS COUPON TO-DAY

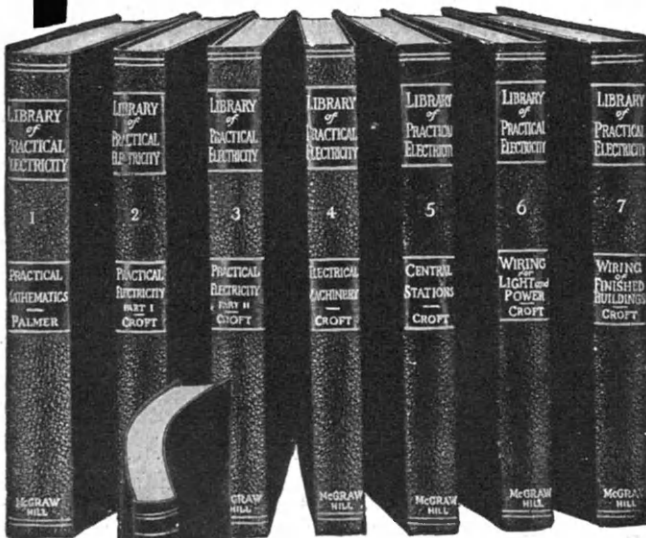

AND THIS—

Electricity, from the simplest principles to complete and economical operation of a central station.

Motors, generators, armatures, commutators, transformers, circuits, currents, switchboards, distribution systems.

Electrical machinery of every type, installation, operation and repair.

Wiring for light and power. How to do it mechanically perfect, in accordance with the National Electrical Code.

Wiring of finished buildings, Underwriters' and municipal requirements. How to do the complete job from estimating it, to completion.

Illumination in its every phase. The latest and most improved methods of lighting. Lamps and lighting effects.

A complete course in mathematics as applied to work. A course which refreshes your mind, and gives you mastery of all the shortcuts in figuring.

Electrical practice complete. Electrical practice as experts know it. Electrical practice by experts.

McGraw-Hill Book Co., 370 Seventh Ave., New York

Gentlemen:—Please send me the Library of Practical Electricity (shipping charges prepaid), for 10 days' free examination. If satisfactory, I will send \$3 in ten days and \$3 per month until \$27.50 has been paid. If not wanted, I will write you for return shipping instructions. Immediately upon receipt of my first payment, send me free of charge Dudley's **CONNECTING INDUCTION MOTORS**.

Name.....
Home Address.....
City and State.....
Where Employed.....
Occupation..... **S&I 5-21**

Vol. IX
Whole No. 97

Science and Invention

May, 1921
No. 1

FORMERLY
ELECTRICAL EXPERIMENTER
233 FULTON STREET-NEW YORK

Published by Experimenter Publishing Company, Inc., (H. Gernsback, Pres.; S. Gernsback, Treas.; R. W. DeMott, Sec'y) 233 and 236 Fulton Street, New York

Two Billion Horsepower

IT has been known for over a century that the moon moves faster in the heavens now than in former ages. Halley and Laplace pointed this out over a hundred years ago. No one seemed to have a theory that accounted correctly for the phenomenon in all its phases.

In tracing back famous eclipses that occurred in antiquity, for instance those during the days of ancient Greece and Rome, astronomers were impressed by the fact that these eclipses when reckoned backward occurred at different times of the day than the calculations called for. There could be only one logical explanation and that is—the earth revolves slower now than in former centuries. As the earth's and the moon's movements are closely inter-related due to universal gravitation, it follows as a matter of course that the moon must accordingly move faster in the heavens. The amount, in effect, is a 21" shift to the east in a century.

Now, the slowing up of the earth's rotation is almost imperceptible. Even with our present day precision instruments, the difference in time can hardly be noticed over a period extending thru a decade. The calculated figure amounts to only 1/80 of a second in 1,000 years!

But what is the cause of this slowing up of the earth's rotation? Sir George Darwin pointed out years ago that it can be due solely to the friction produced by our tides. The earth is a body in motion just like any other moving body. Accordingly it is subject to the same laws of mechanics as other bodies in motion. Friction means production of heat and friction will slow up a moving body no matter what its size. Sir George thus calculated very correctly that tidal friction would cause the earth to slow up. At the same time these tidal forces drive the moon further out

in its orbit (7½ feet per century) with the result that the length of the lunar month, now approximately 28 days, increases gradually.

Sir George's theory has been confirmed recently by actual data collected painstakingly over a period of many years by three English scientists, Dr. Fotheringham, Dr. Taylor and Dr. Jeffreys. These scientists not only reckoned backwards many historical eclipses of the sun and the moon, but they found by calculation that the friction produced by tidal action would perfectly account for the slowing up of the earth.

Altho this "braking" action of the tidal friction upon the earth seems almost microscopic if we consider only the effect of slowing up the earth at the rate of an insignificant 1/800 of a second in 100 years, the power required to produce this result is gigantic.

Consider the earth which is a globe almost 8,000 miles in diameter, spinning at the rate of over 1,000 miles per hour at the equator. Then let us figure out how many horsepower it takes to slow up this globe at the rate of only 1/800 of a second in 100 years.

The startling answer is 2½ billion horsepower acting continuously for the entire 100 years. Such figures overwhelm our imagination, but they are readily proved. Altho absolutely accurate figures as to tidal forces all over the world are unavailable, a rough estimate can be made readily. Tidal forces out in the ocean are not very great and the friction there amounts to only a small fraction compared to that set up along our shores. You only have to calculate the amount of horsepower developed along our shores for a mile and then multiply this by the total shore mileage thruout the world. You will then find that 2½ billion horsepower is a rather conservative figure.

H. GERNSBACK.

CONTENTS FOR MAY, 1921

HUMAN AURA CAN NOW BE SEEN.....	Front Cover	COBWEBS!.....	By William M. Butterfield	24
DOUBLE AND TRIPLE-DECKING BUSY CITY THOROFARES.....	11	BOULDER CANYON DAM, 700 FT. HIGH AND 300 FT. WIDE.....		25
SCIENCE IN STAGELAND—FALLING AIRPLANE SCENE FROM "THE BROKEN WING" AND NAVAL BATTLE SCENE FROM "IN THE NIGHT WATCH".....	12	THE HUMAN AURA.....	By Hugo Gernsback, Member of the American Physical Society.	26
MONSTERS OF LONG AGO.....	By Dr. E. Bade	14	OPTICAL LENSES COLORED BY ELECTRICITY.....	29
RAISING SUNKEN SHIPS IN 24 HOURS.....	16	NATURE'S FLY TRAPS.....	By Harry Rosenthal, Consulting Engineer.	34
DR. HACKENSAW'S SECRETS.....	17	POPULAR ASTRONOMY—SUN SPOTS AND THE WEATHER.....	By Isabel M. Lewis, M.A.	36
No. 1—Secret of Artificial Reproduction. By Clement Fezzandé.		MOTOR HINTS—\$50.00 PRIZE CONTEST.....		38
BOMBING PLANES VERSUS BATTLESHIPS.....	18	HOME MECHANICS.....	Conducted by William M. Butterfield.	39
COLLOIDAL FUEL.....	21	HOME ELECTRICS—COMPUTING YOUR ELECTRIC LIGHT BILL.....	By G. L. Hoadley, M.E.	40
By Prof. T. O'Connor Sloane, Ph.D., LL.D.		AN ELECTRIC TURN-TABLE FOR PRIVATE GARAGES—BURGLAR ALARMS FOR SAME.....	By H. Johnstone.	41
RADIUM IN CANCER TREATMENT.....	22			
By Joseph H. Kraus.				

SCIENCE AND INVENTION is published on the 25th of each month at 233 Fulton Street, New York. There are 12 numbers per year. Subscription price is \$3.00 a year in U. S. and possessions. Canada and foreign countries \$3.50 a year. U. S. coin as well as U. S. stamps accepted (no foreign coin or stamps). Single copies, 25 cents each. A sample copy will be sent gratis on request. Checks and money orders should be drawn to order of EXPERIMENTER PUBLISHING CO., Inc. If you change your address notify us promptly, in order that copies are not miscarried or lost.

All communications and contributions to this journal should be addressed to: Editor, SCIENCE AND INVENTION, 233 Fulton Street, New York. Unaccepted contributions cannot be returned unless full postage has been in-

cluded. ALL accepted contributions are paid for on publication. A special rate is paid for novel experiments; good photographs accompanying them are highly desirable.

SCIENCE AND INVENTION. Monthly. Entered as second-class matter at the New York Post Office under Act of Congress of March 3, 1879. Title registered at the Patent Office. Copyright, 1921, by E. P. Co., Inc. New York. The Contents of this Magazine are copyrighted and must not be reproduced without giving full credit to the publication.

SCIENCE AND INVENTION is for sale at all newsstands in the United States and Canada; also at Brentano's, 37 Avenue de l'Opera, Paris. Member of the Audit Bureau of Circulation.

MASTERS KEY

THERE IS A

El Paso, Texas, Oct. 1, 1917.
 MR. CHARLES F. HAANEL, St. Louis, Mo.
In Re "The Master Key."

My dear Mr. Haanel: The value of an idea is determined by its application. Pragmatism has long since spread beyond the confines of Missouri. The world to-day insists on being shown.

The lash of circumstances and the logic of events are, more than ever, impelling men to think. Whether an idea be a new process for picking cabbages or an old process for preserving kings, we are from Missouri.

A philosophy of life having as its base blind optimism; a religion that won't work seven days a week, or a proposition that isn't practical, appeals to the intelligent not at all. It is results that we want and the acid test is, will it work?

The Master Key qualifies. It is the most lucidly scientific statement of "Truth" that I have seen. It reconciles rationalism and religion; illumines economic determinism and the materialistic conception of history, and is an infallible guide to understanding. It contains in condensed form the substance of an entire library on science. Its teaching, if consistently applied, will make a man healthy, wealthy and wise. Its distribution is superlatively work in itself. Those who wish to think intelligently will find it invaluable.

Intelligence rules. Desire intelligently directed is a creative force which automatically causes its object to manifest on a material plane. It is the law. Let him that hath an ear to hear, hear.

Yours truly,
 CHAS. A. HEARD.

May 15, 1918.

Dear Mr. Haanel: Ever since I have been old enough to read, I have been reading metaphysical literature. I have waded ears deep through the books from all ages, all lands, all schools.

I have rejected tons of lies, oceans of misconceptions, an entire universe of false deductions. I have found grains of truth in mines of folly, and words of truth in a single grain. The pursuit was interesting in itself, and I do not regret the time spent upon it. But it was a genuine surprise to read your Master Key System and find within, the essence of all that I had read, with much more added thereto.

In this extraordinary system you have sifted the true from the false; you have given in concrete form all that is worth while in many schools of philosophy.

You have placed arcane truths into the hands of the uninitiated as weapons they can learn to use without danger to themselves. I congratulate you. You are doing mankind a service.

Yours very sincerely,
 CHARLES F. OURSLER.
 501 Fifth Avenue, New York City, N. Y.

Detroit, Mich., May 28, 1917.

Dear Sir: The words, "Your world will change as if by magic, the moment you realize the marvelous power within your control," page 6, I have underlined. They state a fact, a real live fact; and to me this is the most wonderful, the most important fact of all—that one may put this knowledge to an immediate test, that one may, after learning of this power, proceed to apply it with a definite knowledge as to results.

W. M. HOWE.

THE LOWE OBSERVATORY

Edgar Lucien Larkin, Director

Los Angeles, Cal., Dec. 6, 1916.

MR. CHAS. F. HAANEL, St. Louis, Mo.
 Dear Sir: Your booklet, Master Key, ought to be expanded into a book. Its teachings that Mind is the all-dominating creative force is precisely in line with the wonders of the most recent psychology. All persons having desks should have this pamphlet thereon. And it would be a fitting pocket companion.

EDGAR LUCIEN LARKIN.

WHICH can unlock the secret chambers of success; can throw wide the doors which seem to bar men from the treasure house of nature, and bids those enter and partake who are wise enough to understand and broad enough to weigh the evidence; firm enough to follow their own judgment and strong enough to make the sacrifice exacted.

Chattanooga, Tenn., Feb. 22, 1918.

The Master Key is wonderful, it has brought about a most remarkable change in my environment, attitude toward life, mental and physical condition. I am an entirely new person and improving daily, discouragement, lack of ambition, physical ills, mental distress, and fear are things of the past.

I cannot find words that express my gratitude for all that the Master Key has done for me. With heartfelt thanks to you, I am

Yours sincerely,
 R. J. ARNOLD.

Washington, D. C., Dec. 29, 1916.

Dear Sir: Your little booklet entitled, "The Master Key," has been received and I had great pleasure in studying it carefully. It is a very clear and concise, yet forceful presentation of the big subject handled and shows a very wide study of the absolute teachings and deep understanding of the same.

Very truly yours,
 JAMES LEE BOST.

"I am able to extract from this system all that can be made known by the finite mind relative to origin, evolution, destiny and the much-mooted riddle of the Universe."

"I can hardly grasp the full significance of the facts. The vastness of this subject is so overwhelming it seems a life-time of effort could never fathom all its possibilities."

"The Master Key is too modest a title for such a stupendous revelation."

"I have found the Key and with it each day am opening the store-house of wisdom and success, of which for many years I was utterly ignorant."

New York City, May 20, 1918.

Dear Mr. Haanel:
 The Master Key system deals with the energy which creates things, rather than with the manipulation of things after they are created, because of this fact it is absolutely limitless.

Very sincerely,
 E. FLOOD.

Charles F. Haanel, 203 Howard Bldg., St. Louis, Mo.

Enclosed find 10c for which send me descriptive literature concerning the Master Key System.

Name

Address

Post Office.....State



NOTE—Tomorrow, today will be yesterday. Mail the Coupon TODAY! NOW!

I CAN TEACH ELECTRICITY

TO A 15-YEAR-OLD BOY. I CAN INCREASE THE PAY OF ANY ELECTRICAL WORKER OR ENGINEER IN HIS OWN HOME DURING SPARE TIME ~ R.G.Streuber



The World Technical Institute announces the Streuber Course on Practical Electrical Engineering, a study course without higher mathematics.

If the Streuber Course on Practical Electrical Engineering can teach a 15-year-old boy the correct principles of electrical practice, the conquest must necessarily be very simple and easy for the man of twenty to fifty.

Perfection Reached in Teaching Electricity.

Perfection in teaching the practical side of electricity by the home study method has been reached. A quarter of a century was spent in perfecting the automobile. Thousands of models were discarded before perfection was reached. It is the same with the methods of teaching practical electricity.

Twenty Years of Observation.

The founders of the World Technical Institute have studied the problems in teaching electricity for twenty years. The progress of students, from start to complete mastery, has been observed and studied throughout these twenty years. Simple methods of teaching the hardest problems in practice is the result of this observation and study. The Streuber Course on Practical Electrical Engineering finally divulges the secrets of success in the world of electricity. It actually prepares the student for responsible positions, gets him ready to immediately step into a big-paying place, where ordinarily a man arrives only after years of hard work at low pay. It is nothing short of a revolution in the methods of teaching electricity.

Earn at Least \$10 Per Day.

Without electricity civilization would stagnate. The progress of mankind depends upon it. Its thousands upon thousands of applications and uses are being multiplied with such rapidity that since its inception there has been a shortage of properly trained men for the many responsible positions it affords. This shortage of trained men is likely to continue indefinitely. The Streuber Course not only fits men for the positions paying an average of \$10 per day, but for the bigger places which employers everywhere find it so hard to fill.

Who is R. G. Streuber?

R. G. Streuber is probably better fitted to teach the practical side of electricity than any man in America. He understands both the theory and practice of electricity. He was formerly instructor in one of the most important resident electrical schools of America, where only practical men are turned out. Here he taught up wards of one thousand men, from fifteen to fifty years of age. Later he was called to the Westinghouse Company to take up important duties in their switchboard engineering department. Still later he was connected with the National Conduit and Cable Company as electrical engineer.

We can train you in electricity in your own home, no matter how little you know, where you are situated, nor how limited your means.

The most unusual methods of teaching electricity ever conceived are now brought right into your own home. You can now become a highly paid man with a trade or profession, during your spare time, without losing a day from your regular work. This course fits you for actual electrical work. It is built around practice itself. It is up to the minute.

Free Coupon Brings all the Facts.

Any man, regardless of his age, location, education or means, should know the facts about the Streuber Course at once. Time is money. Find out now just how quickly R. G. Streuber can make of you a highly paid man.

Immediately upon receipt of the attached coupon we will see that you are supplied with every detail in regard to this unusual Course. We will tell you HOW it has revolutionized the methods of teaching electricity. You obligate yourself in no way by returning the coupon. We employ no agents to sway you in your judgment. You digest the information in your own home, without outside interference.

If you have made up your mind to earn a man's pay, to succeed in the world of electricity, get this coupon in the mails at once.

WORLD TECHNICAL INSTITUTE

FULLER BUILDING, JERSEY CITY, N. J.

Also publishers of the famous Sheppard Course on Navigation, which has been included in the U. S. Navy Education System.

YOUR FUTURE LIES IN THIS FREE COUPON

Name
Address.....
..... S&I 5-21

How I Turned Work into Play at \$200⁰⁰ a Week

By David Beach

The Amazing Story of a Bookkeeper Who Without Any Previous Experience Learned the One Great Secret of Drawing in His Spare Time and Cashed in on it

"—and—Four times my former salary, and my own boss, all for a few hours delightful study!"

A man was talking to his companion in the seat behind me on my homebound train. The cheerful enthusiasm of the voice sounded vaguely familiar. I turned to see who the speaker might be. To my surprise I recognized him as Bob Enright, an old friend, whom I had not seen since we were junior clerks together at Sims, Foreman & Co.

"What is it all about, Bob?" I asked, as soon as greetings were over, "what is this wonderful job of yours? Tell me about it."

Bob laughed. "You'll be surprised when I tell you, Dave—I am an artist! Not another Rembrandt, perhaps—"

"Artist?"—I interrupted, "what do you mean?"

"Just that—A-R-T-I-S-T—I do some of the stuff you see in the Sunday newspaper magazine sections."

"But, what the dickens, Bob—when did you learn how to do it!—What have you been doing—studying abroad?"

"Not a bit of it—learned right here in U. S. A., at my own fireside. It took me only about an hour and a half to learn the whole secret. Why I drew 'first blood' three weeks after I started, and landed this position last June, just four months later!—But, listen, if you're interested, I'll tell you all about it, what do you say to lunch on Thursday. Can you make it?"

I decided that I could and met him accordingly. Bob started bubbling over the minute we were seated.

A Luncheon Talk That Changed My Whole Life

In view of his own remarkable success, his enthusiasm was excusable. He told me how Charles Lederer, the famous artist and cartoonist, had drawn upon his thirty years of experience and constructed a home-study art course along lines never before attempted. Working on a new idea Mr. Lederer had condensed the whole field of commercial art into thirty fascinating lessons. He had boiled the whole system of training down to one great principle. And so simple was it, so logically arranged that anyone, whether he had had previous experience or not, could not fail to progress easily and rapidly.

Bob insisted that if I liked to draw at all, the very best thing I could do was to get this wonderful course and give it a trial. He pointed out that bookkeeping led to nowhere (I knew this). He told me about the amazing opportunities in commercial art. He told me about the hundreds of high salaried positions vacant for lack of trained men. He spoke of the wonderful fascination of the business, the short hours, the delight of creating—And, finally, he wound up with a

recommendation to start right away "knocking 'em dead."

I thought it all over. No doubt about it—I was dissatisfied.—And I had always wished that I could draw. My boyhood ambition had been to be a funny paper artist.

But it all seemed so impossible—artists were born, not made—and I couldn't draw. However, Bob had done it, and—well, I couldn't lose anything, and the long and the short of it was that I sent for Bob's course.

A Knock-Out Surprise

Of course, I was skeptical when I received the little package of which Bob had spoken so highly. But my "Doubting Thomas" attitude changed before I had spent an hour with it.

Bob had not exaggerated. I found the "One great secret" that he had talked about, and mastered it in just one hour and ten minutes by the clock. That same evening I sketched some little pictures—and they were good.

My delight and astonishment knew no bounds. Every evening I kept at it. Although I never put in more than a couple of hours a day, I soon found that drawing could be taught as easily as typewriting or shorthand work.

The fashion angle appealed to me the most. I specialized on that, and a month later I collected some of what I considered my best work, took a day off from the office and started to look for a job.

Bob gave me names of several firms, and a letter of introduction. The second place I called at hired me on the spot at \$45 a week! Think of it, and I was only a beginner!

Although I never put in more than a couple of hours a day, I soon found that drawing could be taught as easily as typewriting or shorthand work.

At Last—Real Money for Real Work

From that day on my progress has been steady and rapid. I am now head of the art department of one of the best known of the fashion magazines in the South. Every day, the one big rule that I learned in that first hour holds good. It is the basis of my entire success.

Through Mr. Lederer's amazing system, drawing can be taught as easily as anything else. And the best part of it all is, that the course teaches you to draw so that you can sell your pictures right from the start. That is really the most important part after all. Everyone wants to sell his work, and this is just what you can do with Mr. Lederer's great secret.

Don't misunderstand, I am not praising myself, The point is this—if I, who never was able to draw at all, could achieve this really remarkable success.



I developed an original style of my own

others can do the same, or better—and my salary is about \$10,000 a year.

But see for yourself—send for the course and try it out. If you can draw at all you will probably get along even faster than I. Remember, that opportunities in this uncrowded field are unlimited. There is a constantly growing demand for cartoonists and illustrators. Don't miss this wonderful opportunity to fit yourself in your spare time for the best paying and most fascinating profession in the world.

DAVID BEACH.

Five Days Free Trial

We want you to prove to your own satisfaction the tremendous value of Mr. Lederer's discovery. It will not cost you one penny. We want you to examine the Entire Course at our expense for five days. If you will just fill out the coupon below, detach it and mail it to us, we will gladly send you the complete course for your approval. We feel sure that when you see the surprising simplicity of this method you will agree with us that it is the greatest discovery ever made in this field.

Look it over, test it out—then if after five days you decide that you want it, send us \$5.00. If you do not wish to keep it, return it to us and forget the matter.

But act AT ONCE. Learn to draw—whether or not your aim is commercial art. It is a big asset no matter which field you are in. Let us disclose to you the whole secret. Detach the coupon and mail it TODAY. Independent Corporation, Dept. D-1105, 319 Sixth Avenue, New York.

FREE EXAMINATION COUPON

INDEPENDENT CORPORATION
Dept. D-1105, 319 Sixth Ave., New York

You may send me the Course or Courses checked below. Within five days after receipt I will either return them or send you \$5 for each in full payment.

- Drawing, Art Cartooning Course (\$5)
- Roth Memory Course (\$5)
- By Charles Lederer
- By David M. Roth
- How to Read Character at Sight (\$5)
- Mastery of Speech (\$5)
- By Dr. K.M.H. Blackford
- By Frederick Houk Law
- Super-Salesmanship (\$5)
- How to Write Stories (\$5)
- By a Newcomb
- By Prof. W.B. Pitkin
- Paragon Shorthand Course (\$5)
- By Alexander Lichtentag

Name.....

Address.....

The Third Edition of the Consolidated Radio Call Book Very Greatly Enlarged

192 pages. (32 pages more than 2nd edition,) better paper, stiff covers etc.

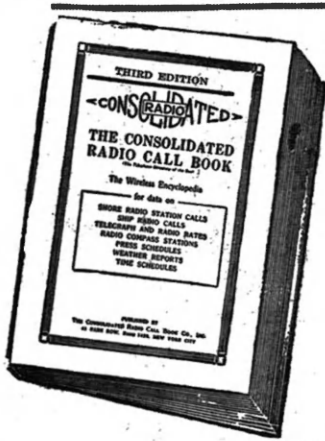

Some of the special information contained in the new book: Radio rate sheet (charges to and from vessels, etc.); Cable rates; Table for finding cable charges to various points; Weather reports and hydrographic reports of the world; Time signal section of the world; American radio compass stations; French radio compass stations; British radio compass stations; Canadian radio compass stations; General information section; International abbreviations; High power radio stations of the world; Press schedules of spark stations.

The Consolidated Radio Call Book is the only book in print officially listing all the Radio calls as issued by the Bureau of Commerce. Every vessel and land station in the world is represented and listed alphabetically, according to names of vessels or land stations, and according to call letters; Revision of American coastal stations under U. S. Naval control, and their new calls.

Every New Amateur Call Is Listed

SPECIAL—Given Free with Each Copy

A Wireless Map of the World in colors is given absolutely free with each copy. This map shows the locations of all the high powered RADIO stations in the world, including the time signal stations. In addition it tells at a glance how far away any of these stations are. Of greater interest are the time zones, which enable the amateur to compute instantly the correct time for the zone in which he is located from any time signal station.

The second edition of 10,000 copies was exhausted in ten days. The third edition is selling just as quickly. Don't wait until it is all gone. Order at once, either direct from us or from your favorite dealer.

Price \$1.50 Prepaid

Order Direct from us or for sale by the following responsible Dealers:

- | | | |
|--|---|--|
| American Electro Tech. Appliance Co.,
New York City | Linze Electrical Supply Co., St. Louis, Mo. | Radioelectric Shop,
Cleveland, Ohio |
| American Hardware Stores,
Boston, Conn | Manhattan Electric Supply Co.,
New York | Ray-Di-Co.,
Chicago, Ill. |
| Atlantic Radio Co.,
Bridgeport, Mass. | McCarthy Bros. & Ford,
Buffalo, N. Y. | Reuter Electric Co.,
Cincinnati, Ohio |
| Bamberger & Co., L.,
Newark, N. J. | McClurg & Co., A. C.,
Chicago, Ill. | Riverside Laboratory,
Milwaukee, Wis. |
| Benwood Specialty Co.,
St. Louis, Mo. | Meter Electrical Construction Co.,
Oshkosh, Wis. | Rose Radio Supply,
New Orleans, La. |
| Brode Electric Co.,
Los Angeles, Cal. | Meyberg Co., Leo J.,
San Francisco, Cal. | Saunders Co., Geo. S.,
Boston, Mass. |
| Bunnell & Co., J. H.,
New York City | Mohawk Electrical Supply Co.,
Syracuse, N. Y. | Schmidt & Co., Rudolph,
Rochester, N. Y. |
| California Electric Co.,
San Francisco, Cal. | New Era Shop,
Milwaukee, Wis. | Sears, Roebuck & Co.,
Chicago, Ill. |
| Catton, Neill & Co.,
Honolulu, T. H. | Newman-Stern Co.,
Cleveland, Ohio | Service Radio School,
Washington, D. C. |
| Central Radio Co.,
Independence, Mo. | Nola Radio Co.,
New Orleans, La. | Shaffers',
Norfolk, Va. |
| Chicago Radio Apparatus Co.,
Chicago, Ill. | Noll & Co., E. P.,
Philadelphia, Pa. | Shotton Radio Mfg. Co.,
Scranton, Pa. |
| Continental Radio & Electric Corp.,
New York City | Northwest Radio Service Co.,
Seattle, Wash. | Smith Bros.,
Sarnia, Ont., Canada |
| Cutting & Washington Radio Corp.,
New York City | N. S. W. Bookstall Co.,
Sydney, Australia | Smith Novotoy Electric, Inc.,
Charlotte, N. C. |
| Detroit Radio Laboratories,
Detroit, Mich. | Paramount Radio Supply Co.,
Atlantic City, N. J. | Southern Electrical Supply Co.,
San Diego, Cal. |
| Dewey Sporting Goods Co.,
Milwaukee, Wis. | Parks, Henry Francis,
Butte, Mont. | United Radio Telegraphers' Assoc.,
Baltimore, Md. |
| Doubleday-Hill Electric Co.,
Pittsburgh, Pa. | Pearlman's Book Shop,
Washington, D. C. | Western Radio Electric Co.,
Los Angeles, Cal. |
| Electro Importing Co.,
New York City | Penn Radio Apparatus Co.,
Reading, Pa. | Whitall Electric Co.,
Westerly, R. I. |
| Fadley Electric Co.,
Minneapolis, Minn. | Pennsylvania Marconi Wireless School,
Philadelphia, Pa. | White & Boyer Co.,
Washington, D. C. |
| Fuller Co., Seth W.,
Boston, Mass. | Philadelphia School of Wireless
Telegraphy,
Philadelphia, Pa. | White Co., The
Columbus, Ga. |
| Gurd & Co., Wm.,
London, Canada | Piedmont Electric Co.,
Asheville, N. C. | Williamson Electric Co., H. E.,
Seattle, Wash. |
| Hico Wireless Supply Co.,
Marion, Ill. | Pioneer Electric Co.,
St. Paul, Minn. | Wilmington Electrical Specialty Co.,
Wilmington, Del. |
| Holt Electric Utilities Co.,
Jacksonville, Fla. | Pitts Co., F. D.,
Boston, Mass. | Wireless Mfg. Co.,
Canton, Ohio |
| Jenkins, Lester I.,
New Bedford, Mass. | Post Office News Co.,
Chicago, Ill. | Wireless Press,
New York City |
| Katzenbach & Co., F. S.,
Trenton, N. J. | Precision Equipment Co.,
Cincinnati, Ohio | Young & McCombs,
Rock Island, Ill. |
| Kendall Co., W. D.,
Worcester, Mass. | Radio Distributing Co.,
Newark, N. J. | Young Men's Christian Assoc.,
Los Angeles, Cal. |
| Killoch Co., David,
New York City | Radio Electric Co.,
Pittsburgh, Pa. | Zamoiski Co., Jos. M.,
Baltimore, Md. |
| Kluge, Arno A.,
Los Angeles Cal. | Radio Equipment Co.,
Boston, Mass. | |
| Krause & Co. A. F.,
Detroit Mich. | | |
| Lehigh Radio Co.,
Bethlehem, Pa. | | |

Published by

Consolidated Radio Call Book Co., Inc.

41 Park Row, New York City

Learn Electricity

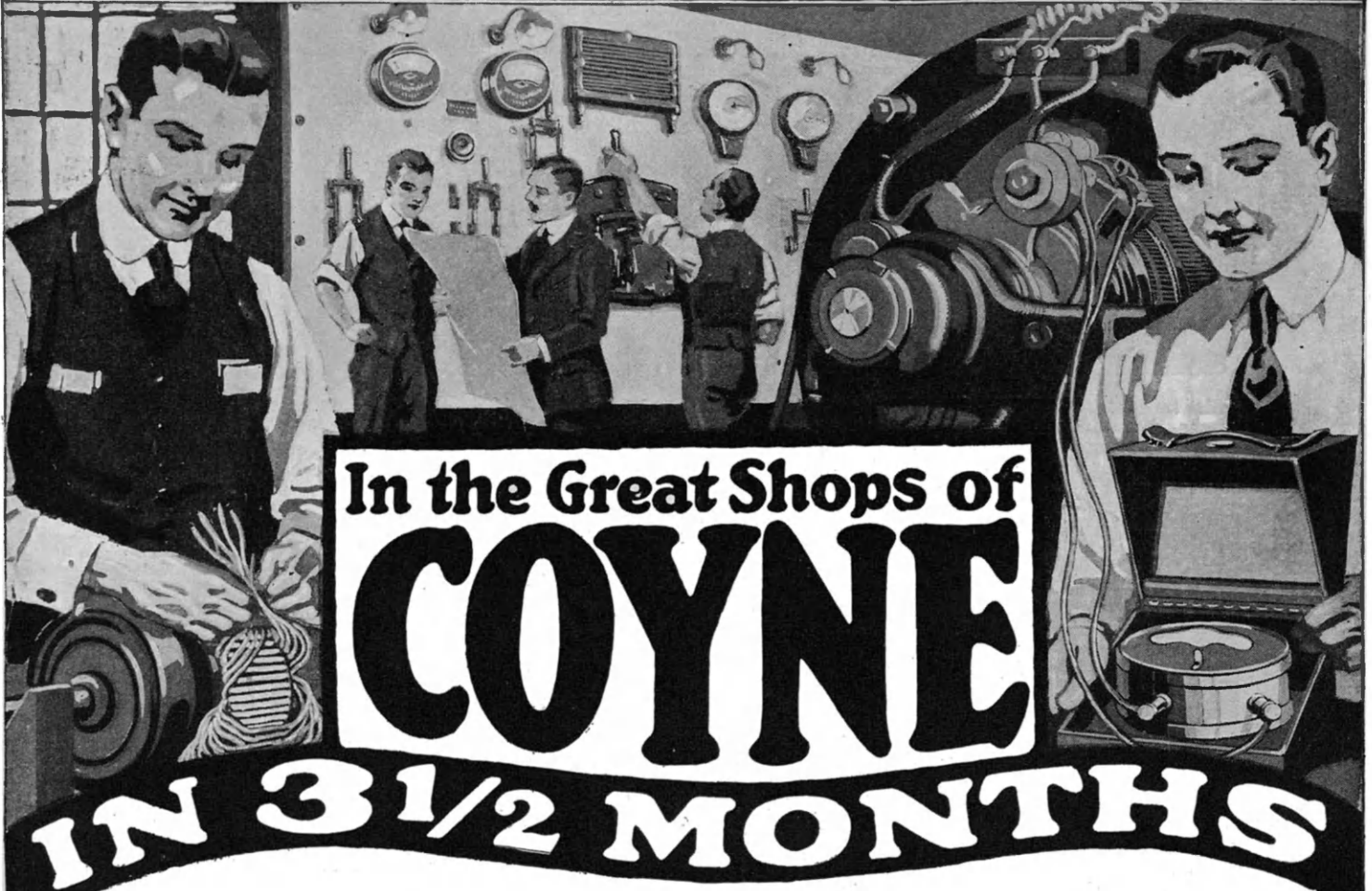

In the Great Shops of
COYNE

IN 3 1/2 MONTHS

Hundreds of our graduates are making big money as Power Plant Operators, Electrical Engineers, Telephone Men, Superintendents, Electro Auto Engineers, etc. Hundreds of others are in the electrical contracting business for themselves and making from \$3,000 to \$20,000 a year. I want you to drop your present line and come to Coyne now and let us prepare you for big opportunities. There is hardly any limit to what Coyne trained men earn. In less than four months you can become an electrical expert and hold down a big paying job. **MAIL COUPON NOW.**

Be an Expert in 3 1/2 Months

Our system assures your success in this study. In 98 days we have fitted thousands to make a smashing success. Now we want you to come—for the demand for practically trained men was NEVER so large. We beat the world at turning out PRACTICALLY TRAINED ELECTRICIANS in quick time at small cost. We'll fit you in 98 days (stay longer if you wish ABSOLUTELY FREE of charge) to do all kinds of electrical work—from the simplest bell mechanism to the mighty motor and Electric Locomotive—and turn you out an all-around man ready to accept a fine position in any branch of the electrical profession.

Earn While You Learn Day or Evening Courses

MAKE YOUR EXPENSES IN CHICAGO. Don't wait to save a lot of money. We have an employment manager whose sole business is to secure PART TIME jobs for students who need some extra help to meet their expenses. Hundreds of our students have worked their way through school and you can do the same. This is a most wonderful opportunity for you to secure the finest kind of Practical Electrical Training under circumstances that place it within the reach of any ambitious man. The cost of tuition is low and small easy payments are arranged if desired. All tools and equipment are furnished free.

Automotive Electricity FREE

We are able for a limited period to make you this astonishing offer—a course in Automotive Electrical Engineering—FREE. We have just greatly enlarged and newly equipped our Automotive Department with thousands of dollars worth of the latest apparatus, and can give the finest training in America on batteries, ignition, lighting and starting systems, as used on autos, trucks, tractors, etc. To those enrolling in our complete electrical course now, we offer you this entire automotive electricity course FREE. The cost of this training would cost you elsewhere more than we charge for our entire course. Act on this offer NOW. If we hear from you at once, we will reserve a course for you without charge.

MAIL COUPON—OR WRITE—FOR FREE CATALOG—RIGHT NOW

\$65 TO \$175 A WEEK

Your future lies in the Electrical Field. You like the work—it's a man game. Decide to enter now when the industry is growing faster than ever before and the demand for trained men vastly exceeds the supply—when BILLIONS are being invested in Electrical improvements and the certainty of your assured success is greater than ever before. You don't need much money. ACT NOW—send coupon for big free Catalog and prepare to come at once to Coyne—America's Greatest Electrical School, where you will be trained at least expense by the best and quickest method of instruction—the "Learn by Doing" system perfected by us in 21 years of success.

Big Job Open Now

Hundreds of big jobs are open now to men who can fill them—such as Electrical Engineer—Dynamo Tender—Power Plant Operator—Trouble Man—Switchboard Operator—Auto Electrician, etc. We will assist you to secure one of these jobs when your training is finished.

Simplest Instruction Known

You don't need to take one to four years to get your training. Neither do you need previous experience. For we use no books, have no classes and do not teach by correspondence. Electrical experts stand beside you to guide and instruct you while you do the actual work with your own hands, just exactly as you will later do it when you graduate with your diploma as Master Electrician. You are started at the beginning of things and the whole fascinating field of electricity is laid open before your eyes. Nothing can stump a Coyne trained man after he gets his diploma.

SEND FOR OUR BIG FREE BOOK.

Fill out the coupon and mail it to me personally NOW. Get the big book that tells what Coyne graduates have done—and what you are most interested in and mail it NOW.

**BENNETT W. COOKE, President,
Coyne Trade and Engineering Schools,
Dept. 25, 39-51 East Illinois St.,
Chicago.**

**B. W. Cooke,
President,
Coyne Trade
& Engineering
Schools, Dept. 25,
39-51 E. Illinois St.,
Chicago, Ill.**

**MAIL COUPON
FOR FREE
BOOK
NOW**

Dear Sir: Send now—free—postpaid and without obligation to me—your big catalog—reservation offer of a free course in Automotive Electrical Engineering, and full details.

Name

Street (R.R.).....

CityState

SPECIAL PREMIUM OFFER

With a Year's Subscription to "Science and Invention" Formerly (Electrical Experimenter) or "Radio News"

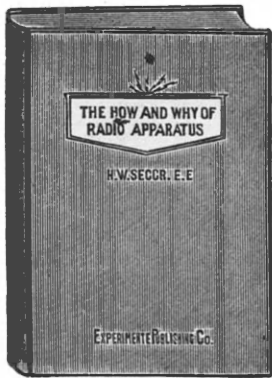

This newest of Radio works, bound in flexible velum and hand sewed, has 160 pages. Size of book 6 x 9 inches.

Offer A REG. PRICE
 "Science and Invention" \$3.00
 for one (1) year with
 The How and Why of Radio Apparatus \$1.75
\$4.75

Offer C
 "Science and Invention" for one (1) year with A Thousand and One Formulas

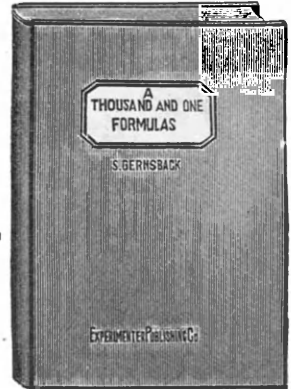

A Laboratory Handbook for the Experimenter. Bound in flexible velum. 160 pages. Size 6 x 9 inches.

SPECIAL PRICE OFFER, A or C, \$3.75

Offer B REG. PRICE
 "Radio News" \$2.00
 for one (1) year with The How and Why of Radio Apparatus \$1.75
\$3.75

Offer D
 "Radio News" for one (1) year with A Thousand and One Formulas

SPECIAL PRICE OFFER, B or D, \$2.75

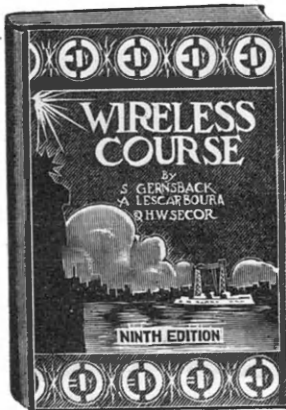

Book is bound in flexible velum; has 160 pages. Size 7 x 12 inches.

Offer E REG. PRICE
 "Science and Invention" \$3.00
 for one (1) year with Wireless Course in 20 Lessons \$1.25
\$4.25

Offer G
 "Science and Invention" for one (1) year with Experimental Electricity Course

SPECIAL PRICE OFFER, E or G, \$3.50

Offer F REG. PRICE
 "Radio News" \$2.00
 for one (1) year with Wireless Course in 20 Lessons \$1.25
\$3.25

Offer H
 "Radio News" for one (1) year with Experimental Electricity Course

SPECIAL PRICE OFFER, F or H, \$2.50

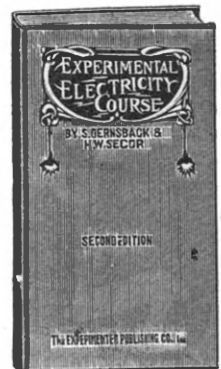

Book is bound in flexible velum; has 160 pp. Size 5x9 in.



Printed on heavy paper, paper bound. Size 5 x 7 inches. Fully illustrated. The latest book out.



Book has 100 pages. Size 5 x 7 inches. 88 illustrations. Paper cover printed in two colors.

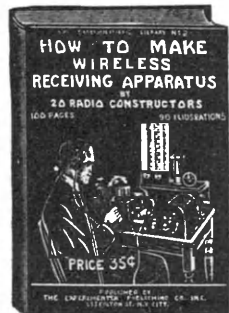

Book has 100 pages. Size 5 x 7 inches. 90 illustrations. Paper bound, in two colors.

Offer K Reg. Price
 "Science and Invention" \$3.00
 for one (1) year with Design and Construction of Audion Amplifying-Transformers. How to Make Wireless Sending Apparatus. How to Make Wireless Receiving Apparatus. **Special Price \$3.25**
 .95
\$3.95

Offer L
 "Radio News" \$2.00
 for one (1) year with Same Books as offer (K) **\$2.25**
 .95
\$2.95

Bound Volume No. VII of ELECTRICAL EXPERIMENTER Price \$2.00

This volume comprises the issues of May, 1919, to April, 1920, inclusive. Over 1,300 pages, 2,400 illustrations, and countless articles, diagrams and formulas. It is a complete cyclopedia of scientific development written in non-technical language. It contains interesting and valuable ideas for many months to come. Attractively bound, stamped in gold. A welcome addition to your library. *Send for your copy today.*

EXPERIMENTER PUBLISHING COMPANY, Inc.
 236 Fulton Street, New York City, N. Y.

Gentlemen:
 I accept your offer..... Enclosed find \$.....
 in payment of premium and one year subscription.
 Name.....
 Address.....
 Town..... State.....

Here's YOUR CHANCE!



"THEY PUT ME IN THE BIG PAY CLASS"



Why Don't You Earn **BIG MONEY?**

Big jobs are just waiting for men like you to fill them. The automobile game has grown so rapidly that there's an opening everywhere for a fellow qualified to hold a worthwhile job. No schooling or apprenticeship needed—if you will only realize that **now is the time** for you to get into this big-pay game. You, like thousands of other fellows, will soon be enjoying a real job thru the help of these great automobile engineering books.

FREE Examination!

The very latest, up-to-date six volume library—by fifteen of America's greatest auto experts—containing absolutely everything anyone needs to know about the upkeep, care and repair of motor vehicles and tractors. Written in plain, forceful English that anyone can understand—over 2600 pages, 2300 pictures, diagrams and blueprints, bound in flexible American Morocco, gold stamped. Your set will be shipped immediately for **7 days' free trial** if you send us the coupon today.

Send No Money

You don't have to spend a penny in advance to examine these valuable books in your home or shop. Just fill in the coupon, pay the small express charge when the books arrive—and they are yours for seven whole days to study as you want!

Bargain Price for You!

We are letting you share in our good fortune! The price on these big-pay books is reduced from \$45.00 to \$24.80—over 75,000 sets have been sold to date! That means our manufacturing cost has been lowered by big production—and you get the benefit!

Only a Dime a Day!

If you decide that these books will really fit you for a big job, send us \$2.80, and then only \$3.00 a month until our special bargain price of \$24.80 is paid. Don't stand in your own path to bigger things. Fill in and mail the coupon now!

AMERICAN TECHNICAL SOCIETY

Dept. A-255, Chicago, U. S. A.

Partial List of Contents:

- Automobile Motors
- Welding
- Motor Construction and Repair
- Carburetors and Settings
- Valves, Cooling
- Lubrication
- Fly Wheels
- Clutch
- Transmission
- Final Drive
- Steering Frames
- Tires
- Vulcanizing
- Ignition
- Starting and Lighting Systems
- Shop Kinks
- Commercial Garage Design and Equipment
- Electrics
- Storage Batteries
- Care and Repair of Motorcycles
- Commercial Trucks
- Gas Tractors

128 Blueprints of Electric Wiring Diagrams

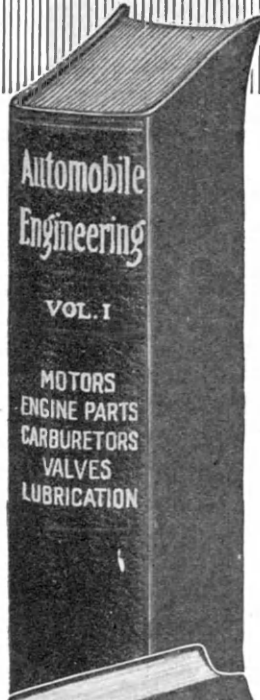

Along with every set goes a year's Consulting Membership in the American Technical Society (regular price \$12). Consult our experts without charge.

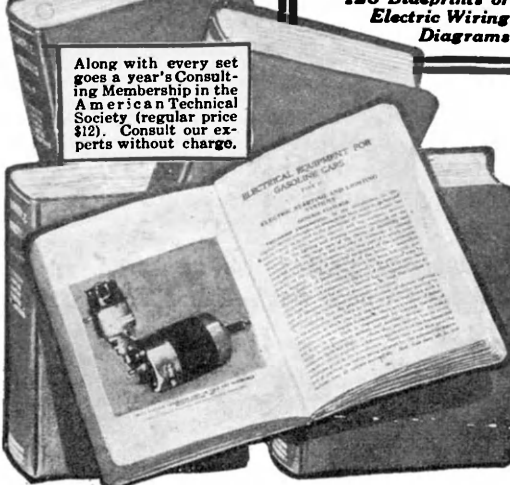

AMERICAN TECHNICAL SOCIETY
Dept. A 255, Chicago, U. S. A.

Please send me set of Automobile Engineering for 7 days' examination, shipping charges collect. I will examine the books thoroughly and, if satisfied, will send \$2.80 within 7 days and \$3.00 each month until I have paid the special price of \$24.80. If I decide not to keep the books, I will return them by express at your expense.

Name.....

Address.....

Reference.....

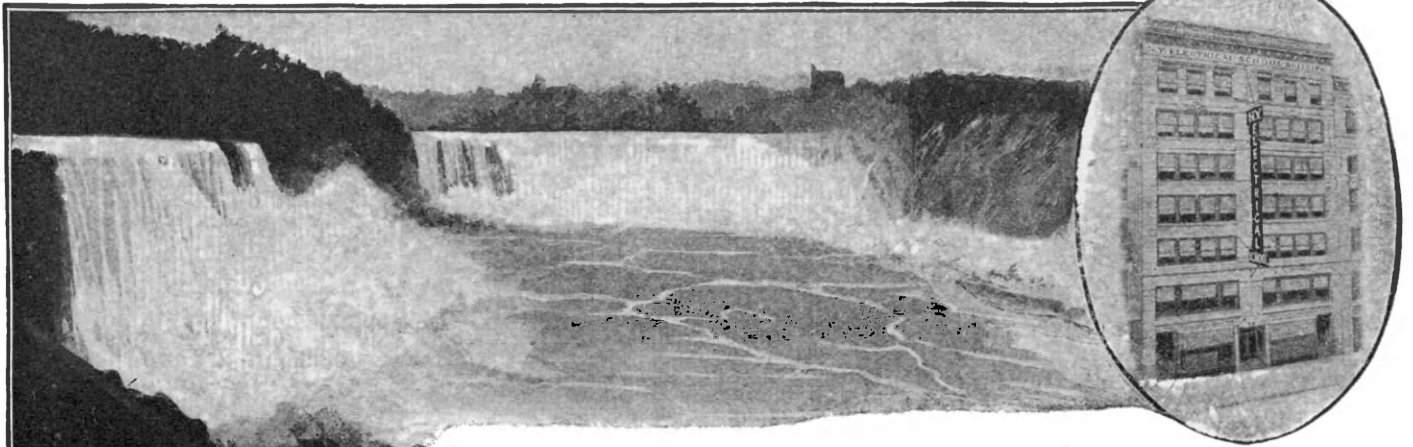

Master Electricity By Actual Practice

The only way you can become an expert is by doing the very work under competent instructors, which you will be called upon to do later on. In other words, *learn by doing*. That is the method of the New York Electrical School.

Five minutes of actual practice properly directed is worth more to a man than years and years of book study. Indeed, Actual Practice is the only training of value, and graduates of New York Electrical School have proved themselves to be the only men that are fully qualified to satisfy EVERY demand of the Electrical Profession.

The Only Institution of the Kind in America

At this "Learn by Doing" School a man acquires the art of Electrical Drafting; the best business methods and experience in Electrical Contracting, together with the skill to install, operate and maintain all systems for producing, transmitting and using electricity. A school for Old and Young. Individual instruction.

Over 6,500 Graduates are Successful Men in the Electrical World

No previous knowledge of electricity, mechanics or mathematics is necessary to take this electrical course. You can begin the course now and by steady application prepare yourself in a short time. You will be taught by practical electrical experts with actual apparatus, under actual conditions.

The N. Y. E. S. gives a special Automobile Ignition Course as an advanced training for Auto Mechanics, Garage Men and Car Owners. The course covers completely all Systems of Ignition, Starters, Lighting and other electrical equipment on automobiles, motor boats, airplanes, etc.

Let us explain our complete courses to you in person. If you can't call, send now for 64-page book—it's FREE to you.

New York Electrical School

29 West 17th Street, New York

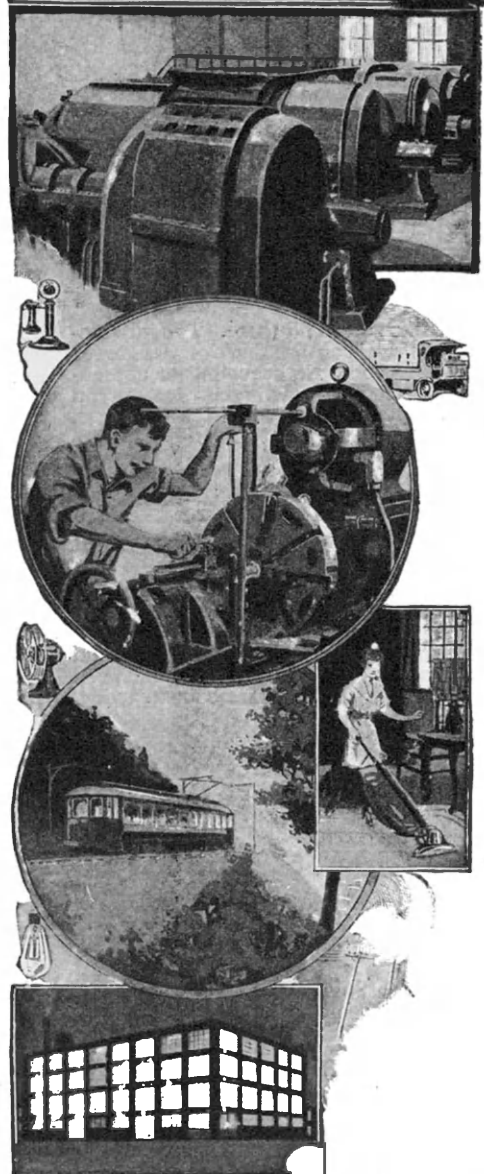

New York Electrical School
29 W. 17th St., New York, N. Y.

Please send FREE and without obligation to me your 64-page book.

..... NAME
 STREET
 CITY STATE

H. GERNSBACK, - EDITOR
H. WINFIELD SECOR, - ASSOCIATE EDITOR
T. O'CONOR SLOANE, Ph. D., - ASSOCIATE EDITOR

Double and Triple-Decking Busy City Thorofares

IN the city of New York, Dr. John A. Harriss of the Board of Police Commissioners was given a banquet in honor of the first anniversary of the installation of the Fifth Avenue transit signal towers. These were constructed and maintained by Dr. Harriss at his own expense and have done more to

embody further suggestions on the part of this magazine.

Sixth Avenue now possesses an elevated railroad. On the level of this Dr. Harriss proposes to erect a second story street, the sidewalks of which will give access to a second row of stores on the avenue on the level of and entered from the new

by escalators. In this development Sixth Avenue will acquire two additional stories of sidewalks, and will contain three stories of high rental stores and shops, two stories of roadway for automobiles and vehicles, two stories for electrically propelled cars. In its many immense office buildings New York has changed



© 1921 by Science and Invention

The Idea of Building Double Streets and Triple-Decked Sidewalks Along Busy Thorofares Has Been Advanced for Adoption in Such Large Congested Cities as New York. The Illustration Above Shows How the Elevated Railroad Along Sixth Avenue in New York City Would Appear with These Improvements.

help the solution of the traffic problem on Fifth Avenue than anything which has ever been tried. The Doctor now proposes to bridge over Sixth Avenue with a second story so as to make it a two story street and our cut not only gives the idea formulated by Dr. Harriss, but

sidewalks. In order to prevent the darkening of the street they will be made of translucent glass. In our illustration we show a third sidewalk, this time of quite narrow width, which will bring into play a third series of stores and access to which from the Harriss sidewalk will be

from a city of four story buildings to one of twenty to thirty story buildings. The enormous number of occupants of these buildings require extra sidewalk room more imperatively even than automobiles and vehicles require the extra deck proposed by Dr. Harriss.

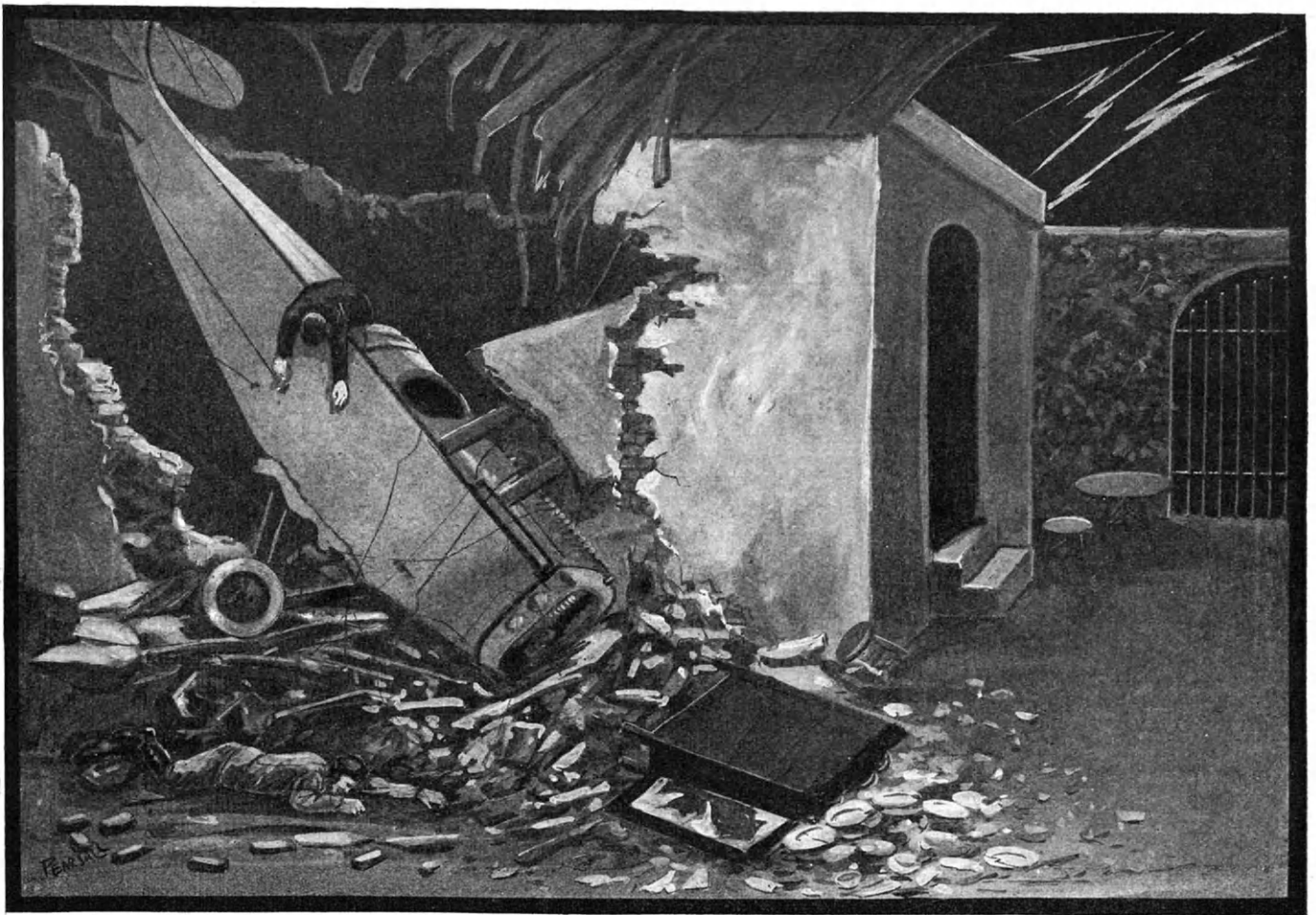

© 1921 by Science and Invention

The Rather Novel Effect As Seen in the Play "The Broken Wing," Now at the 48th St. Theatre in New York City. The Ponderous Curtiss Airplane Seemingly Drops Thru the Roof of the Cottage on the Stage at the Latter Part of the First Act and Catapults the Mechanic on to the Stage, While Bricks and Mortar Loosened by the Crash, Fall All Around and Upon Him. Thus the Pilot Enters Rather Informally Upon the Residence of Her, Who Is to Be His Bride. The Action Is Described Below.

Science In Stageland

By H. WINFIELD SECOR

FALLING AIRPLANE IN "THE BROKEN WING"

A PLAY which has not only a wondrous heart appeal but has come to the front because of a very spectacular scene, is "The Broken Wing," now playing at the "48th St. Theatre." The principal scene in this play is produced by the crashing airplane. This airplane smashes thru the roof of an adobe house or at least apparently so, at the end of the very first act.

In viewing the scene of action, one sees the Mexican homestead with the girl and foster father conversing on various subjects.

A storm arises and the stage becomes darkened, while vivid lightning illuminates the background and the interior of the home. Suddenly the purr of an airplane engine is heard in the distance; it becomes louder. The girl and her father rush from the room to see what the commotion is about. There is a crash! The bricks of the building topple down. The lifeless form of the observer is seen to catapult from the airplane as it crashes down thru the roof. Lightning flashes again illuminate the scene to show the body of a pilot hanging unconscious from the fuselage of the airplane, while the body of his "Buddy" lies lifeless beneath the load of bricks and mortar.

The second scene shows the aviator with the machine which has crashed down thru the scenery, the airplane being a genuine Curtiss in perfect condition (except for the battering it receives at every performance),

Explaining the Famous Naval Battle Scene from "In the Night Watch"

which with but slight repairs may be flown.

The airplane crash is more or less of a psychological development in that the airplane does not in reality crash to the stage floor, but is already in that position cleverly concealed by the stage scenery. During the storm the stage is only illuminated intermittently by vivid flashes of lightning and the lull between these flashes lasting about one or two seconds, presents ample time for the introduction of the crash.

Overhead a canvas sheet filled with plaster is suddenly releast, while a cover hiding a falling brick wall is drawn back and the bricks automatically dislodged, fall to the stage floor. A china closet is overturned, as is a bookcase, and the broken dishes intermingle with the books and scatter themselves all over the place. Flashes of lightning again illuminates the scene. Dust and plaster fall on the objects and the room can hardly be discerned. Several successive flashes of lightning now enable the audience to see the catapulting body of the observer hurtle thru the air and land on the stage some of the bricks falling upon him.

The rumbling of the airplane engine is executed by four riveting hammers con-

nected in parallel and which turn out upon a steel plate the merry "rat-tat-tat" of a 300 H. P. 12-cylinder Liberty engine. A healthy load of bricks, cobble stones, and scrap iron suspended about 25 feet above the stage floor, assists in making the crash appear to be of ponderous proportions. These stones and scrap iron are suspended in a cradle which is releast by a stage-hand at the opportune moment and the crash which occurs when they hit the steel plate placed upon the stage floor in back of the scene, reverberates thru the building.

WONDERFUL NAVAL BATTLE FROM "IN THE NIGHT WATCH"

WITHOUT a doubt the most pretentious and realistic naval battle ever staged in the theater is that appearing in the New York Century Theatre success, "In the Night Watch." An all-star cast presents this famous play which has been adapted from the French drama "La Veille d'Armes." The dramatis personae include Mr. Robert Warwick as *Capt. de Corlaix* and Miss Jeanne Eagles as his wife, *Eugenie de Corlaix*.

This play marks an epoch in American theatrical productions not only for the excellence of its cast, but particularly for the massive, true-to-life stage scene showing the French cruiser *Alma*, going into battle with a German warship on the high seas.

The second act brings us to the great

(Continued on page 62)

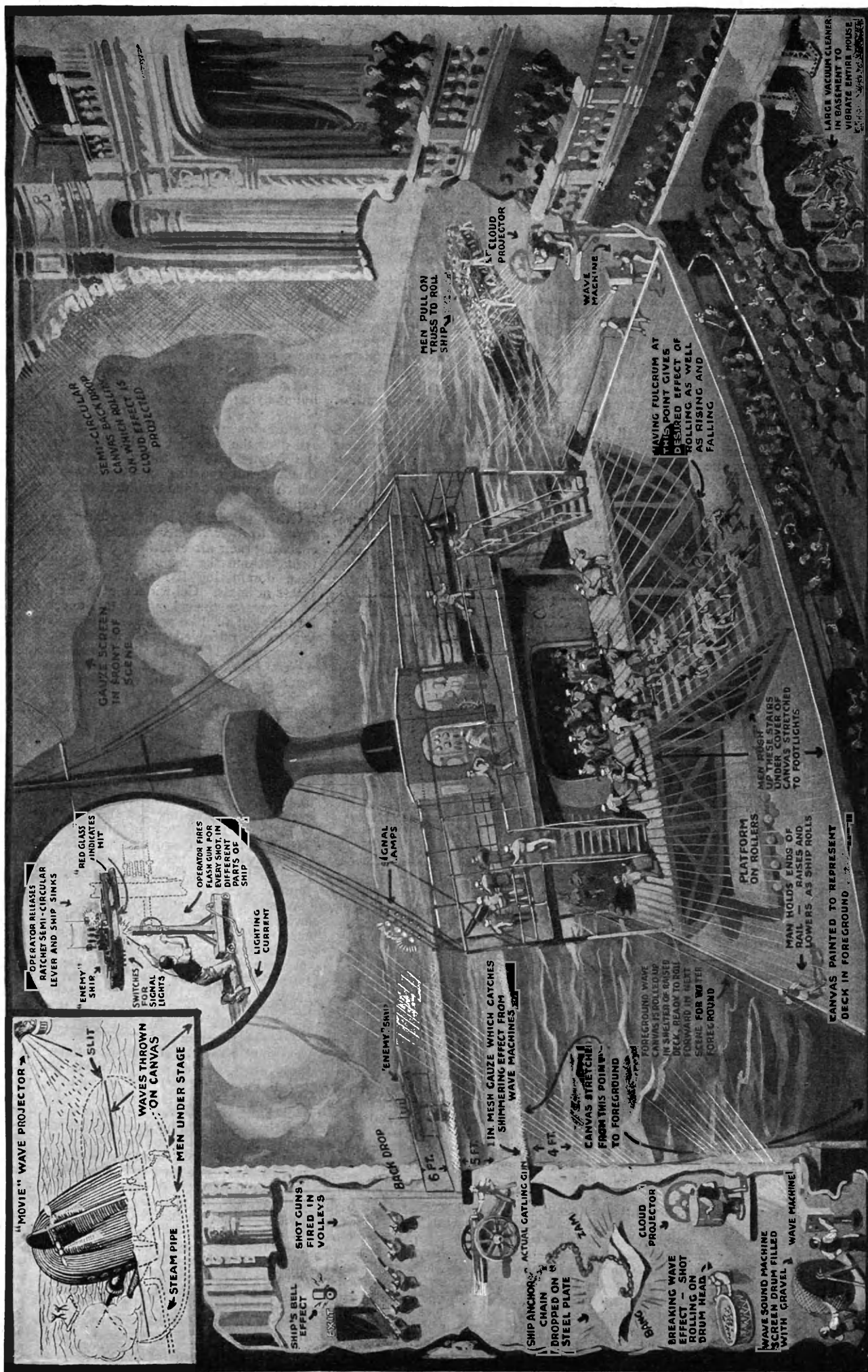

© 1921 by Science & Invention

And Here We Have the Most Spectacular Play in New York, "In The Night Watch." There Are So Many Things Occurring at the Same Time in the Action of This Scene, That Even the Lengthy Description in the Accompanying Article Cannot Do It Justice. The Waves Are Heard to Swish As the Vessel Plows Thru the Turbulent Waters and the Break of Each Wave Can Likewise Be Distinguished. Anchor Chains, Gatling Guns, Shot Gun Vacuum Cleaners, Motion Picture Waves and Cloud Rollers All Assist in Making the "Battle Scene" Spectacular and Realistic, and Then This Ship Sinks the After End or Stern Can Be Seen Disappearing Beneath the Motion Picture Waves, While Steam Arises and the Boilers Explode.

Monsters of Long Ago

By Dr. E. BADE

THAT which was born, lived, endured, and loved in the prehistoric days, that which died and passed away in those distant epochs which gleam thru a misty veil to the present day from incomprehensible distances have become known thru nature's prints and petrifications more or less well preserved. In a book with thick pages nature has pictured the story of our earth in the strata of its crust. In those distant prehistoric ages the waves of the ocean passed over places which are continents today, where mountains lift their snow-covered peaks, and inland lakes twinkle like clear blue eyes.

A shoreless ocean covered the earth in prehistoric times. Octopi, sharks, crabs, and armored fish inhabited the lukewarm waters while algæ and seaweeds formed thick masses, letting the feathered or leafy forms follow, in rhythmic play, the water's movements. With the passing of time, low lying islands appeared above the level of this primeval sea; with the ebb they lay dry, but the flood tides rolled over them, as if the waters would bring back into the sea that which had risen from out its bosom.

The atmosphere was charged with carbon dioxide and thickly laden with moisture. Mosses and ferns timidly took possession of the newly created land that had come forth only a little above the primeval sea. The land bodies became, through the gradual rising of the land, larger and larger. The flat islands joined together and became a whole continent with their coasts, however, now and then becoming overflowed by the devouring sea, but rising again and again in the changing play of the battle of elements.

Just as the plants seemed to migrate from the water to the land, so did the animals also. The gill breathers, living in the low swampy lagoons, began to breathe in the heavy atmosphere. This transformation which was slow to develop, presented the first tailed amphibians whose skeleton clearly showed their relation to fish ancestry. Their relations, being more developed, took their place. These were the ancestors of the small reptiles living well into the Tertiary period. They lived on the shore; it seemed as if they could not part from the water.

Nevertheless there were land as well as swamp inhabiting animals that always returned to a more or less aquatic life; as the duckbill saurians, which turned into lung breathing sea animals plundering the mussel banks of the Trias seas.

The land formations of the Jurassic period became populated with reptile life which soon adapted itself to all existing conditions. Slowly the saurians rose higher and higher in their development until they became the mighty rulers of the universe. As their associates, altho there were great and giant forms, there also grew up the small and smallest varieties of saurians. The amphibians that still lived at that period, were few in number and inhabited the lowlands here and there, undisturbed by the carnivorous saurians. The saurians attained the height of their development after the actual saurian period, just as the first mammals appeared on the earth.

The land saurians, the dinosaurs, developed into unbelievable proportions

reaching massive and gigantic forms. The majority of them were harmless, plump, plant eating mountains of flesh, with small heads and tiny brains, protected from their enemies, the carnivorous saurians, by their size alone. In addition they had an effective protective medium in their whip-formed tails with which mighty blows could be dealt.

The first discoveries of giant dinosaurian bones were made in the United States, in the Rocky Mountains, where the skeletons of the Diplodocus were first brought to light. Larger species existed in Africa where a big bed of remains were uncovered. These animals probably lived in small herds or families and spent their time on the shores of waters and swamps.

The earlier types of saurians walked on all fours just as well as on the hind legs. The later varieties walked directly on their hind legs and used the forelegs for grasping and holding their food. Others used them as weapons as for example the Iguanodon, a plant eater, a monster which attained the height of 24 feet. The forepaws of Crenosaurus (Alosaurus), a 14-foot high meat-eater, were very small. This creature propelled itself on its hind legs by hops and bounds not unlike the

OUR NINTH YEAR.

WITH this issue SCIENCE AND INVENTION begins its ninth year. We desire on this occasion to thank our readers for their continued patronage, and we hope to still further improve the magazine during the coming year. Due to the tremendous costs, it was impossible last year to enlarge the magazine, but now that prices are falling we probably will be in a position soon to add more pages to the magazine, which we hope to do before the year is over.

May we have an expression from you if the magazine now meets with your full approval? We want honest criticism, as only in this case will we be able to improve the magazine continuously.—
Editor.

present-day kangaroo. Specialized forms of the carnivorous saurians moved about by springing, as Ornitholestes; the older varieties strode about with long strides, evidence of which we have in the well preserved foot prints made in the swamps and sands.

The habit of walking on the hind legs assisted the carnivorous saurians in discovering their prey in that it elevated their heads to such an altitude that it gave them a wide expanse of view. The smaller varieties of the stately plant-eating saurians were protected from the carnivorous saurians by a coating of armor. Triceratops was also armored and had in addition a strong spiked collar, and three horns upon its head, the largest of which was situated upon the bridge of the nose, with another smaller one over each eye. Naosaurus, a very old saurian (much older in fact than the Diplodocus or the Gigantosaurus), was armored with a high comb of hardened skin which was situated upon its back and held erect by projections of the spinal column. Stegosaurus was protected on neck and back with solid plates of armor, the projecting flaps being held erect while the tail was covered with spikes.

Among those saurians inhabiting the land, a few lived in the trees, developing their skin folds into batlike extensions

which enabled them to glide to the ground. These saurians gradually developed into animals of flight. The skin which the Pterodactylus used for flight was connected with the fifth finger which grew to gigantic proportions and was often as long as the whole body. In the beginning of their development these flying saurians included the smaller varieties which probably climbed trees in search of food. The mighty Pteranodon, an inhabitant of the Cretaceous period, had a wing span exceeding seven yards, being more than twice the spread of today's greatest flying bird, the condor. The entire structure of these giant saurians was built more for lightness than for bodily strength. This giant living flying machine did not, in all probability, weigh more than 37 pounds. The Pteranodon spent his life flying to and fro over the sea, just as the albatross and the frigate bird do today. Night found this saurian roosting on the lonely cliffs which rose out of the turbulent and threatening seas.

Other saurians, as the Tylosaurus, returned to their former aquatic life without changing their air-breathing organs. These then became the frightful tyrants of the deep dominating the smaller defenseless water animals. Coincident with their life in the water their leg and tail developed into typical fishlike appurtenances. These gradually unfolded into a finlike skin formation. The most numerous of the water saurians was the Ichtyosaurus, some specimens of which reached the extraordinary length of 30 feet. Their bodies were torpedo shaped, their heads terminating in a long pointed snout containing hundreds of pyramidally shaped teeth. This extraordinary animal glided thru the water with the speed of lightning. Ichtyosaurus became so habituated to the water that it did not seek the land even in the breeding season, the young being born in the water fully developed. This fact has been proven by the fossilized remains of the Ichtyosaurus in which the fossilized remains of their young were found.

Another inhabitant of the sea was the swan—or longnecked saurian, Plesiosaurus, which was probably the ancestor of the fish eater. The earliest varieties of the longnecked saurians lived in the Jurassic period and were not more than a few yards in length. But towards the end of their existence they were more than 54 feet in length.

Despite the fact that we only hear of the giant saurians in the Tertiary age, there were smaller varieties of each kind. When the saurians reached gigantic proportions, it was a sure sign of the approaching end of their existence. After developing to the highest possible attainments they passed out of existence. These saurians, the individual as well as the species, were not long lived; the stronger the degree of their development, after attaining the height thereof, the more quickly followed their extinction. As the number and variety of saurians cannot be stated with any degree of accuracy so also it is not possible to state that the senility of the saurians was the cause of their inability to develop new forms in the Cretaceous period in which they ceased to exist. There must have been far better reasons for their disappearance. The first

(Continued from page 60)



Allosaurus (Jurassic) About 14 Feet High.



Upper Arm Bone of the Gigantosaurus Africanus.



Gigantosaurus Africanus (Jurassic) About 100 Feet Long.

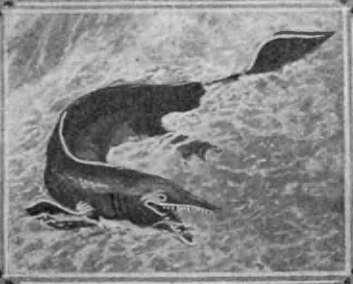

The Giant Tylosaurus Dyspelor. (Jurassic) About 70 Feet Long.



Trachodon (Jurassic) About 10 Feet High.

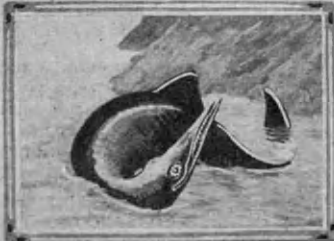

Ichtyosaurus (Jurassic) About 30 Feet Long.

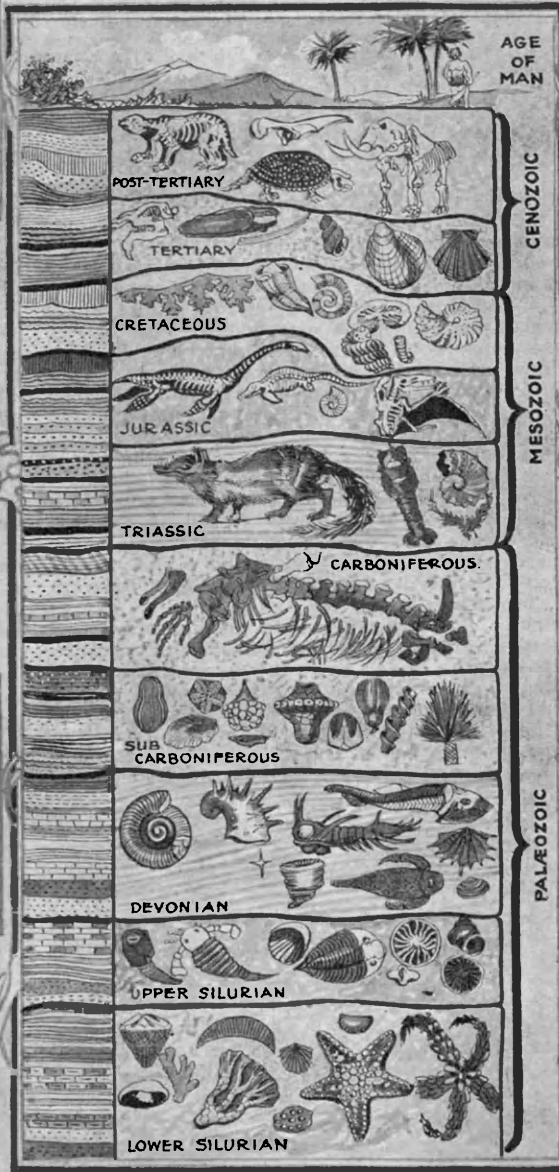

Stegosaurus (Jurassic) About 18 Feet Long.



Naosaurus (Jurassic) About 6 Feet Long.



Triceratops (Jurassic) About 30 Feet Long.



Iguanodon (Jurassic) About 24 Feet High.



Plesiosaurus. (Jurassic) About 54 Feet Long.



Pterodactylus (Jurassic) About 10 Feet Long.

Center Diagram Illustrates the Succession of Periods and Their Strata in the Earth's Crust and the Geological Names with Typical Remains of Animal Life By Which the Periods Are Identified.

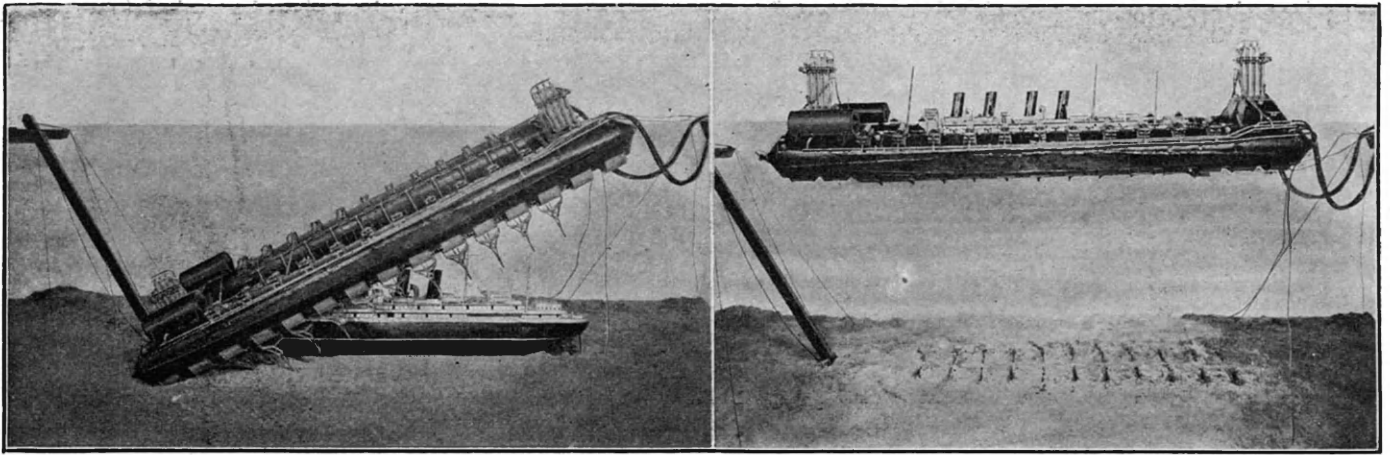

The Above Scene Shows the "Twin Submersible Salvager," Hovering Over a Vessel. Projecting Arms Bury Themselves in the Bottom and Lock Beneath the Vessel. A Guide-Column Member Steers the Salvager to the Proper Position.

The Salvager Having Come to Position Is Controlled From the Surface. The Arms Lock the Vessel to the Tank-Like Structure, and Into Which Air Is Pumped; the Ship Comes to the Surface by Flotative Effect.

To Raise Sunken Ships In 24 Hours

A BOSTON Engineer, John A. de Vito, claims to have solved the problem of recovering all manner of ships sunk in deep water. In proof of his claims, he has installed in Boston an 18 foot tank in which he gives, in detail, an interesting and practical demonstration of the raising of submerged vessels by means of his invention. The inventor claims that a full size *Twin Submersible Salvager*, as he calls his device, will raise wooden, concrete, or steel vessels of all tonnages within 24 hours after the wreck has been located.

First, a long tube-like affair, which is called a guiding column, is flexibly attached or pivoted between the catamaran bows of the securely kedged surface barge or lighter. The free end of this pivoted column, containing a trust iron shoe, also pivoted, is now allowed to submerge and imbed itself in the bottom at the bow of the sunken vessel. A sliding key, operating in a slotted track running the length of the column, accurately guides the bow of the Twin Submersible. Salvager in its descent to the wreck, regardless of tides, sea-way, cross-currents, and undertows.

The salvaging device consists of two large steel cylinders or pontoons, maintained parallel with one another. They are connected at either end, and are hinged laterally at the center of their connecting arches, so as to open and shut like a gigantic pincers. This arrangement enables the pontoons to laterally approach each other and to recede from each other by power devices, as the engineers require.

Like a clamshell dredge on a gigantic scale the Twin Submersible Salvager opens and submerges, bow first. After the bow of the submersible, guided and held in leash by the guiding column, has settled down over the bow of the sunken vessel, the stern is then also sunk. While submerging, the stern is held in position by cables running from kedge anchors to controls on the stern surface barge.

Powerful triple hydraulic plungers; placed vertically at the bow and stern of the apparatus, drive a series of trust steel supporting arms at an angle thru the silt, V-fashion, so as to penetrate beneath the vessel's bottom, their angle changing during the process of the closing of the apparatus. These supporting arms are flexibly attached on the

inner side of the bottom of each pontoon. Their inner ends are drawn upward by cables, hydraulically operated, until each lift or arm registers exactly with the contour of the vessel's bottom. In this way, by making each supporting arm lift a proportionate weight of the wreck, the vessel is safe-guarded from injury while being brought to the surface.

As the Submersible goes down bow first and comes up stern first, it has a lateral and longitudinal stability that make it positively non-capsizable. The inventor claims that it is designed on scientific principles, is free from doubtful arrangements, is seaworthy and reliable. Ships lost years ago and partly buried in the sand or silt offer no impediment to their being raised. All operations are conducted from the surface, and divers, when used, will be employed for observational purposes only. The device is patented in all Maritime countries.

How the Salvager Raises Ships

The accompanying photographs and diagrams show clearly the appearance and manipulation followed in applying the de

(Continued on page 56)

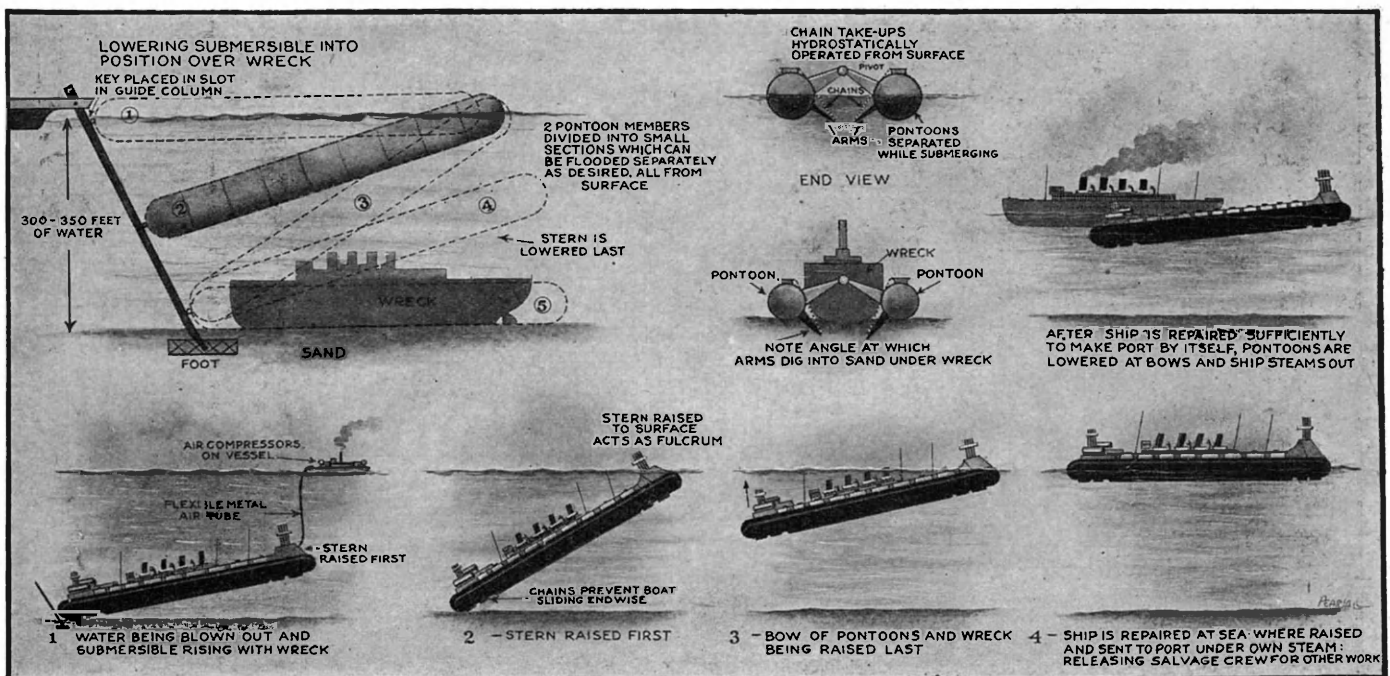

Doctor Hackensaw's Secrets

By CLEMENT FEZANDI



"..... The Doctor Went to a Covered Cage and Drew Therefrom a Most Curious Creature—Half-Cat, Half-Dog....."

©—1921—By Science & Invention

NO. 1. THE SECRET OF ARTIFICIAL REPRODUCTION.

(Author's Note. This first sketch is scarcely a story. It is merely a statement of what we shall see accomplished in the course of a very few years. Scientists now are able to fertilise the ova of the lower animals and raise the embryos to maturity in glass jars. We shall undoubtedly soon be able to do the same for the higher animals.)

"IS this Doctor Cuttenback?"
"Not quite,—I am Doctor Hackensaw."

"Well, you're the man I want, I reckon. My name is Silas Rockett, and I'm a reporter for The New York Morning Growl. Our editor learned that you have just made an important scientific discovery and I was sent to interview you."

"I'm very glad to see you, Mr. Rockett, for although my experiments are not yet completed, I have met with sufficient success to justify me in claiming to have made one of the greatest discoveries of the century, a discovery that from a financial point alone will bring in enough wealth to pay off the entire cost of the late World War."

"Is it possible? Why, from what I heard, all that you had discovered was the secret of artificial reproduction."

"Yes, Mr. Rockett, but it is evident you do not realize the value of the discovery. Let me first show you my methods, and I shall afterwards explain to you what a fortune they represent."

The doctor led the way to a series of test-tubes ranged in order in one corner of the room, and pointed proudly to them.

"There, Mr. Rockett," said he, "are my billions!" The reporter's face fell as he cast a disappointed glance at the insignificant row of test tubes of different sizes.

New York Tribune

First to Last—the Truth: News—
torials—Advertisements
Member of the Audit Bureau of Circulations.

TUESDAY, MARCH 15, 1921

Heart Beats For 8 Years In Glass Jar

Vital Organ of Chicken That Never Lived Thriving at Rockefeller Institute Under Carrel's Care

Long before the World War Dr. Carrel startled scientists with the announcement that he had kept portions of animals' hearts alive for months while immersed in a special antiseptic solution, and that these portions, after a comparatively short-time, surrounded themselves with living cells and grew to more than sixty times their original size.

Nourished in His Absence

When the war took the famous surgeon to France, not to return except on brief trips until 1919, it was supposed that his experiments were abandoned. Information now available shows that under Dr. Carrel's direction the embryo chicken heart which began its life eight years ago has been regularly fed and cared for until at present the scientist has gone further than to prove the possibility of his immortality for tissues.

"at the"

The doctor noticed the look and smiled, "Kindly give me your attention for a moment and I will demonstrate. You will '1st week,' '2nd week,' '3rd week,' etc., the notice that this series of test tubes is labelled tubes being larger for each succeeding week. To make you clearly understand the process, I shall start from the very beginning."

Doctor Hackensaw picked up a wide-mouthed jar in which was immersed a peculiar substance floating in a greenish liquid.

"This," explained the doctor, "is a living and growing ovary taken from a dog immediately after death. You may perhaps be aware of the fact that when an animal dies, it is some hours before the internal organs die. When a steer is slaughtered, its heart if cut out immediately after death, and immersed in a non-coagulable blood solution may be kept beating for days. In these tubes I have a specially prepared culture—fluid of my own in which any living organ may be kept alive indefinitely.

"This ovary you see floating in this jar, was taken from a female dog and contains a number of what the scientists call ova or eggs, that somewhat resemble the frog's eggs you find in the ponds in Spring. These are really eggs or egg-cells as they are called, and when matured and properly fertilized, each has the power of growing into a living puppy. Nine weeks is the time required for the growth of the fertilized egg-cell of a dog into the puppy ready to be born."

"Only nine weeks!"

"Yes, for a dog. For a cow or a human being the period of gestation is nine to ten months. Well, in this first test tube, half full of my culture fluid, I place one ripe ovum or egg-cell and then I add a very small quantity of sperm-cells from a male dog. One single spermatozoon or sperm-cell will suffice to fertilize the egg, but I add a number of them to make sure."

(Continued on page 96)

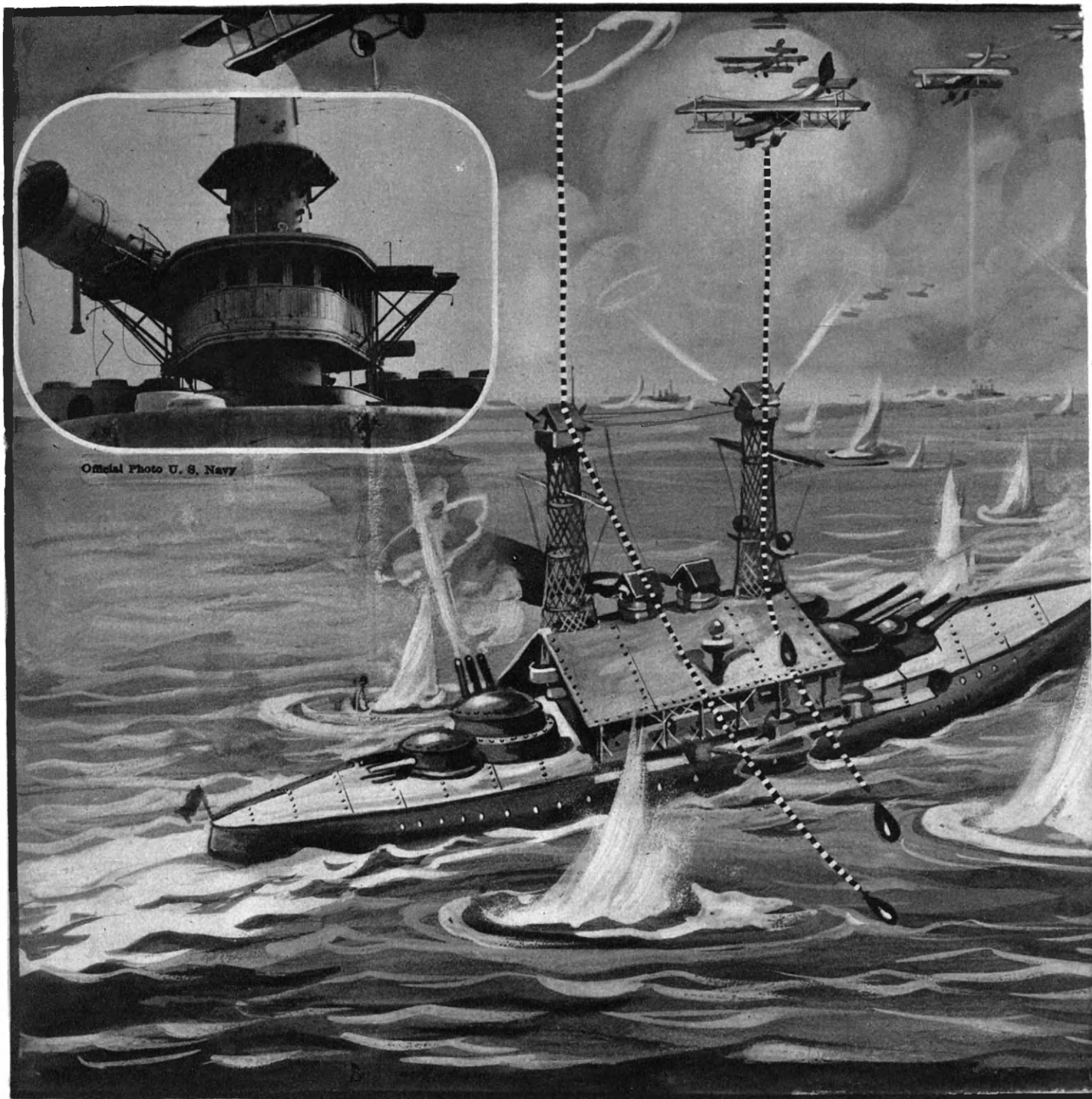

Insert Photo Above Shows What One Bomb Did to the Battleship "Indiana."

Bombing Planes Versus Battleships

THERE has been a great deal of discussion recently among naval experts as to whether or not the day of the dreadnaught or battleship has past, owing to the wonderful efficiency demonstrated by the American bombing planes in recent tests, the results of which are shown in one of the accompanying illustrations, showing a bombing target diagram.

We have always stood back of the air-plane, both in army and navy maneuvers, and the recent arguments put forth by the former Secretary of the Navy, the Hon. Josephus Daniels, have caused us to wonder if he really meant what he said, or would be willing to carry out what he declared—

stating that he would be willing to sail on board a modern battleship which would be subjected to the bombing attack of one or more airplanes of General Mitchell's Army air squadron.

Personally speaking, we would certainly rather ride in the bombing plane with the General, than we would with the Hon. Josephus Daniels in his heaviest dreadnaught, even tho it bristled with anti-aircraft guns and was armored in the very best manner. A number of photographs were taken by the U. S. Army Air Service showing the havoc wrought on the old battleship, *INDIANA* and one look at these photos, will we are sure, convince almost anybody, that it is no place for a pic-

nic or in fact for any living being on such a ship, when the bombs begin to fall.

Air Service experts sent to watch the experiments and glean information for the War Department drew somewhat different conclusions.

They found that a 1,650 pound British demolition bomb, containing 900 pounds of amatol, or ammonium nitrate and TNT, was exploded between the two smokestacks of the *Indiana*; that this bomb completely demolished the superstructure and all the upper part of the ship between the two stacks; that it cut off one stack and lifted it up onto the next deck; made two long cracks in the 8-inch barbette and drove in one of the plates of the turret about 8

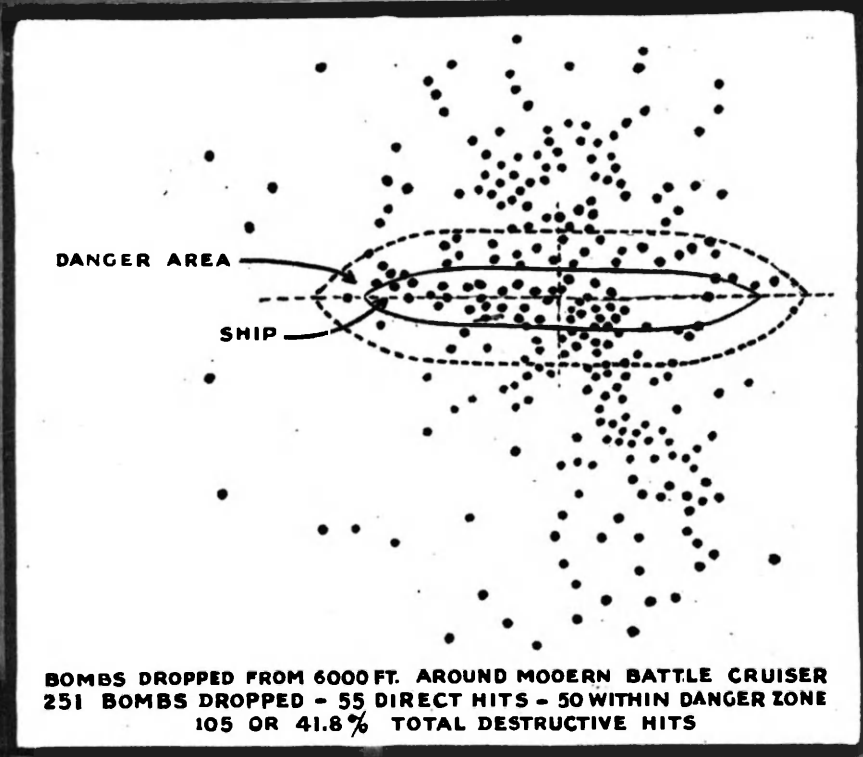
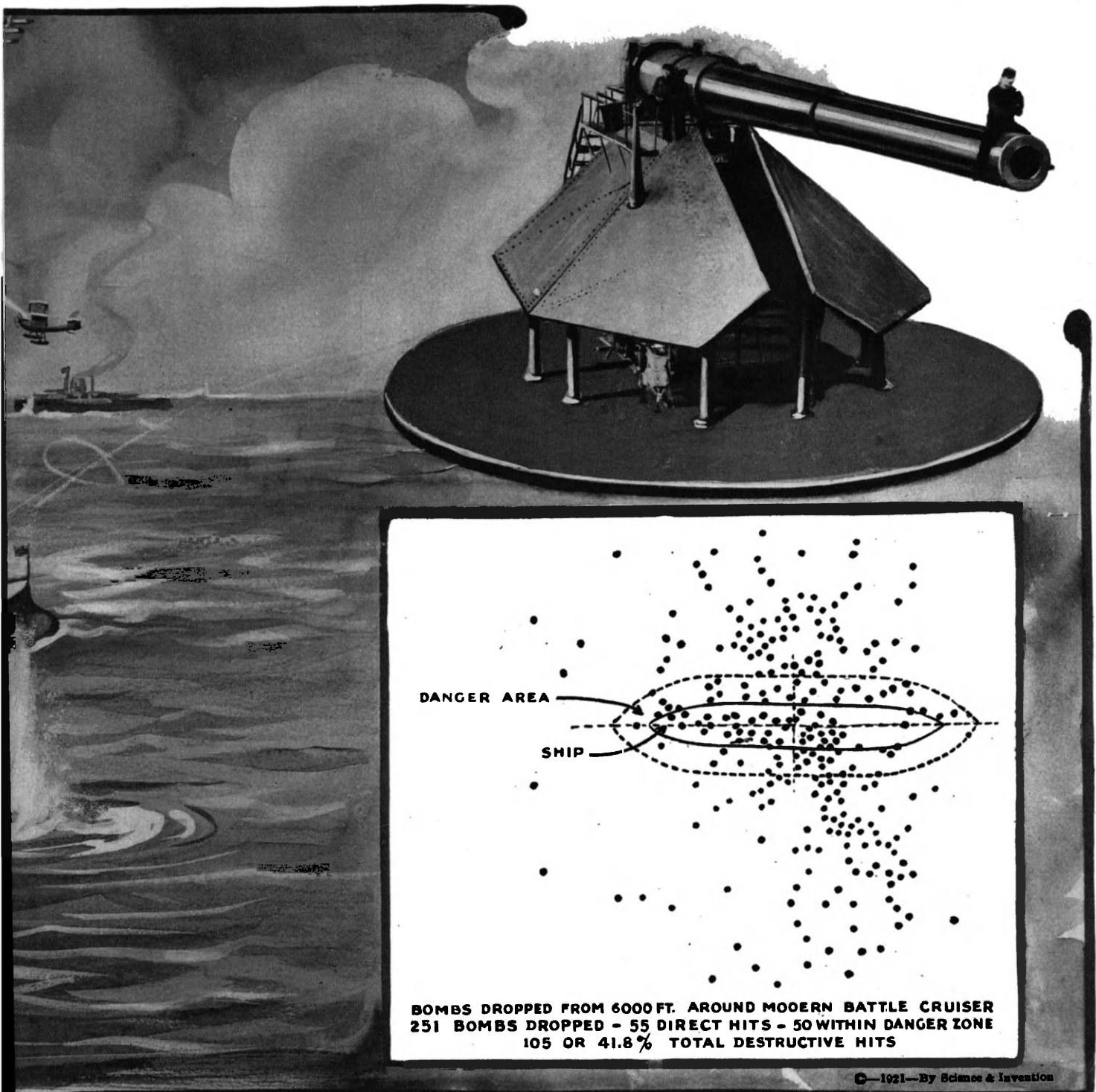

So Wonderfully Is the U. S. Air Service Trained for Offensive and Defensive Attack Against Ships Under Way That Out of 251 Bombs Dropt From a Height of 6,000 Ft. Practically Beyond Range of Anti-Aircraft Guns, 55 Direct Hits Were Registered and 50 Within the Danger Zone. This Makes 105 or 41.8 Per Cent. Destructive Hits Planted in the Vicinity of a Modern Battle Cruiser. Accordingly the Navy and Air Service Will Attempt to Determine Whether Airplane or Ship Would Be Most Efficient in Time of War. Insert Shows 35-Mile, Disappearing Gun With Aerial Bombing Protective Armor. (Photo (c) Keystone.)

inches; that the heat was so intense as to fuse the metal in several places on the side of the barbette.

The British have developed bombs weighing 3,200 pounds.

It seems absolutely certain to us that there is but one plan to follow hereafter in building warships whether they are of the cruiser, destroyer or super-dreadnaught type, because of the ever present menace of being destroyed by bomb fire from aircraft, and that is to shape the decks of the ship at such an angle that the bombs will glance off and fall into the water; the superstructure as well as the observation and range-finding platforms atop the shell-proof mast, and the smoke stacks will have to be protected by some form of slanting steel plates or meshing arranged in a manner akin to that shown in our illustration herewith.

It certainly seems that there is no use is

trying to dodge the issue as put forth by the claims and demonstrations of the army fliers, that they can, with a squadron of modern bombing planes, put out of commission one or even several of the most powerful fighting ships afloat, with a very slight chance of being brought down by shell fire from the anti-aircraft guns on the ships themselves. This latter fact was forcibly brought home by the performances of aviators during the World War; for it was very seldom that a plane was destroyed or brought down by shell fire from anti-aircraft batteries on ship or on shore—the considerable number of planes which were brought down being invariably put out of commission in aerial combat with enemy planes thru machine gun fire at short distances.

The scheme here illustrated, of covering the decks, superstructure, masts and smoke stacks, including the conning tower, with

steel plating or meshing arranged either on a single or double angle, would seem to be one of the few ways by which to combat aircraft bombers, which certainly appears to be a very serious menace and one which our navy would have to cope with if they were to go to war tomorrow with any first class power—particularly with any of the big nations which have been developing and building large aircraft.

Comparative Cost of Air Squadron

A modern super-dreadnaught requires several years' work to build, and the cost is tremendous or from forty-five million dollars (\$45,000,000) up to double this amount. For one-third of the first amount, or for \$8,000,000, a squadron of powerful bombing planes, capable of traveling at a speed of 150 miles an hour or more, including carrier ship can be built and made ready for duty in a much shorter time
 (Continued on page 80)

Colloidal Fuel Process

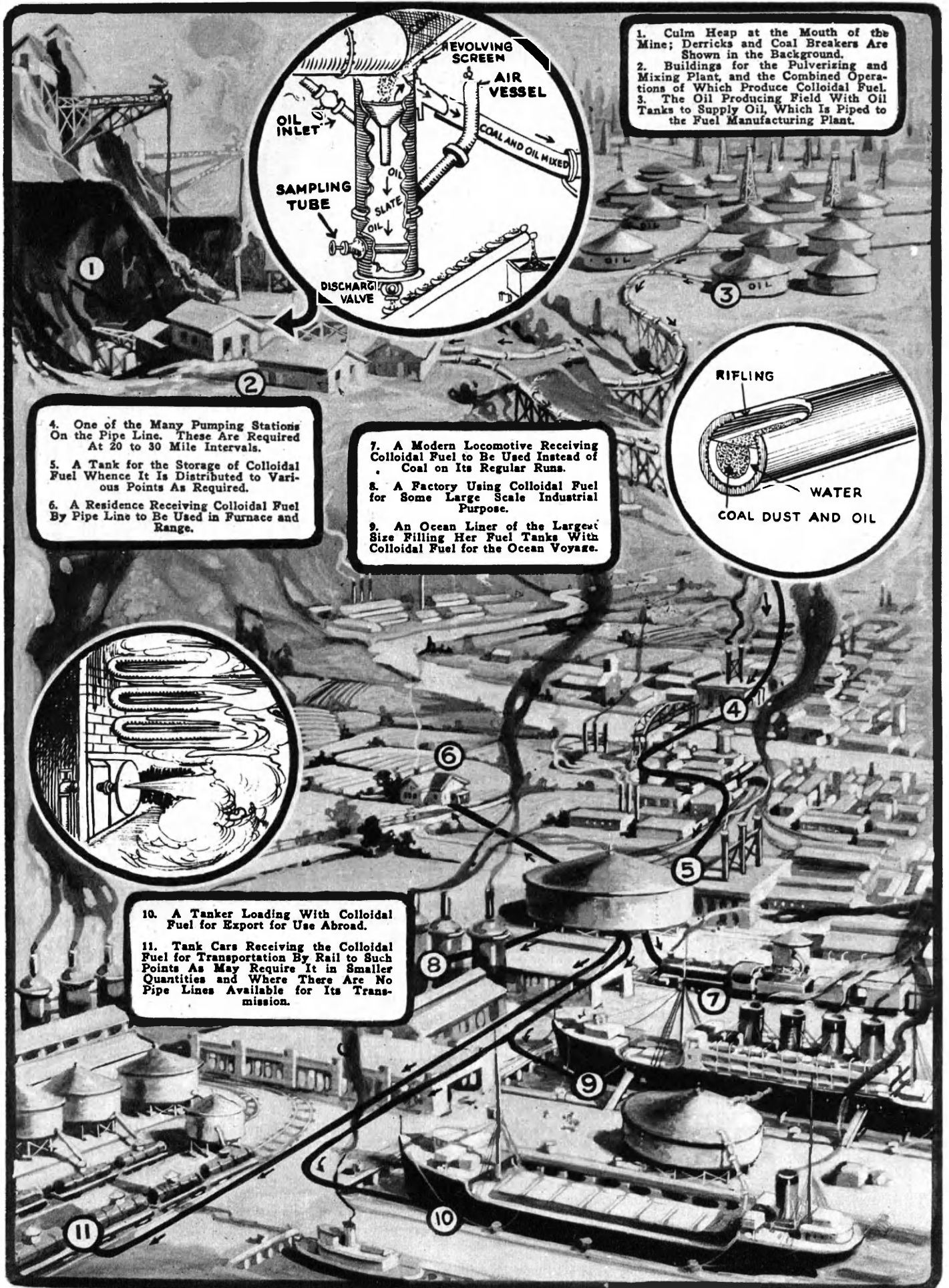

1. Cullm Heap at the Mouth of the Mine; Derricks and Coal Breakers Are Shown in the Background.
 2. Buildings for the Pulverizing and Mixing Plant, and the Combined Operations of Which Produce Colloidal Fuel.
 3. The Oil Producing Field With Oil Tanks to Supply Oil, Which Is Piped to the Fuel Manufacturing Plant.

4. One of the Many Pumping Stations On the Pipe Line. These Are Required At 20 to 30 Mile Intervals.
 5. A Tank for the Storage of Colloidal Fuel Whence It Is Distributed to Various Points As Required.
 6. A Residence Receiving Colloidal Fuel By Pipe Line to Be Used in Furnace and Range.

7. A Modern Locomotive Receiving Colloidal Fuel to Be Used Instead of Coal on Its Regular Runs.
 8. A Factory Using Colloidal Fuel for Some Large Scale Industrial Purpose.
 9. An Ocean Liner of the Largest Size Filling Her Fuel Tanks With Colloidal Fuel for the Ocean Voyage.

10. A Tanker Loading With Colloidal Fuel for Export for Use Abroad.
 11. Tank Cars Receiving the Colloidal Fuel for Transportation By Rail to Such Points As May Require It in Smaller Quantities and Where There Are No Pipe Lines Available for Its Transmission.

Colloidal Fuel

By PROF. T. O'CONOR SLOANE, Ph.D. LL.D.

COLLOIDAL chemistry has attracted much interest in late years among chemists. Altho the discovery and investigations of the colloidal state of matter date back many years, it is only recently that the importance of this state of matter has been realized by the scientific world. Many phenomena, long unexplained, are now accounted for by the colloidal state. Briefly speaking, it implies a division of solid matter into so fine a state, that it occupies a ground halfway between the solid and liquid state when it is suspended in a proper carrying-vehicle, and which may be water, oil, or in the case of precious stones, a mineral substance, such as silica in semi-precious stones or alumina in the ruby.

If goldleaf is fastened to a plate of glass by size as in gilding letters on windows, a single thickness of it will permit green light to pass thru. This indicates an approach to the colloidal state of thinness. If it is treated with potassium cyanid it can be still further thinned until it passes a purple color. The red color of the ruby is attributed to some such condition as that just described; finely divided metal is probably held in colloidal suspension by the crystallized alumina, so that the color is produced by colloidal transparency, quite comparable to the green and purple light-transmitting qualities of the goldleaf.

The pharmacist has long used emulsions in which a mucilaginous or thickening compound is made to hold in suspension finely divided solid material or even microscopic globules of a liquid. The well-known emulsions of cod-liver oil are instances of such compounds.

If coal is ground to the finest powder, it can be held in suspension by petroleum fuel oil, if a proper fixateur or thickening compound is added in small quantity. The thermic value of the mixture is not far removed from that of the fuel oil, gallon for gallon, and it is just simply a question of relative prices, as to whether a cheaper fuel is produced by the mixture than by the oil or powdered coal alone. But back of this there is a very important economic problem involved.

Coal Dust and Oil a Liquid Fuel Which Can Be Piped

In the coal regions there are today enormous piles of culm, which is the refuse from the coal breakers. These piles of culm have accumulated in past decades and every year adds to their volume. They consist of a mass of rather finely divided slate and coal mixed. The ash may run as high as 70 to 80 per cent, while it is known that if the slate is separated the residual coal dust may have but three per cent of ash so that it will be a very efficient fuel.

We now come to another point. The grinding and pulverizing machinery of recent date has been brought to a very high degree of perfection as regards its economy of operation. There has been an enormous demand for pulverizing machinery, notably by cement works. It is a simple matter to pulverize culm, and after pulverization the slate can be separated by a sort of floatation process. Imagine the powdered mixture poured into the upper end of a pipe thru which a slow current of liquid, in our case we will call it fuel oil, is rising. The slate is much heavier than the coal, and the upward rising fluid can have its rate of motion adjusted so that as it overflows from the upper end of the pipe, it will carry with it the pure coal dust, while the heavier slate sinks thru it to the bottom of the apparatus and is removed and thrown away, unless a use for the slate dust in making cement or other material can be developed.

By establishing a pulverizing plant in the coal regions in connection with the floatation separator alluded to, any desired mixture of fuel oil with almost pure coal dust can be produced, thus utilizing the waste from the mines. Now it is quite possible that the oil would be thick enough to almost keep the finely divided coal in suspension, but after the floatation, it may be assumed that it will be proper practise to add to it a thickening substance, to act as fixateur.

We now may consider that we have suggested a way of producing in the coal regions, a very efficient colloidal fuel to all intents and purposes, a *liquid fuel*, and its transportation has to be provided for. Adequate pipe lines would supply this service. The mixed fuel could be cheaply piped from the distant coal regions to any locality where it is to be used, as from western Pennsylvania to the seaboard, or to the Alleghany and Ohio River system.

One suggestion to improve the pipe line transportation is to pump water along with the colloidal fuel thru pipes whose inner surface has spiral projections or lands upon it, similar to the structure of a rifled cannon. The idea is to set the mixture of colloidal fuel and water into rapid rotation so that the heavier water is thrown in cylindrical form against the sides of the pipe, the oil never touching the metal carries its load of pulverized fuel thru what may be termed a liquid pipe to its destination. Every few miles pumping stations will be established exactly as in the present pipe lines and the transportation plant will be exactly comparable to the present system of petroleum transportation.

Our illustration suggests what may be done to carry out this system of utilizing the waste products of our coal field. The descriptive notes cover the separation of slate and coal, the production of the colloidal fuel, the pipe line, the tanks for holding it, its delivery to freight cars for local transportation, discharging it directly from the coal field into the fuel tanks of ships, and its use for all sorts of purposes, even for the domestic consumer.

Cheap pulverization and cheap floatation can produce a fuel of very low ash content from the vast culm heaps which have accumulated and are accumulating day by day, all over the coal areas of the country. By utilizing them the impending coal and oil famine with which the world is supposed to be threatened could be postponed many years. For colloidal fuel, such as described would make a hundred parts of oil go nearly twice as far if a sufficient quantity of coal dust could be mixed with and carried by it.

The Silent Conductor

In many of our cities, we are very familiar with the "speaking conductor" on the trolley-cars. As a street is approached, this individual calls out the number or name, as the case may be, and not always in an intelligible voice. This is a very primitive and unsatisfactory way of reaching the result desired, the notifying passengers, and sometimes it is dispensed with and the passengers are allowed to find each one his own street by inspection of the street signs on the corners. It has often seemed strange that a better system has not been devised and put into practise long before this.

In the city of Quebec an apparatus known as the *silent conductor* has been installed in the trolley cars. It rolls and unrolls a display sheet upon which the

names of the streets are printed. The mechanism is connected with different parts of the car so as to be controlled by the conductor, wherever he may be,

if the car is of the type where the conductor moves about. If however, the car is of the pay-as-you-enter type, where the conductor is always in the same place, a single connection is sufficient.

We illustrate a couple of examples of Quebec's trolley street indicator. It is interesting also to notice how the bilingual feature of Quebec is brought out in the French rendering of "Next Street"—"Rue-Suivante."

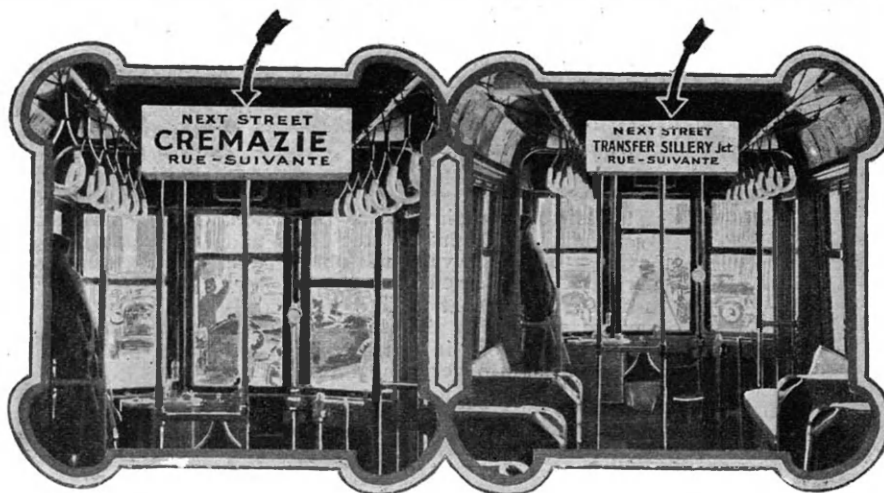

Radium in Cancer Treatment

By JOSEPH H. KRAUS

IN therapeutics, radium may be applied either as a salt or the pure emanations may be used. Both salt and emanations emit three kinds of rays, *alpha*, *beta* and *gamma*. The alpha rays have such a slight therapeutic effect that it is practically negligible. These rays have been found to consist of positively charged atoms of helium which are projected from the radium at a velocity of about one-fifteenth that of light. These particles are easily absorbed by thin metal, glass, paper, rubber or even air, and are also deflected by intense magnetic fields.

The beta rays are far more penetrating than the former and vary considerably as to their velocities. They are negatively charged and are distinguished by the terms soft beta, medium beta and hard beta rays. Their speed is approximately that of light, and they are more easily deflected by intense magnetic fields, than are the alpha rays.

The gamma rays, very much like X-rays and light, are extremely penetrating and cannot be deflected by magnetic fields. Therefore it seems that the latter two rays are the only ones of practical value in radium treatments. In addition to these rays, secondary rays are set up by the passage of gamma rays thru metals. These rays cause considerable irritation, and therefore, when the rays are filtered thru a screen, some agency is generally used to absorb them, such as paraffin, wood, paper or rubber.

In the past we have dealt with the use of radium salt and the radiations therefrom for therapeutical purposes, and we will therefore not delve into this subject to any great extent; but we will consider the use of radium emanation applicators and the process of collecting the emanations. A brief resumé, however, of some of the other forms of applicators using the salt of radium would not be amiss here.

Inasmuch as radium bromid is very unstable and deliquescent it is always converted into the insoluble sulfate before being fixt in the treatment apparatus. There are two forms of these apparatus in general use: first—applicators of various strengths, whose area ranges from one to thirty square centimeters and which may assume the rectangular square or circular contour and which are fitted with screens for proper filtration; and second, tubes. These are made from glass and are extremely small. The radium sulfate is tightly packed to prevent any movement in the two-tenths to three-tenths centimeter tube.

The radium salt applicators have one advantage over the emanation apparatus, in that the radio-activity emitted by the salt is practically constant over considerable periods, and therefore, when the apparatus used for applying such salt has once been made, it requires no further attention. With the emanation apparatus this last difficulty is overcome by the addition of further tubes of the radium emanation.

As can be seen in our photographs the apparatus for collecting radium emanation is quite complicated. The basis of supply consists of a quantity of radium dissolved in acidulated water

and kept in vials in a vault. Running into the vault and connecting with the vials, containing the radium are glass tubes connected at their other ends to mercury vacuum pumps and leading thru vessels which collect water vapor and impurities. After a period of action of the vacuum pump, the mercury in the various receptacles is lowered considerably, and the tops of the re-

ceptacles now contain radium emanation. By regulating the proper stop-cocks and turning off the vacuum pump, the mercury is allowed to ascend and to force the emanation into long capillary glass tubes. These are subsequently sealed off, in short lengths and thus divided into very short tubes, and are then inserted into the proper apparatus or applicators for treating patients. This is shown in the photographs. Some of the emanation tubes are inserted directly into small silver containers and are then used in the

various applicators. The screening of the radium emanation is effected directly by such applicators and it is a comparatively simple matter to remove weak tubes and insert stronger tubes of radium emanation when necessary. In order to treat diseases to advantage, it is necessary that the rays be properly screened and because of this, very great responsibility falls upon the radium technician. The rays can be filtered thru metals such as silver or platinum, but immediately, due to the action of the rays on the metal, unless the metal is extremely thin, a secondary radio-activity is set up from the metal. This in turn is sometimes filtered by a few centimeters of air or by wax or paraffin, wood or rubber. The power of the ray must be carefully measured and the length or duration of time for treatment must be watched so that a burn will not result. So prominent has radium treatment become, that it is now being used by all the first class hospitals in cases which have been diagnosed as being inoperable. A peculiar and one of the most successful forms of radium treatment is that cited below.

In some cases of tumor, tubes containing from one to two millicuries of radium emanation are inserted directly into the diseased mass by means of a trocar and are left in situ in the tissues. This trocar is very interesting from both the scientific and mechanical standpoints; it consists of a tube of capillary diameter in which operates a plunger so as to resemble a hyperdermic syringe of very minute caliber. The end tapers off to a point. The inner plunger is first retracted, one of the small glass emanation tubes is inserted into the space below the plunger, and the entire trocar is then pushed into the diseased mass of tissue. Instead of forcing the plunger down, and in that way driving the glass tube bodily into position, the plunger is held fixed while the outer casing is drawn upward. Of course the effect is identical in either event, but due to the fact that these tubes are so tiny and break easily, an attempt to force the emanation tube into the tissue, would subject such tubes to an unnecessary strain and perhaps cause them to break, whereas by the method employed, it is a relatively easy matter to allow one of the tubes to rest in a hole already made for it by the metallic trocar.

Of course the different forms of diseases and the different methods of treatment are so varied that no definite assertion as to what should and should not be done, can be given; but in view of the large number of cures in inoperable malignant diseases, it would seem that the radium treatment has at least the ability to stay the disease for a long period of time.

The great advantage in using the emanation apparatus shown in the photographs and in using the emanation tubes, lies in the fact that the intrinsic value of the tube of emanation is comparatively slight and if a tube and applicator should be lost, the applicator alone would be considerably more costly to replace than the minute tube of emanation.

Feature June Articles

Recording Earthquakes—How the Seismograph Works, with description of home-made models. Explained in popular style, with photos of apparatus. By Prof. T. O'Connor Sloane, Ph.D., LL.D.

Will the Helicopter be the Flying Machine of the Future? Answered in picture and story by E. H. Lemonon, French Aero Engineer.

Why Insects Fly Toward the Light. By Dr. E. Bade.

How the Mississippi River Actually Runs Up-hill. With illustration of this scientific paradox.

"The Deflecting Wave"—A thrilling tale of radio and luck. By Herbert L. Moulton. Illustrated in Rotogravure.

Scientific Illusions—Master tricks of great magicians explained so you can do them. The "hot oven" trick—escaping from packing boxes, steel boilers, glass trunks, et cetera, all explained.

French Marionettes that Dance and Play—with Remarkable Photos.

Just a Drop of Water—with startling micro-photos of water droplets. By Dr. E. Bade.

How the Size of Betelgeuse Was Measured by the Interference of Light Waves—with photos and diagram of the actual apparatus used.

The "Loop Aerial" and its Applications. By Robert E. Lacault. Fully illustrated with photos and diagrams of audion circuits employed in French Army Signal Corps.

The Secret of the Atom. Explained in story form. By Clement Fezandié. No. 2 of Dr. Hackensaw's Secrets.

And the usual Rotogravure section containing photos of the latest happenings in Science.

ceptacles now contain radium emanation. By regulating the proper stop-cocks and turning off the vacuum pump, the mercury is allowed to ascend and to force the emanation into long capillary glass tubes. These are subsequently sealed off, in short lengths and thus divided into very short tubes, and are then inserted into the proper apparatus or applicators for treating patients. This is shown in the photographs. Some of the emanation tubes are inserted directly into small silver containers and are then used in the

RADIUM IN CANCER TREATMENT

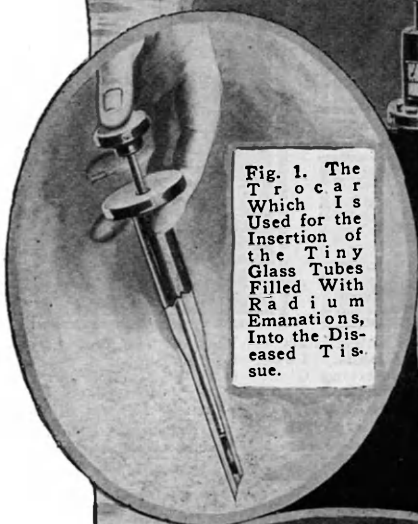

Fig. 1. The Trocar Which Is Used for the Insertion of the Tiny Glass Tubes Filled With Radium Emanations, Into the Diseased Tissue.



Fig. 2. Above Is Shown a Round Metallic Disc Covered With Radio-Active Salt. Below: A Tube of Radio-Active Salt, Stitched Into a Cavity.

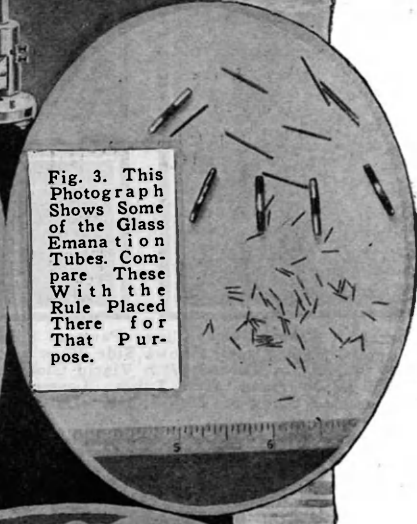

Fig. 3. This Photograph Shows Some of the Glass Emanation Tubes. Compare These With the Rule Placed There for That Purpose.



Fig. 4. Several of the Applicators Used in the Treatment of Various Diseases By the Radium Emanation Method. In Rear a Carrying Case.

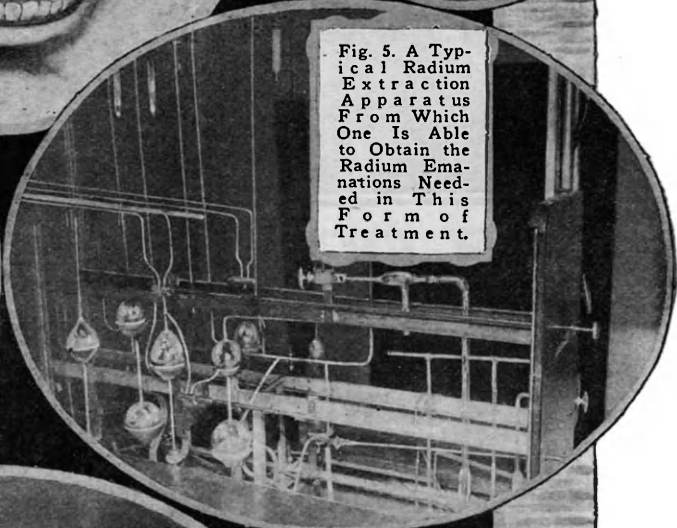

Fig. 5. A Typical Radium Extraction Apparatus From Which One Is Able to Obtain the Radium Emanations Needed in This Form of Treatment.



Fig. 6. Radiumized Lead Foil Is Used in Treatments of the Cornea of the Eye. Lower View: Applying One of the Applicators Seen in Fig. 4.



Fig. 7. For Treating Affections of the Stomach a Tube Is Used Thru Which Passes a Wire, Carrying a Radium Salt Container.

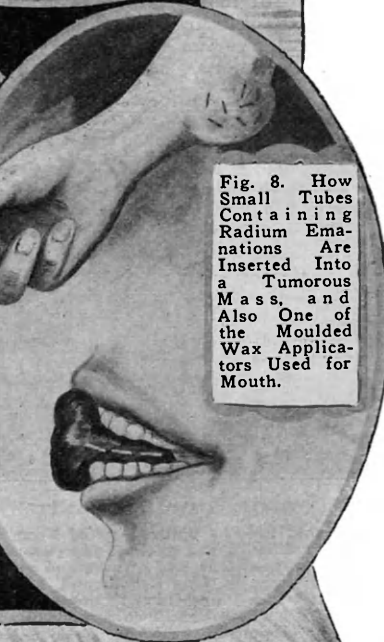
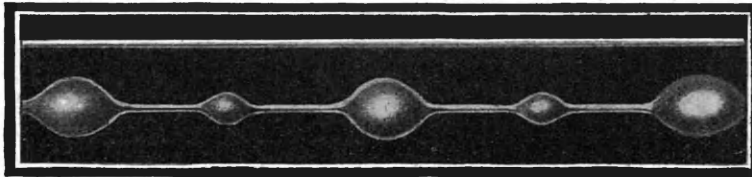
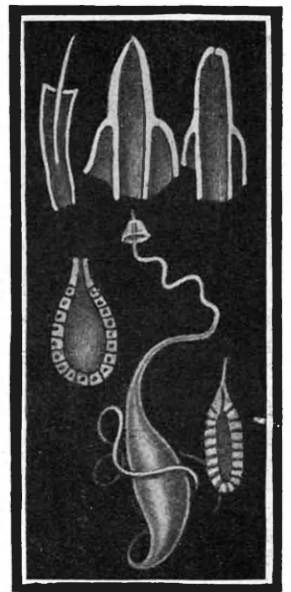
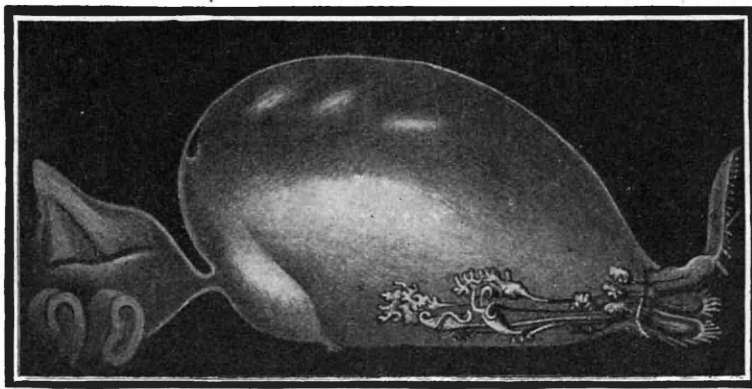
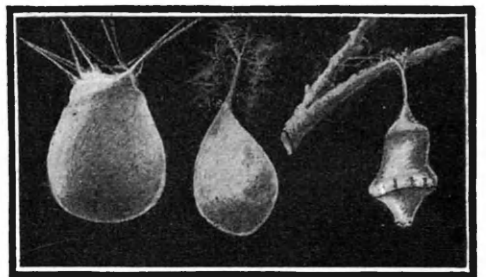
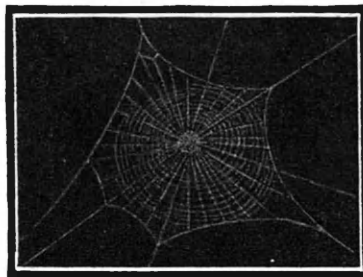
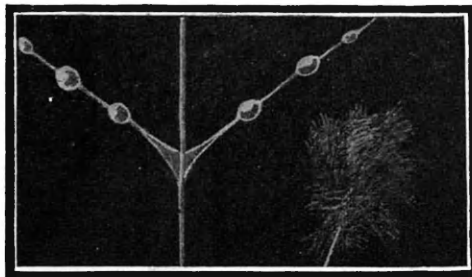

Fig. 8. How Small Tubes Containing Radium Emanations Are Inserted Into a Tumorous Mass, and Also One of the Moulded Wax Applicators Used for Mouth.



Upper Left View: Shows Three Pairs of Spinnerets and the Cribellum—Another Spinning Attachment; Lower Part of View Shows One of the Spinnerets. Top Center Shows Side View of Abdomen of Spider Showing the Spinnerets With Their Glands. Lower Center Shows a Smooth Glossy Variety of Thread With Viscid Globules. Top Right: Three Varieties of Spinning Tubes and Connecting Glands from Which Silk for the Threads Is Delivered to the Tubes. Lower Left: Method of Cementing Spiral and Radiating Lines Together in a Spider Web, Showing Disk Used for Attaching Ends of Web Lines. Lower Center: Orb-web of Common Garden Spider. Lower Right: Showing Egg-sacs of Three of our Common Spiders.



Cobwebs

By WILLIAM M. BUTTERFIELD

SPIDERS, of all the tiny creatures of the earth, are the most despised and feared. Superstitions, current among all peoples, have for centuries torn their reputation to shreds and scattered the pieces (figuratively speaking) so as to fall topsy-turvey in the form of inapt references.

Spiders are extremely timid and rarely show themselves in the open. Entire scientific collections, sometimes several

thousand specimens, have been gathered in the field by turning over stones, ripping away the bark of logs and dead trees, or by whipping the grass and bushes with a butterfly net,—the usual methods of the collector, without the enthusiastic scientist having, in all of this varied experience, had an actual view of a spider constructing a web, egg-sac or nest.

The only daylight exhibition of spinning,—all other varieties being consum-

mated in the black hours of night,—is the binding of a victim with a rough swathing of silk in the hunting snare or web. Even the killing and devouring of the unfortunate fly or locust is deferred if an observer be near, until some more private hour. Popular understanding or legend cannot, therefore, be founded upon much actual knowledge of the spider.

(Continued on page 88)

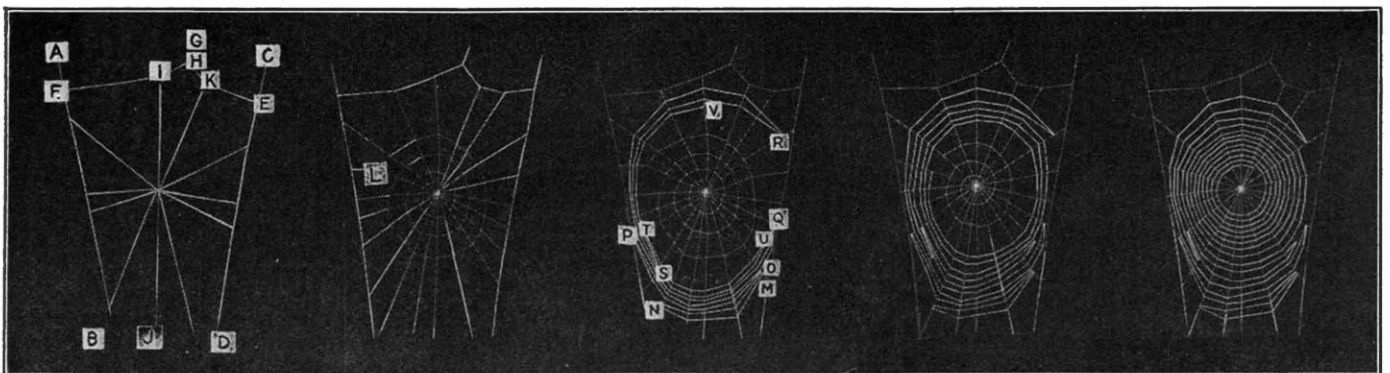

Photo from American Museum of Natural History

Left to Right: 1.—The Spider Started From a Branch Above A and Dropt to Another Branch Below B, Spinning a Thread and Fastening It. She Then Climbed On This Thread to the Upper Branch, Crossed Over to a Point Above C, and Dropt to a Point Below D, Making a Strand As Before. Then Going to E, She Fastened One End of a Strand and Spinning It Behind Her, Went Across By Way of the Upper Branch to F. She Then Went to the Upper Branch and Dropt to This E-F Strand, Fastening the New Line At Point H. This Pulled E-F Up Slightly. The Next Strand Which She Put in Was From Point I to a Point On the Lower Branch Below J; Pulling This Line Made Another Angle in the Cross Strand E-F As Did the Following Line From K to B. These Last Two Strands Were Fastened Near Their Center By a Bit of Silk and the Remaining Radii Were Put in By Moving About On the Foundation of the Web. 2.—The Next Step in the Operation Was the Laying Down of the Primary Spiral Which Is Shown in This Plaque and Which Ended At L. All of These Threads Consist of Smooth, Tough Silk Which Is Not Sticky. From This Point On, the Spider Uses the Sticky Threads Which Constitute the Real Snare. 3.—The Details of Putting in the First of the Sticky Threads Vary Greatly. The Spider Started At M and Its Course May Be Followed by the Letters to V. From V She Continued in a Regular Spiral Until the Primary Spiral of Smooth Silk Was Reached. She Then Cut Away the Outer Portion of the Primary Spiral So That She Might Have More Room for the Snare. 4.—The Process of Cutting Away the Primary Spiral and Putting in the Sticky Spiral Is Shown About Half Finisht On This Plaque. 5.—This Plaque Shows the Complete Web With Nearly All of the Primary Spiral Removed.

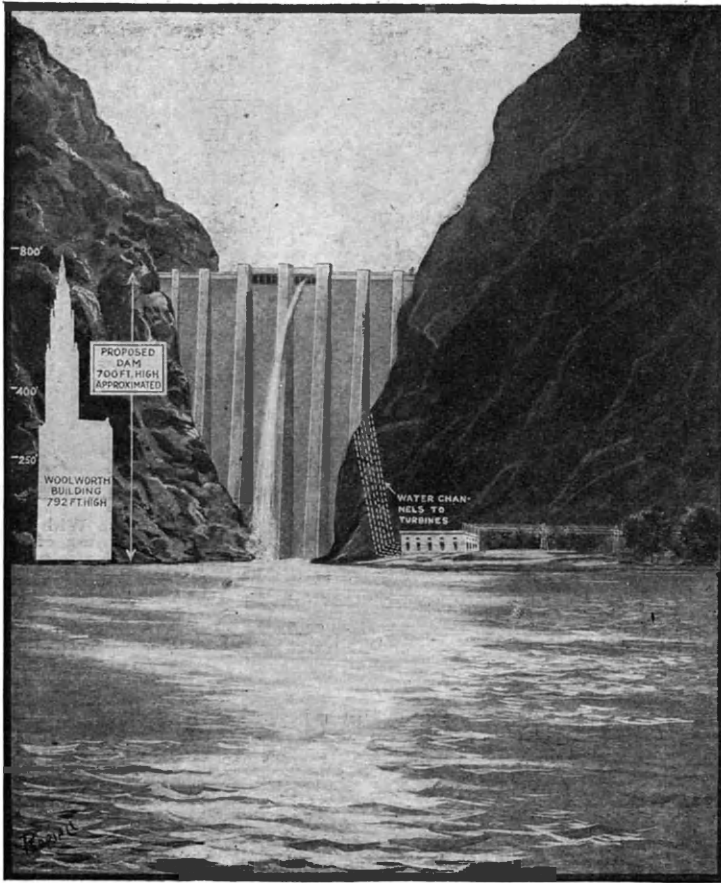

Illustration at Left Shows what Will Undoubtedly Be the World's Highest Dam, 700 Ft. High and 300 Ft. Wide, Which Engineers Propose to Build At the Entrance to Boulder Canyon in the Colorado River, the Dam Site Being Located in the South-eastern Tip of Nevada, As Shown in the Map At the Right. The Rocky Nature and General Appearance of a Section of Boulder Canyon Is Shown in the Photo Above. The Reservoir Formed by Thus Flooding Boulder Canyon Will, Besides Serving to Irrigate a Tremendous Area of Arid Land, Provide for the Development of About 600,000 Kilowatts of Electrical Energy for Lighting and Power Purposes. The Electrical Power Developed, Which Is to Be Secondary However to the Irrigation Requirements, Can Easily Be Transmitted Several Hundred Miles At a Potential Well Over 200,000 Volts.



Boulder Canyon Dam 700 Feet High and 300 Feet Wide

WHAT will undoubtedly be the world's highest dam, will be the one which the U. S. Reclamation Service proposes to erect at the lower entrance to Boulder Canyon in the Colorado River, located in the southeastern tip of Nevada. Uncle Sam's engineers and geological experts have been making examinations of this site for a considerable time and have been making borings of the earth and rock in various vicinities with a view to the best location for the erection of a dam, which according to the latest reports made to the Department of the Interior, calls for a structure some 700 feet high and approximately 300 feet in width; its height is almost as great as that of the famous Woolworth Building which measures 792 feet. The height of the Woolworth edifice compared to that of a dam of this magnitude is shown vividly in the accompanying illustration.

Thru the courtesy of Mr. A. P. Davis, Director of the U. S. Reclamation Service, who kindly supplied the photographs with the successive elevations marked upon them in feet, as surveyed by the U. S. Geological Survey, the present illustration of the dam as it will appear has been worked up by our artist from an actual photograph of the entrance to Boulder Canyon. When this dam is completed and which it has been estimated will require the services of approximately 25,000 men for five years, the waters of the Colorado River, thru Boulder Canyon, will be impounded into a vast reservoir or storage lake, having an area according to the U. S. Geological Survey, of about 131,000 acres, or 205 square miles.

The principal reason for all this vast development of the Colorado River water

power, is not primarily the furnishing electric power to the country adjacent to this region, but it is proposed by its aid to irrigate the vast tracts of arid land in lower California; the Boulder Canyon reservoir and dam scheme constituting only a portion of the solution of the many gigantic problems involved in the irrigation of the entire Imperial Valley and vicinity, covering an area of nearly 1,000,000 acres, an area of over 1,500 square miles.

As aforementioned, the chief aim of those who have become interested in the Imperial Valley project, and also specifically in the Boulder Canyon reservoir construction, is for the purpose of irrigation, and to provide for a vast water storage which will serve to irrigate these lands in off years, when there is very little rainfall. The development of electric power, is, in any case, to be of secondary importance.

The following paragraphs taken from one of the official communications sent to the Director of the U. S. Reclamation Service, brings this out clearly:

"—We feel that in the development of hydro-electric power, the fundamental object of the proposed reservoir's construction (Boulder Canyon) should never be lost sight of; that regardless of the desirability of maximum electric power production, the water level in the reservoir should be held at such levels, as will at all times control the flood water and will provide adequate irrigation water during years of low-water run-off."

Electric Power from Boulder Canyon

In the official report on the Boulder Canyon development of the Imperial Valley

project, the following data is given on the possible electric power development at this site, the water necessary for running the dynamo turbines being carried down thru suitable penstocks and tunnels cut thru the solid rock, to a power-station situated near the base of the dam. The amount of electrical power which can be generated at this dam with a 320 foot effective head acting on the turbines, is stated to be 600,000 kilowatts.

Many trainloads of cement will be required to build this towering dam, which will be equal in height to a 54 story skyscraper, as shown in our illustration. The electric power developed at this site can be distributed over high voltage transmission lines for great distances—possibly 300 to 400 miles, or even more. At the present time, electric power is not transmitted any farther than about 200 miles as it has not proven economical to do so with the present voltages in use. Two hundred thousand volts is about the highest potential which has been found satisfactory for the distribution of electrical energy over considerable distances, owing to the fact that at potentials in excess of this, there is a considerable loss due to leakage over the insulators and to loss by corona or brush discharge.

The voltage employed for high tension distribution lines has been steadily increased, however, and with the improvements on which electrical engineers are busy working right along, it appears very possible that by the time this Boulder Canyon irrigation and hydro-electric development will have been completed that both the transmission line voltage and the distance over which the energy is distributed, may easily be two to three times what it is today.

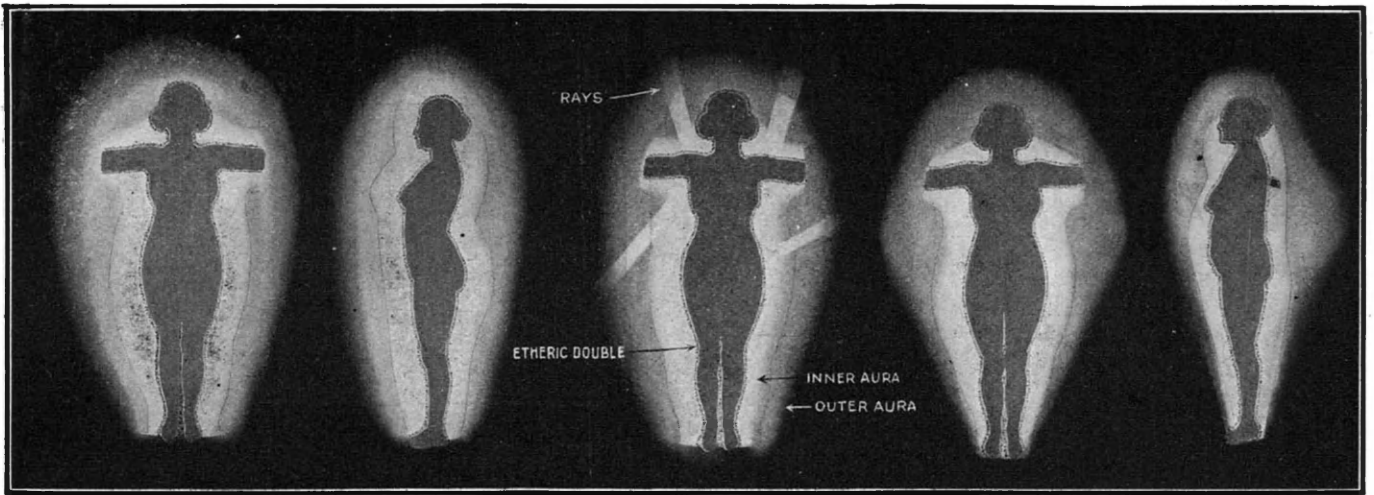

Above: The Aura of a Healthy Woman. This Is a Perfectly Shaped Aura of Average Width Enveloping a Young Woman, 23 Years Old. The Color Was Blue Gray. This Is a Very Fine Specimen of Aura. A Dicyanin Screen Is Usually Required to Make the Aura Visible, but After Becoming Used to the Effect Many Experts Can See It Without the Screen.

This Shows an Aura of a Healthy Woman and Also Shows as Well the Rare Phenomenon of "Rays" Breaking Out from Various Parts of the Body. These Rays, However, Are Non-luminous. They Are Simply an Emanation. The Age of the Subject Was Twenty-five Years.

Health Has a Good Deal to Do With the Aura. The Above Shows an Aura of an Hysterical Woman. Note Particularly the Bulge at the Back. Also Note That the Outer Aura Is Wider in Shape Than Normally. The Subject Was a Young Girl and Rather Emaciated. In This Case the Inner Aura Was Striated.

The Human Aura

By H. GERNSBACK

Member of American Physical Society

THERE is nothing new about the human aura. It has been written upon and discusst since antiquity; many clairvoyants and those endowed with psychic powers have claimed to see the human aura or atmosphere. This as a rule has been scoffed at by most scientists until very recently. The researches of Walter J. Kilner, B.A., M.B., M.R.C.P., late Electrician of St. Thomas' Hospital, London, are astonishing in so far as they have brought the supposed psychic phenomenon down to ordinary physical terms. Dr. Kilner was convinced that the human aura existed and his researches then were concerned mainly in trying to make it visible. He considered many different means and first thought that the forces were situated in the infra-red portion of the spectrum. This, however, did not prove to be the case and in 1908 he thought of certain dyes that might be of use. Finally, after many trials, his researches became fixt upon a certain coal tar dye *dicyanin*, and with this dye he obtained the best results. The full details are described in his recent book, "The Human Aura."

One of our illustrations shows how such a screen is made. It is composed of two pieces of flat glass separated by means of rubber or glass or any other suitable substance. The space between the two plates is filled with an alcoholic solution of dicyanin. It should be noted that this solution does not retain its full strength after it has been used for a long time, and therefore should be renewed frequently. Dr. Kilner had no sooner finished the first screen than he tried its effect; when he looked at a friend thru it he saw around his head and hands a faint mist, grayish in color, and concluded that this could be nothing else than the human aura. In the course of his early experiments it was not very long before he noticed that he could see for a few minutes the haze *without* using the screen at all. This power, however, lasted only for a short time, but could be renewed by looking thru a dark screen towards the light.

Dr. Kilner found that the dicyanin seems to have a peculiar effect upon the human eye. As a matter of fact persons who looked thru the dye found that their eyesight was improved temporarily. He also found that dicyanin had a harmful effect upon the eyes making them so painful that it was necessary after experimenting with the screen, to cease work for days at a time. For this reason very dark screens should not be used for a longer time than one hour daily. (By dark and light screens is meant chiefly a change in the strength of the solution. A light solution is made by using more alcohol and a dark solution by using less alcohol.)

The aura can only be satisfactorily seen when certain conditions are fulfilled. In the first place the light must not be too bright. The requisite amount has to be determined

window. This window was fitted with an ordinary blind at the top, and below another blind consisting of two thicknesses of black serge, that could be raised to any desired height. The serge permits a considerable amount of light to pass thru, in fact too much, except on very dark days; but the illumination is further regulated by lowering the ordinary blind. This arrangement is convenient, as a slight gap can be left between the two blinds, allowing extra light to pass into the room.

It is important to bear in mind that the subject should stand at least a foot in front of the background, to prevent any shadows or marks on it from producing optical illusions, and vitiating the observations. Trouble from this cause, however, is not likely to occur, unless the investigator is new to the work.

The dicyanin screen should be held quite close to the eyes in order that all light striking the eyes' retina shall first pass thru the blue fluid. Without this precaution the screen has little or no effect upon the eyes. The influence of the screen on the eyes usually persists for an hour or more, but sometimes on the first few occasions for a much shorter period, when the operation may be repeated as often as necessary.

The human aura according to Dr. Kilner is composed of three parts. First, we have the *etheric double* which is a dark space surrounding the entire form of the human body. It is a dark band without any striation or granules adjacent to the body and quite distinct from the aura proper.

We next have the *inner aura* which lies just outside the etheric double. As a rule the breadth is uniform all over the head and trunk, and generally, but not always, slightly narrower down the limbs. The inner aura is striated as if brushed out with a camel's hair brush.

We then have still another aura—the so-called *outer aura* which envelops both of the other auras as may be noted from our illustrations. The outer aura commences on the outside of the inner aura and varies in

*T*HERE can be no doubt of the existence of the human aura which has now been made visible by means of "Dicyanin," a coal tar dye. There is nothing occult about the Aura. Walter J. Kilner, B.A., M.B., M.R.C.P., late Electrician of St. Thomas' Hospital, London, Eng., in his explanation of the human aura says that we have to do here with an ultra-violet phenomenon. The aura is not ordinarily visible to the naked human eye, unless re-inforced by a dicyanin screen. It is a new subject of great importance, and we know our readers will be much interested in Dr. Kilner's researches.

at each observation, and experience is the only guide, as some persons can best perceive the aura when the light is much too bright for other people. Roughly, the body of the person under-examination should be just distinctly visible after the observer has become accustomed to the dimness. The light should be diffused proceeding from one direction only, and illuminating the subject equally all over. The best arrangement is obtained when the observer is standing with his back to a darkened window while the subject faces it. It is always essential to have a dead black background for the subject.

A large portion of Dr. Kilner's work has been conducted in a room with only one

size. When the whole aura is observed without the intervention of any screen, the two latter divisions appear blended together, but the part nearest the body looks the more dense.

For the first trials in viewing the aura, the subject should be in good health and if possible robust, as the aura always loses its distinctness during illness. While the subject is undressing and getting into position for examination, the observer should look thru a dark dicyanin screen towards the light (clear sky but not directly into the sun) for a few seconds. The light in the room should

.....
 The Aura of a Healthy Strong Man; the Subject in This Case Was an Athlete Thirty-three Years of Age. The Color of His Aura Was Blue With a Little Gray. The Etheric Double Will Be Noted Laying Close to the Body. In This Case It Was Very Clearly Defined. It Measured About One-Quarter of an Inch Broad. This Aura Was Unusually Coarse.

then be regulated by the window blinds, as mentioned above; then standing with his back to the window and opposite to the subject (using a pale dicyanin screen if necessary) the observer should distinguish immediately, and certainly after a few seconds, a faint mist enveloping the body. This mist varies even in health according to age, sex, and individual peculiarities. The next thing to observe is the texture of the aura, whether fine or coarse, as no two persons have identical auras. Note the color which is generally some shade of blue mixed with a greater or lesser amount of gray.

As mentioned no two auras of any two individuals are the same. The aura of a male subject is entirely different from the aura of a female subject. The female aura is larger than the male one, as will be seen from our illustrations. The male aura seems to be narrower. The aura of children also varies, but for children of both sexes up to the age of thirteen or thereabouts, the auras are of about the same general formation. Illness, hysteria, diseases, etc., all affect the aura, while various illnesses affect the auras in different ways.

Dr. Kilner in his experiments found that the aura could be



In trying to explain the phenomenon of the human aura, Dr. Kilner thinks that it is due to ultra-violet rays. Mr. Gernsback sets forth the theory that Dr. Kilner merely has made visible the odorous envelope surrounding the human body. The emanation given off by a piece of scented soap, for instance, is very material. If you could make this scent visible, you would see a misty "aura" surrounding the soap.

Has Dr. Kilner made odors visible?

influenced also from the outside by various physical means. Thus for instance, he found that vapors of chlorin and bromin greatly affect the aura. Electrifying a subject tends to greatly enlarge the aura for the time being. The effect is as follows:

The subject stood upon an insulated stool and was positively electrified by means of a small Wimshurst static machine. The whole aura disappeared temporarily and a few minutes after returning had enlarged to ten inches around the head and trunk, six inches in front, nine inches at the back and six inches by the leg.

Dr. Kilner was also able to observe another phenomenon which he termed "Rays." It seems that not all individuals are able to produce these rays. There are usually two rays, one from each shoulder proceeding upwards, also several other "rays" that may break out from other parts of the body. These "rays" are, however, rather faint.

It may be noted here that the aura is never visible in absolute darkness. In other words, it is not auto-luminous in the sense

.....
 Effects of Electricity on a Boy's Aura. This Is the Aura of a School Boy 11 Years Old. He Was Positively Charged by Means of a Wimshurst Machine. The Aura Took Rather a Long Time to Depart, But Afterwards When It Had Completely Returned, Was Found to Be Expanded More Than Usual. In All Cases Electricity Causes Auras to Disappear Due to Electrification, But It Returns Afterwards.

that certain fishes give off a luminosity or fluorescence.

What then is the explanation of the human aura? Dr. Kilner is of the opinion that we have to do with an ultra-violet phenomenon which normally is invisible to the human eye. By means of dicyanin screens the phenomenon, whatever it may be, becomes visible to the human eye.

The human body is normally a heat en-
 (Continued on page 68)

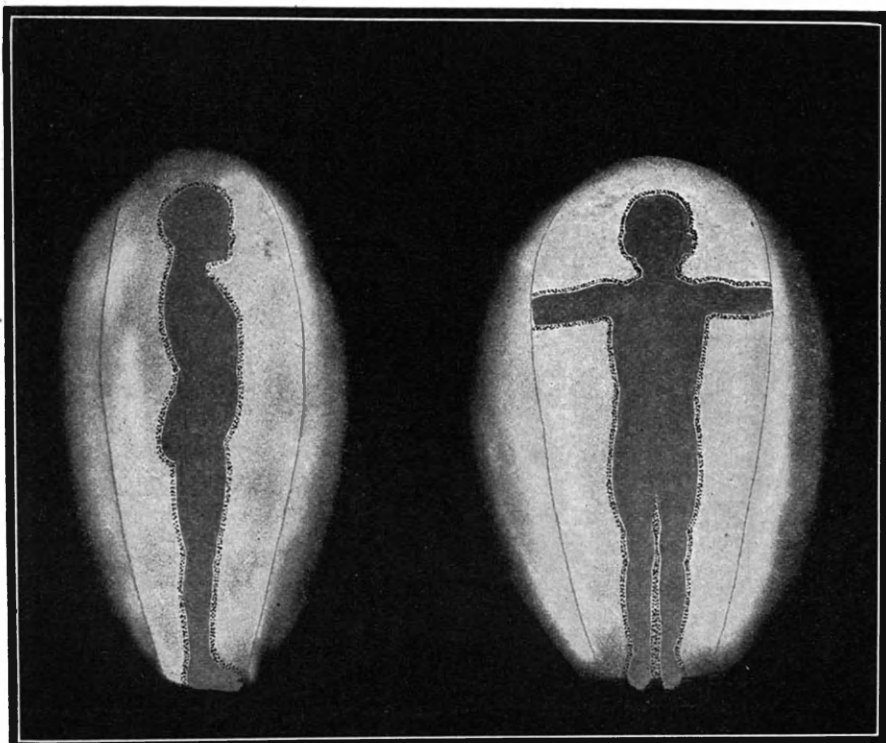

Remarkable Siberian Habitation

ONE of the most curious and remotely situated types of dwelling houses, almost unknown to the eyes of civilization, is located under the Arctic circle in the extreme northern provinces of Siberia. This is one of the coldest inhabited regions of the earth, where the temperature often falls to 80° below zero. The accom-

Photo At Left: Curious Primitive Year, Month and Day Calendar, Made of Birch Wood, Used By the Siberian Native Fur Hunters Who Make Long and Remote Journeys, Worn Suspended From the Neck. The Days Are Kept Track of By Inserting a Peg in the Holes. The Two Photos Below Show Exterior and Interior of a Siberian

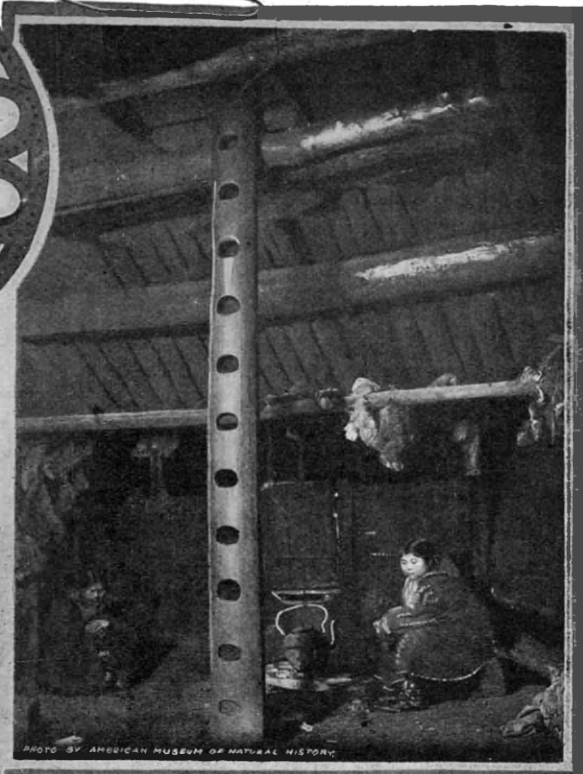
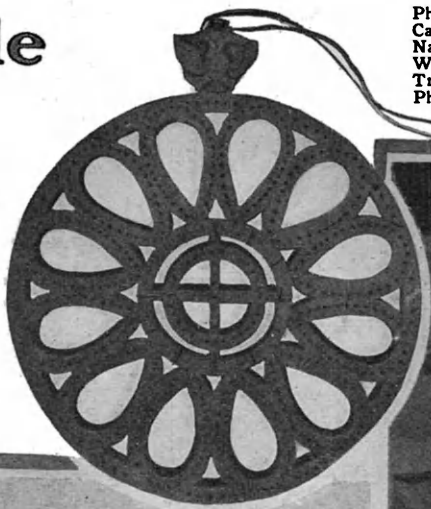

House in the Far North. Entry Is Made By Climbing Down the Perforated Pole in the Center, Thru An Opening in the Roof.



panying photographs show the weird looking exterior and interior of one of these remarkable subterranean habitations. From a distance the house has the appearance of some huge and open funnel rising out of a snow bank. The crater-like top, besides forming a roof, is used as a general storing place for food and all sorts of articles. It slopes downward to an aperture in the center, which serves as a smokehole, ventilator, and passageway below. A number of logs arranged in a circle support the framework of the roof, the lower end of which rests on

a secondary pile of timbers, forming the slanting walls of the interior. For nearly nine months of the year the whole house is banked and covered up almost to the protecting roof with tons of snow, chinked in with frozen earth and debris. This brings the inmates at all times about ten feet below the surface. Undoubtedly the most astonishing feature of the house is the means of entrance. This is accomplished by first scaling a narrow split log on the outside, extending down from the roof, having holes cut in it for the feet and hands. The interior is reached

by descending another perpendicular hewn stairway covered with a slippery coating of grease and soot, the safe descent and ascent of which none but a native can successfully accomplish. The inclosure has an earthen floor, and is barren of anything in the shape of furniture. Large copper vessels for cooking seal meat and blubber and a kettle, used for melting snow are the chief household utensils. The diet is limited almost exclusively to fish and to half-cooked seal and whale flesh, with Russian brick tea as an occasional luxury. A dozen or so of both sexes, usually relations, inhabit a dwelling. Small skin sleeping booths, some six feet high by five in width, heated by a lamp in the center, are arranged around the walls.

Liquid Rheostat for Small Currents

The liquid rheostat in which conducting electrodes are immersed in liquid electrolyte, and whose resistance is caused to vary, by changing the immersed area of the plates, has very extensive use, generally where very heavy currents are employed. The apparatus illustrated in the cut, shows a very neat application of the same principle to smaller currents, adaptable for the home laboratory and small current regulation. A glass vessel of diamond-shaped horizontal section holds the fluid—salt and water, potassium carbonate solution or even sulfuric acid. Two triangular carbon plates are carried on axes extending across one of the diagonals of the vessel as clearly shown in the cut.

By rotating these plates outward towards the free angles of the vessel, their im-

mersion area is diminished. There are three ways of doing this, the adjustment therefore being determined by a pin. On one of the axes, there is a knurled disc for rotating the shaft. By adjusting the pin, one plate may be rotated while the other stays stationary. This gives a gradual change of resistance. Another of the adjustments throws both plates into gear, so that by turning the knurled button the plates move away from each other, as when opening a book. This gives double the rapidity of adjustment. Finally, by operating with the pin alone, one of the plates can instantly be swung up giving a very rapid change in resistance, instantly opening the circuit if operating as a switch.

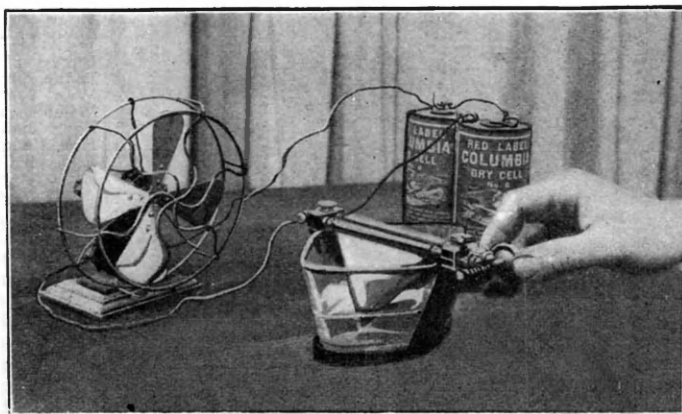

New Water Rheostat Suitable for Laboratory and Other Requirements.

Optical Lenses Colored by Electricity

By HARRY ROSENTHAL

Consulting Engineer

BY a new electrical process *white optical lenses* are treated so that the structure of the glass is modified. This re-arrangement of the material gives the glass a slight tint or color. The lens so treated is more comfortable to the eye than a colorless lens, as the treatment changes the lens so that it cuts out the irritating forms of light and does not allow them to reach the eye, and it does it in a manner which no ordinary chemically colored lens can do.

The development of lenses, particularly colored lenses, is the result of man's desire to see with greater acuity and less effort; to produce this result it is necessary to eliminate the irritating rays which cause discomfort and strain. The white optical lens, after being treated by this new process, has the same qualities and characteristics and is capable of performing the same functions as the original clear glass which has been tinted or colored by the slow action of sunlight extending over many years. The colors obtained were amethyst, amber, green and yellow tints.

In using this method in connection with optical lenses an almost ideal condition exists, viz., in using finished white optical lenses which are made of the best glass obtainable, and then treating it, we obtain a glass which has characteristics valuable to the oculist, it long being known that when eye-glass lenses are made of sun-tinted glass, such lenses would shade the eyes of the person wearing them from the actinic rays of the spectrum. Besides changing the irritating rays of light of the actinic spectrum, it is also necessary that the glass transmit to the eye as much of the visible spectrum as possible, and this should be done with the minimum distortion of color value. Lenses treated by this process transmit a maximum amount of light in the visible spectrum and with practically no color distortion. This is the only lens which accomplishes this, and how well this is done is shown by tests

made at the Bureau of Standards Laboratories, Washington, D. C.

gases—Helium—is present. This would then mean that we were on the threshold

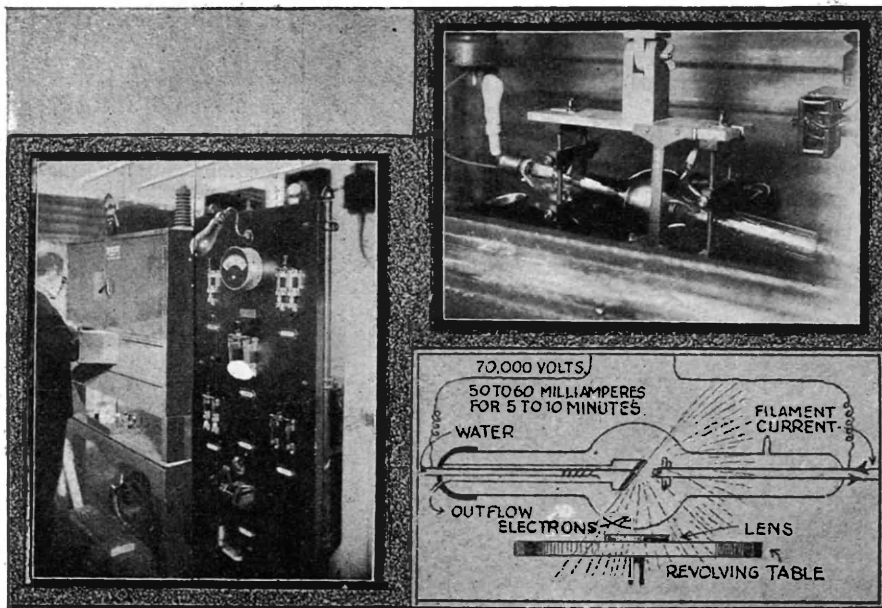

A Novel Method of Treating Optical Lenses Whereby Color Is Imparted to the Glass By Treating It With Powerful Electronic Discharges Emanating From a Special Form of a Tube Resembling Greatly the Coolidge X-ray Bulb. At the Left Is Shown the Switchboard and the Lead-enclosed Cabinet Which Houses the Apparatus. The Optical Lenses Are Placed Upon a Circular Conveyor Which Brings Them Two At a Time in Position Under the Tube.

If white optical glass before treatment is carefully analyzed the exact ingredients can be determined; then taking some of the same glass and subjecting it to treatment by this process it is again analyzed, a remarkable change will have been noticed to have taken place. Traces of the rare gases are now present, and some of the scientists who have carefully investigated kindred reactions, have definitely determined that one of the rare

of the old Alchemists' dream, namely, the transmutation of matter from a lower order to a higher one. The changes which take place in the glass are not on the surface—but permeate every part of it. The result is permanent, samples of glass which were originally treated by this process in 1914 and were tested and left at the Bureau of Standards in Washington, were again tested in the latter part (Continued on page 66)

A Novel A. C. Motor

A NEW alternating current motor with novel characteristics was recently patented by Russell E. Taylor, M. E. This was designed to operate on single phase, alternating current and its outer and inner fields may be either connected in parallel or series; or one field may be wound with a secondary and the current from the latter used to excite the other field.

A peculiar feature of this motor is that it has no commutator, and no slip

made up of laminated iron and wound for an outside current.

The stationary coil element is located between the poles, its core is also composed of laminated iron, and has the general contour of a cylinder with projecting teeth as shown in our illustration. This element is supported by an auxiliary shaft so that it can be moved with ease in either direction, but is normally stationary when the motor is operating at a definite speed previously determined.

The movable element or rotor of the motor is made up of non-magnetic end plates having bearing sleeves, one of the latter having connected to it the pulley for giving mechanical power. Between the end plates, are a series of supporting parts of non-magnetic material into which are slotted soft iron or steel elements spaced so as to be uniformly distributed.

When the stationary element in the center is shifted to either side the motor immediately starts to run, dependent on the direction toward which the lever is shifted, and full torque is obtained from the moment of starting, with the motor running at just a few revolutions per second, to the time when it is operating at a higher rate of speed than synchronous.

Here Is Something Absolutely New in Alternating Current Motors Whereby the Inventor Is Able to Obtain Full Torque at Any Speed and Change From Full Speed in One Direction to Full Speed in the Opposite Direction, Without Employing Moving Parts, Switches, Commutator, Slip Rings or Any Form of Speed Regulators. A Lever Shifting the Plane of a Stationary Coil Mounted Inside the Rotor Performs All These Functions.

rings, and will operate on any cycle with a wide range of voltage. Altho it is capable of a very high-speed, it operates equally well on all speeds from zero to its maximum with full torque at any of these speeds, and it runs in either direction. The speed and reverse control is operated by a single lever and no switches of any kind are required. Essentially it consists of a field frame

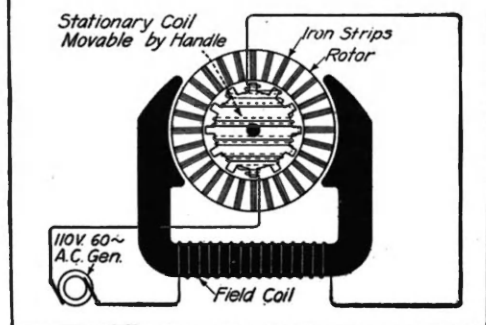
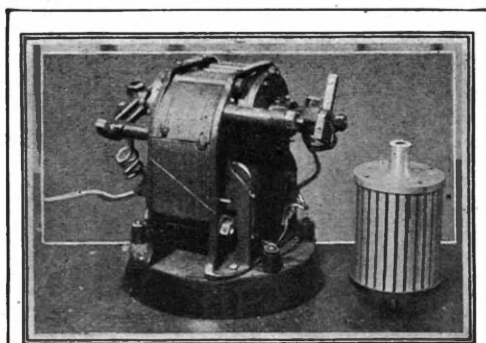

Loud-speaking 'Phone Calls Streets



Latest Loud-Speaking Telephone Used to Call Streets on New York Subway Train.

Installed under the direction of E. E. Trafton, telephone engineer of the Brooklyn Rapid Transit System, the loud-speaking telephone has already proved its worth.

The loud-speaking telephone makes the announcing of stations, etc., a comparatively simple matter. Very little effort on the part of the guard or conductor is required. No shouting, no straining of the voice is necessary. The man making the announcement places the transmitter to his mouth, and in tones that are no louder than those necessary when using the ordinary telephone, he calls the name of the station, or "watch your step" or anything else, for that matter. The result is startling, for in all parts of the car and at times even out on the station platform, it is possible to hear the announcements clearly.

For the tests that have been conducted to date, the necessary apparatus was installed in only a single car, but Mr. Trafton says that these same tests have proved that it is possible, with the loud-speaking telephone, for one man to do the announcing for an entire three-car train and to do it with no more effort than is required for one car.

This equipment is made possible by the use of new principles in the design of telephone apparatus. The loud-speaking receivers, which are installed in the ceiling of the car near the doors, are hardly visible. The openings are about eight inches in diameter, but are screened over and are thus not noticeable. The receiver is electrodynamic, with separately excited fields, all working in series across the emergency car lighting batteries.

The other main feature of the equipment is a high efficiency transmitter with a "button" of exceedingly great capacity which is filled with a substitute for regular granular carbon. The mouth-piece is peculiar in shape, as may be seen in the illustration. The four "petals" with the openings on the sides make it possible for the man using the instrument to place it much closer to his mouth, *without muffling the tones* as would be the case with the ordinary round mouthpiece.

In operating directly across the emergency car lighting circuits this transmitter, permits of the modulation of very powerful electric currents which in turn actuate the vibrating diaphragm of the receiver with the required energy for the reproduction of speech sufficiently loud to be heard above the noise of trains in operation.

The transmitter is small and can be carried in the pocket or held comfortably in one hand. To it there is attached a cord similar to the operator's cords on a telephone switchboard. On the end of the cord is the plug which the guard places in a telephone jack that is directly above the buttons with which he operates the doors of the cars and signals the motorman

1/10,000,000,000th Atmosphere Vacuum Pump

By L. A. HAWKINS *

SCIENCE and industry have produced many triumphant feats thru the agency of "vacuum," for in it there can be no loss of energy thru heat conduction and matter cannot decompose by oxydizing. So the degree of achievement has been in proportion to the perfection of vacuum attained. Many machines have in the past been devised to extract as much air as possible from containers. Suction pumps are sufficient even today for exhausting such containers as electric light bulbs, but for the higher grade vacua such as those required for Coolidge X-ray tubes and for high power tubes for wireless use a mechanism of much higher efficiency is required. Many types of pump have been designed to produce a specially high vacuum, but the crowning triumph in their construction was reached when Dr. Irving Langmuir devised his mercury vapor mechanism, since come to be known as the *Langmuir Condensation Pump*.

This device is not only the most rapid of all high vacuum pumps, but it also will produce the highest vacuum yet attained by man.

It came into being as the result of efforts to get higher and higher vacuum for the purpose of research and to obtain this condition quickly. The pump, in spite of its remarkable effectiveness, is simplicity itself in operation. It has no moving mechanical parts. A stream of mercury vapor, produced by a small electric boiler, and moving at high velocity, entraps and sweeps along with it the air or gas molecules from the vessel undergoing exhaustion and delivers them to the rough pump, which ejects them into the air while the mercury vapor itself is condensed and flows back into the little boiler.

Like most new tools of science the Langmuir Condensation Pump has found a field of great practical utility. All the Coolidge tubes, which have revolutionized X-ray practise, and all the high power radio tubes, or *pliotrons*, as they are called, which have made long-distance wireless telephony practicable, are exhausted by this pump.

Its speed has been stated in this way—it will reduce the pressure in a 1-liter vessel (approximately 1 quart) from 100 microns (approximately 1/10,000 atmosphere) to 1/100 micron (approximately 1/100,000,000 atmosphere) in two seconds.

But such a statement, while it tells the whole story to a physicist, does not mean much to a layman, so suppose we put it this way—since a million is about as large a number and a second about as short a time as have a real meaning to the average man, how long would it take to accomplish the result above stated if, from the vessel in question, we removed a million molecules a second? The answer is 750,000,000 years!

(Continued on page 89)

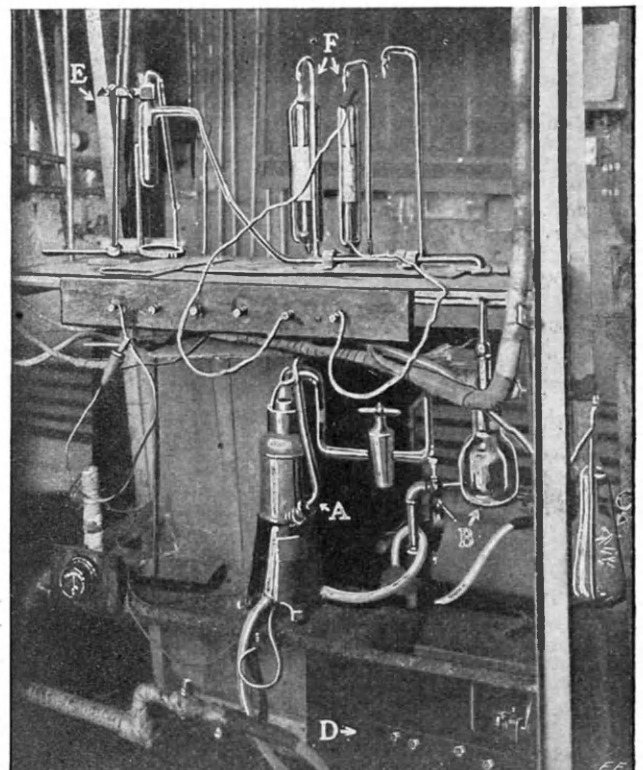

Langmuir Condensation Pump. Secures Most Nearly Perfect Vacuum Known by Passing Blast of Mercury Vapor Across Mouth of Vessel to Be Exhausted. A, Langmuir Pump Mounted Over Electric Furnace. B, Liquid Air Trap. C, Trap for Mercury. D, Rough Pump Into Which Langmuir Pump Exhausts. E, Oven Hood Shown Raised. F, Tubes Being Exhausted.

* Engineer, Research Laboratory, General Electric Co.

Electric Light from Spigot

M. COLARDEAU, former professor of Physics at the Lycée Ronlin and a scientist of European reputation, has just explained to the Academie des Sciences of Paris how electric light may be obtained from the kitchen tap. By a simple calculation, the eminent physicist showed how an ordinary water tap turned to allow the flow of one quart of water per second would furnish the equivalent of one horse power, provided the source of the water supply was situated at 75 meters above the level of the tap. By mounting a turbine on the tap and connecting it with a dynamo, sufficient current is obtained to light one 500 candle-power lamp and 20 other lamps varying from 10 to 50 candle-power. Every time the tap was turned on for domestic uses, the miniature electric station would work and accumulate in a storage battery the otherwise wasted energy of water. The professor has installed such a system in his own home. This is the water tap power plant which has set the scientific world talking about the utilization of wasted energy.

In his house he uses no other installation, and it never gives out and never costs him anything. In the country places M. Colardeau would use the wind to pump water up to the required

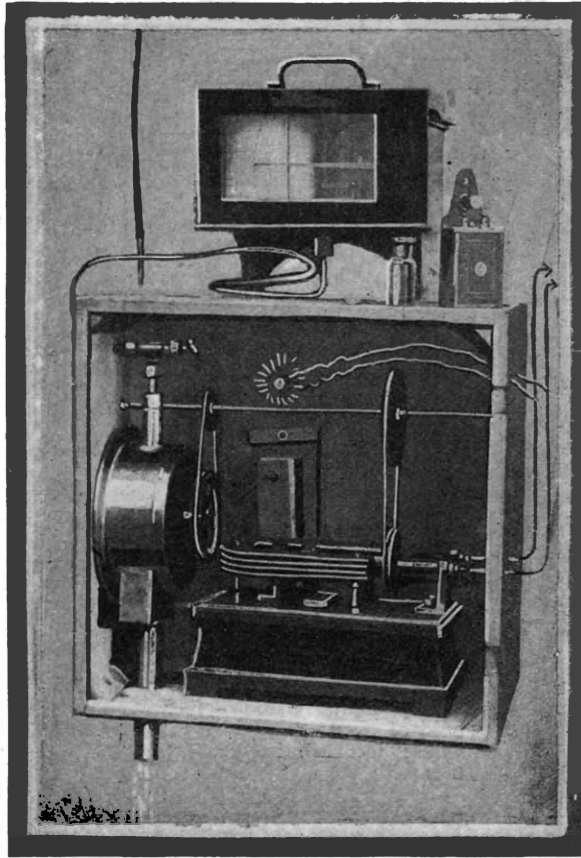

heights, and so transfer the wind energy into water energy, which would be transformed into electric energy.

"When we've done that," he concluded, "we needn't any longer worry about the exhaustion of our coal stocks."

Wind power was wasted wholesale, but even more culpable was the waste of water-power within one's own house.

The Accompanying Photograph Shows the Actual Spigot Power Plant Employed by the French Scientist, M. Colardeau. Every Time the Spigot Is Operated, the Water Discharges Thru the Water Motor Shown at the Extreme Left of the Cabinet, Which Motor Is Geared by Belts and Shafts to the Magneto Dynamo Shown in the Lower Center. The Energy from the Small Dynamo Passes into a Storage Battery Where It Is Accumulated, and It Is Said that M. Colardeau Has Supplied His Own Electric Lights from This Source Continuously, Without Having Resource to the Central Lighting Station.

"The force of every kitchen and bathroom tap is wasted," he declared, and he put forward a scheme which he believes can be made practicable to utilize the force from the water that runs from every kitchen tap, which Paris derives from a reservoir 200 feet above the city.

(This apparatus was described also in our January, 1921, issue. —Ed.)

Amateur Moving Picture Apparatus

By **PIERRE MARECHAL**

THERE are several parlor apparatus for the exhibition of moving pictures, but all of the models now in use have the great defect of requiring that the views or films be purchased from the makers. But it is very nice to be able to take one's moving picture film oneself; in this way one can conserve, better than by plain photography, the memory of the family, which we can bring to life again on the screen and preserve incidents in our life adaptable for the same development.

The professional apparatus for taking pictures is expensive and beyond the means of the every-day amateur. A French inventor, M. Baudot, has developed a photographic apparatus which can take a little picture on a $3\frac{1}{4} \times 5\frac{1}{2}$ plate and the same apparatus can project the views as taken upon a screen 20x24 inches.

With all these advantages the mechanism is very simple; a handle turns the plate which advances one-fiftieth of a turn each time that an exposure is completed. This gives a series of small images which

are produced upon the plate in the shape of a circle.

The plate is developed and from it a positive is taken on glass by contact. This positive is put into the apparatus which acts as the projection lantern. The lamp which projects the images is contained in a cylindrical chamber; it is an electric lamp which projects its rays upon a condenser which sends the rays, parallel and uniform, thru the plate. The plate is turned by a handle, the same one which serves for taking the pictures.

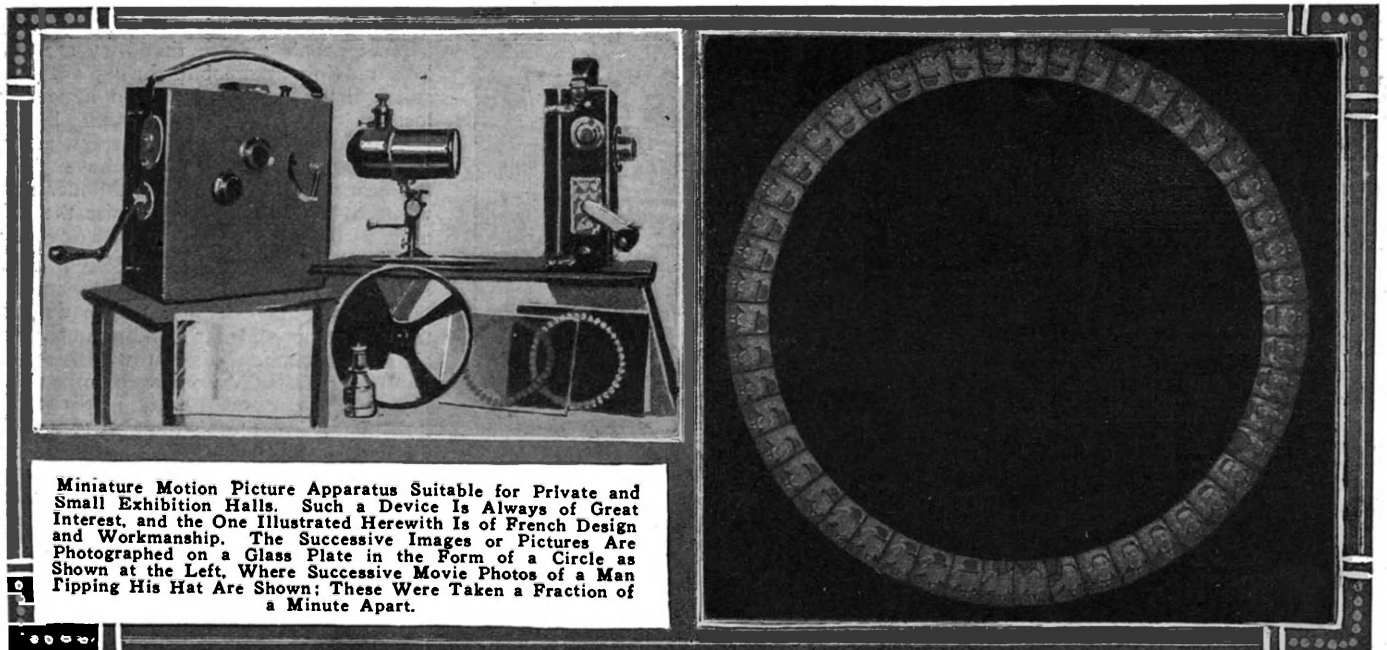

Miniature Motion Picture Apparatus Suitable for Private and Small Exhibition Halls. Such a Device Is Always of Great Interest, and the One Illustrated Herewith Is of French Design and Workmanship. The Successive Images or Pictures Are Photographed on a Glass Plate in the Form of a Circle as Shown at the Left, Where Successive Movie Photos of a Man Tipping His Hat Are Shown; These Were Taken a Fraction of a Minute Apart.

Speaking of Teeth Like Pearls



VARIOUS sporting notabilities have acquired a certain amount of notice from the standpoint of their having gold teeth or having diamonds set in their teeth, and in a recent United States patent awarded to Anderson Copie Solmon Robinson, is described what the inventor considers a simple and effective means for applying jewels or precious stones to a tooth or teeth.

The general idea is to set the jewels in metal, which is shaped and adapted for being inserted between teeth or clamped upon a single tooth, or attached to a crown, the effect of which is that it is not necessary to make a special filling in the tooth to which to attach the jewel.

Our sketch shows how useful this setting is for repelling the attacks of robbers—now so painfully and disagreeably frequent.

Lightning Versus the Motor-Car

WHERE do you think you are safest in a thunder storm—in a moving motor-car or out of it? This is a surprising question, or at least the answers that one generally hears on all sides when this question happens to come up for discussion, are surprising.

It is rare, it seems, that lightning strikes a moving automobile, but it does happen now and then, and the results are frequently quite serious owing to the large mass of material surrounding the occupants, particularly the driver who has hold of the steering wheel and whose feet are in good contact with the metal foot pedals

during the month of August, a peculiar case of lightning striking an automobile occurred. A bolt of lightning crashed down on the roof of a touring car and dived straight down into the car's machinery, so the report states, and followed its regular medium of conduction to the steering wheel. The driver's left hand was on the wheel, and the blow dislocated his arm at the shoulder socket; the driver managed to halt the machine and friends helped him to a nearby hospital where the dislocated shoulder was set.

Electric Fire

WE illustrate a family circle gathered around an electric grate. This grate contains some incandescent lamps (a lot of broken glass may be contained therein or other material simulating burning coal), while to produce a still more natural effect, a characteristic flickering effect is given. The heat from the lamps is caused to rotate several fans situated above the grate, below a removable top.

The imitation fuel is distributed above the fans, in the basket shaped movable top, and a flickering effect results, which is said to be very attractive.

The illustration at the left shows the grate with the basket holding the artificial fuel, swung back, so that the two fans are seen beneath it, to whose motion the flickering is due. This motion is produced by the ascending current of heated air from the electric lamps.

"What Is the Best Thing to Do in Case of a Thunder Storm If You Are Caught on an Open Highway?" First, It Is Not Good to Stop the Car Under Trees; and Owing to the Perfect Insulation of the Rubber Tires, the Machine Is Liable to Become Charged from Lightning Discharges While Running, Unless a Chain or Other Substantial Metal Connection Is Made Between the Frame of the Machine and the Ground Proper, As Shown in the Illustration—Which Will Serve to Discharge Any Electricity Set Up in the Frame or Body Direct to Earth. The Chain Need Only Be Dragged Along When Traveling During an Electric Storm.

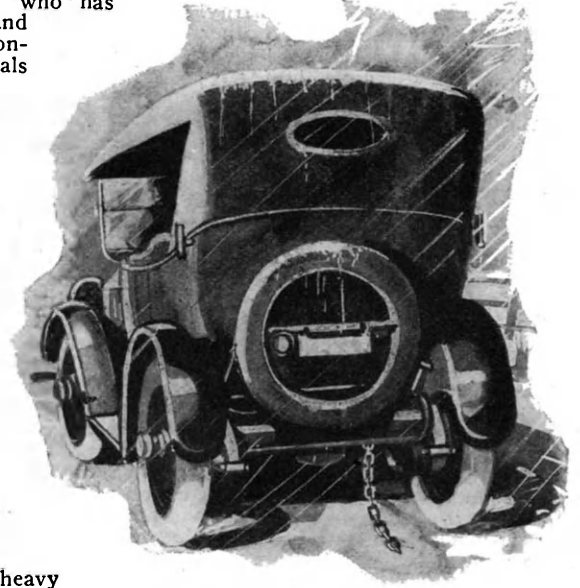

which are grounded on the main machinery and the metal chassis.

During one of the heavy thunder storms which past over New York and Coney Island,

Most people believe that they are safer in a moving automobile during a thunder storm than they would be in almost any location on the face of the earth; but this is not true from a scientific aspect, and we do not agree with the wag who explained the beauty of motoring in a thunder storm was that—you were sure to miss the lightning, as it couldn't catch up with you.

In all seriousness—it would seem a very sensible idea to ground the metal mass of the automobile body and engine during a thunder storm whether standing in the open air or in motion. This can usually be done by using a fairly heavy iron or other chain fastened to the metal work in the car, so that in the event of a thunder storm, this chain could be readily released and drag along the ground. The links of the chain, if this is used, should be not less than one-quarter inch in thickness. Another scheme might comprise a pivoted arm which could be lowered and a metal wheel mounted on the end of the arm, so as to roll along the ground.

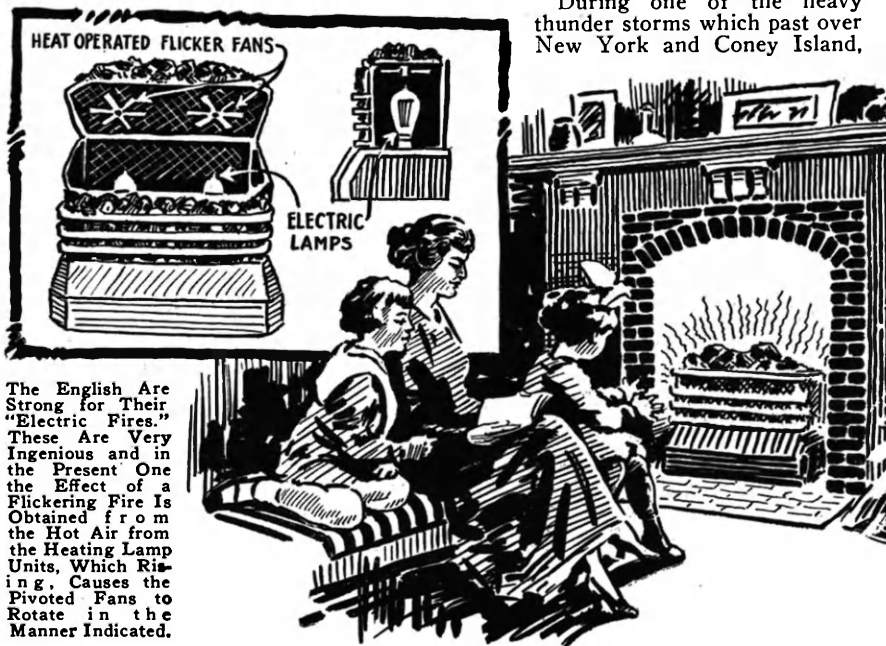

The English Are Strong for Their "Electric Fires." These Are Very Ingenious and in the Present One the Effect of a Flickering Fire Is Obtained from the Hot Air from the Heating Lamp Units, Which Rising, Causes the Pivoted Fans to Rotate in the Manner Indicated.

Forming a Single Crystal Wire

By DR. ALFRED GRADENWITZ

THE adoption of metal filaments in the manufacture of incandescent lamps meant a distinct progress with regard both to luminous intensity and the life of such lamps, there still were some disadvantages left. On one hand, the mechanical strength of the usual type of incandescent lamp filament was not fully satisfactory, and, on the other hand, there was a gradual

Microphotograph of Ordinary Filament, Showing Infinity of Crystals.

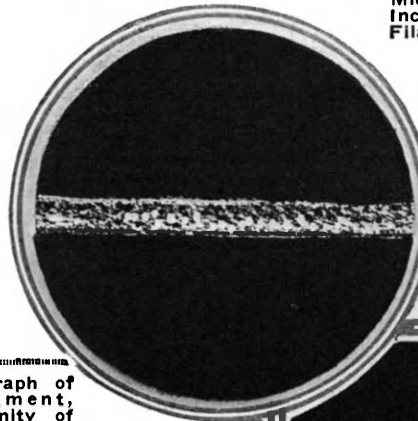

At Right:—Apparatus for Heat Treatment of Tungsten Wire.

decrease in luminous intensity on account of the progressive pulverization of the wire and the resulting deposit on the lamp walls. A firm of Berlin manufacturers has succeeded in devising a new process of making filaments of materially increased strength.

According to the processes so far in use, metal filaments were either manufactured by drawing out the wire or by compression. In either case they are made up of an infinity of minute crystals, and, inasmuch as these, at the high temperature of the incandescent filament, are liable to continual recrystallization, the structure of the filament gradually becomes rather brittle. If there were a possibility of producing a filament made up of a *single crystal* thruout its length and cross-section, any subsequent alterations in structure would, of course, be avoided. This is what the new process insures in the following manner:

If an ordinary tungsten filament be submitted to a given very high temperature, the crystal "germs" of the tungsten metal, which the filament is made up of, will exhibit a tendency to "grow" at a rate which is greater as the temperature is increased. Thus, if at a point where there

is a crystal germ an increase in temperature occurs, this germ will grow at a certain rate, and if the filament be moved thru the hot zone at a speed slightly less,

Microphotograph of Incandescent Lamp Filament Treated

According to the New Crystallizing Process. The Structure, On Bending the Filament, Is Found to Be Absolutely Uniform.

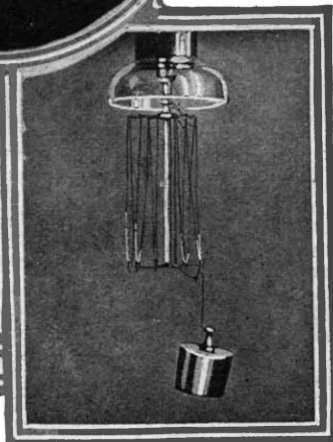
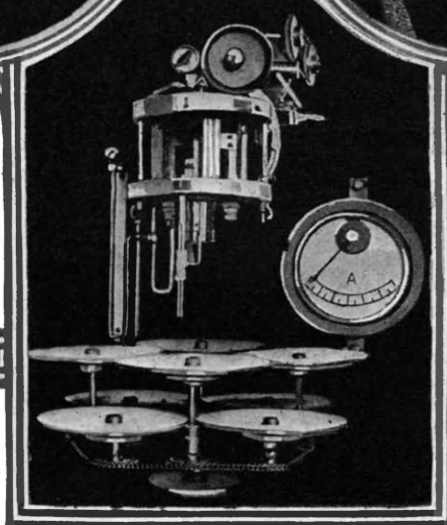
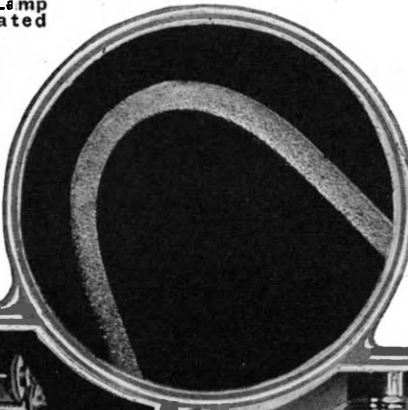

Loading Test of Incandescent Lamp Filament Treated by the New Crystallizing Process.

be converted into one single crystal thruout its length and also its cross-section.

This is how the filaments are manufactured for the new incandescent lamps. These filaments have been found to possess especially valuable characteristics, if small quantities of rare metal oxides, preferably thorium oxide, be added to the pulverized tungsten.

The extraordinary technical difficulties encountered in connection with this method have eventually been overcome by means of an apparatus both simple and ingenious. This mainly consists of a spiral of tungsten wire surrounded by a hydrogen atmosphere and which, by an electric current, is kept heated to a temperature as high as 2,400 - 2,600° C. Thru this spiral the filament to be crystallized is slowly made to pass, and is finally wound up on a coil or drum.

The incandescent lamp filament thus made is extremely flexible, its most

valuable feature being that the strength does not change when in use. In connection with one experiment the filament, after about 2,000 burning hours, could be submitted to the loading test represented in one of our figures.

It is thought possible that the same method, "spinning crystals," as it may be termed, will lend itself to the production of an homogeneous crystalline structure also in the case of other substances. Commercial science and engineering have thus been endowed with a new and most valuable industrial process.

Excessive speed of movement, of course, will cause the growth of the crystal to be stopt at a given point, as the crystals could not grow fast enough, but other crystals would be produced at other points. If, on the other hand, the proper experimental speed be maintained, the whole filament will

grow on continually. In other words, when the wire is heated sufficiently high, a portion of it will commence to "grow a crystal." If this portion is slowly moved out of the flame while another part comes into it, the crystal will extend, forming a solid fused wire.

Electrical Stethoscope for Testing Machines

You have probably seen the mechanical stethoscope which operates on a similar principle to this, used by physicians for listening to the heartbeat. This new electrical stethoscope is used by machinists as engine testers for the purpose of determining and localizing the "knocks" or other noises in engines, motors or other moving machinery.

Mr. J. Skinderviken, the inventor of the well known Skinderviken telephone microphone button, has recently perfected a very sensitive and extremely compact electrical stethoscope which is shown in the accompanying photograph. The instrument comprises a metal rod pointed at the lower end, which is placed in contact with the machine to be tested and at the upper end of this rod is mounted one of Mr. Skinderviken's microphone buttons.

Any vibrations, knocks or noise transmitted along the metal rod to the microphone button are translated into electrical currents of varying intensity which give

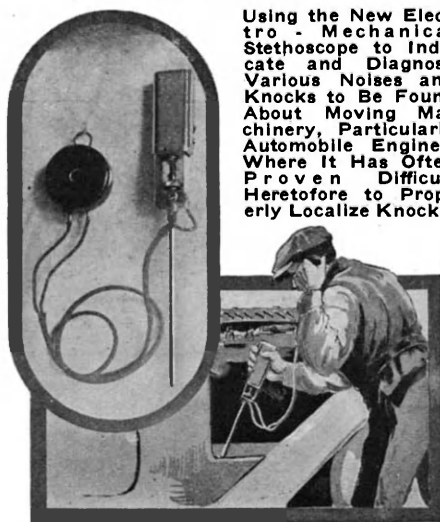

Using the New Electro-Mechanical Stethoscope to Indicate and Diagnose Various Noises and Knocks to Be Found About Moving Machinery, Particularly Automobile Engines, Where It Has Often Proven Difficult Heretofore to Properly Localize Knocks.

rise to corresponding fluctuations in sound in the 5 ohm telephone receiver connected with the flashlight battery and the transmitter button. It is surprising how sensitive this instrument really is and how slight a noise can be heard when listening thru the telephone receiver. The length of the flexible cord connecting the microphone button and the telephone receiver can be almost as long as desired, but of course, for ordinary requirements may be one about three feet long.

Owing to the clever use of the small flashlight battery and case, together with its usual sliding button switch, the entire outfit is very small and compact.

There has long been a demand for such an apparatus as the above, but heretofore no one has produced a sufficiently sensitive stethoscope at a low enough price to make it popular with those who have a use for it—viz., the machinist and auto repair man, or others having to do with steam and electrical machinery.

Nature's Fly Traps

By JAY G. HOBSON



Two of the Most Curious Plants in All Nature — the Venus Flytrap and the Trumpet Flytrap. The Trumpet Flytrap Shown at the Right of This Actual Photograph, Lies Normally in an Open Position; When a Fly Approaches and Enters the Trap or If It Is Ticked with a Piece of Grass or Straw, It Will Close up, the Teeth on Its Edge Overlapping Tightly. Mr. Fly is Devoured by a Peculiar Poisonous Soluton Secreted by the Plant. Afterward the Trap Opens Again, Ready for Another Fly.

Near the above plant I found another kind of Nature's Fly Trap. It resembled a trumpet, large at the top and small at the bottom. Above the large opening grew a fan-shaped attachment intended for insects to light upon. The underside of this unique arrangement gave off a similar lemony secretion to attract insects, but there must have been another chemical added to the solution because the very second a fly crawled underneath this attachment and ate of the liquid thereon it began to jazz around on one foot then another, and finally became so dizzy it would fall into the large opening of the trumpet plant, and on down into the small neck where very fine and stiff hairs caught it securely on all sides. The fly could climb further into the neck of the plant—but not out.

As soon as the insect came into contact with the signal hairs the liquid peculiar to the plant poured over it. By close observation I could see the liquid gradually inundate its victim and the process of dissolution in operation. Only a comparatively

WHILE camping near the coast in Carolina I chanced to find some of the most wonderful plants in the world. Plants that feel, think and taste; that have working parts like a perfect machine of mechanical construction. No man-made device can equal the operation of this singular plant. It is green in color and about four inches high. The top is the shape of a butter bean, and has two jaws with hair like teeth that open and close the instant certain spots on the surface are touched. It is the only insectivorous plant known that has operating parts like a machine.

Flies, ants and sand bugs comprise the main fare for this marvelous invention of nature. When hungry it opens its flat jaws and spreads a lemony odorless liquid over the outer edge of them to attract the insects. When a fly lights on top of the jaws they close quickly, imprisoning it. Once tightly closed the plant pours a digestive chemical over the insect which completely dissolves it. This liquid is eaten by the plant. Immediately after one fly is devoured the jaws open wide—ready for another.

To demonstrate the workings of the plant I touched these vulnerable spots with a blade of grass and immediately the jaws snap together tightly, but finding no insect within, they opened again. I repeated this test several times with the identical result, which further attests to the fact that certain plants do feel, think and taste.

When I tickled its jaws it felt the object

The Venus Flytrap Which Has Been Described Above. Here the Fly Can Be Seen Entrapped in the Plant at Fig. 2. The Illustration at Fig. 3 Shows the Famous Trumpet Flytrap; When a Fly Alights on the Top of the Overhanging Leaf, He is Eventually Precipitated or Dropt into the Open Mouth, the Bottom of Which is Coated with Hairs. These Aid in Holding the Fly and Also in Releasing the Liquid Which Drowns and Digests Him.

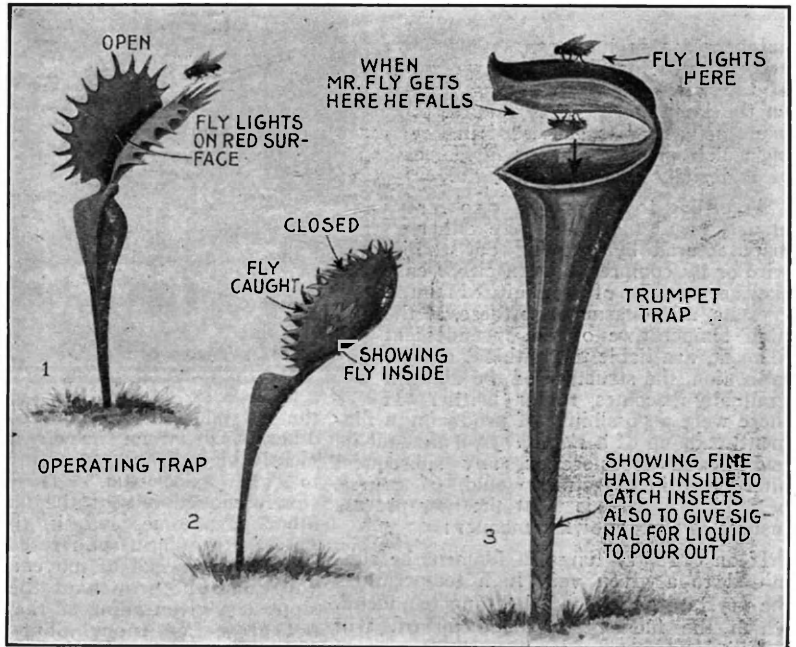

and closed them tightly. Finding nothing to taste between, it thought a mistake had been made and reopened. How else would it have known when and how to operate if it did not have at least three of the human senses?

short time was required to complete the process and about the time one fly had been thoroughly consumed, another would foolishly find its way into the death trap. These are truly two of Nature's greatest inventions. Copyright 1921, by the Author.

An Electric Motor for a Dime

With the rapidly and always-with-us H. C. L., it is not very frequent these days that we see a real bargain, especially in electrical apparatus, but recently one of the editors had the surprise of his life while passing thru one of the numerous "5-and-10-cent" stores in an eastern city.

"Ye Gods!" he almost exclaimed in his surprise, as he gazed down at the counter and beheld—what could it be? . . . Yes, it was an honest-to-goodness electric motor with magnet coils and everythin', and just to prove it, here's the photograph of the very motor which the writer saw selling for one whole dime and no war tax added! How one can find a concern which can build these fast and cheap enough so as to sell for a dime, which will hardly buy a drink of coffee or a smell of pie in Max's "Busy Bee" today, is more than we can tell. The armature of this imposing machine is

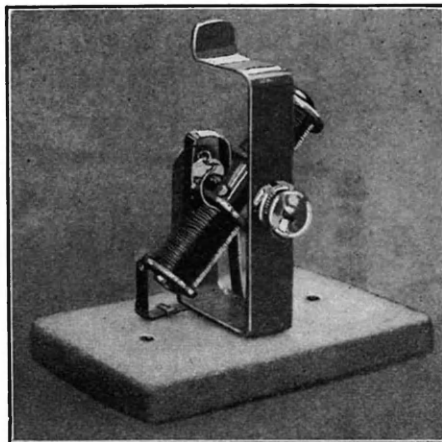

a piece of soft iron $1\frac{1}{4}$ inches long by $\frac{1}{4}$ inch in diameter, with a wire nail past thru the center of it, forming the shaft. The two armature coils comprise about four layers of No. 24 enamel magnet wire, each coil $\frac{5}{8}$ inch long. The two coils are wound in series, one end being grounded on the iron armature core and the other being tied thru a hole in the edge of a fiber disc forming the commutator, which can be seen in the photo. A spring brass brush makes contact with the commutator once in every revolution.

A single dry cell or two will run the motor at high speed, altho it may have to be started by hand. One wire connects with the iron field frame while the other battery wire connects with the insulated brass brush. This motor is of the well-known impulse type, and has a grooved wooden pulley at one end in the shaft.

Science Siftings

NEW ELECTRIC BENCH DRILL

THE new bench drilling stand illustrated here, and which has just been put on the market, takes $\frac{3}{8}$ ", $\frac{1}{2}$ ", $\frac{9}{16}$ ", $\frac{5}{8}$ " and $\frac{7}{8}$ " portable electric drills, which can be quickly and easily detached and replaced.

The bracket carrying the drills can be raised or lowered on the vertical column and is secured in any desired position by means of a split collar and clamping screw. The drill may be swung clear of the base, making it possible to use this stand for such work as applying ring gears to automobile axles, drilling holes in the ends of shafts, and doing other work on objects too high to be drilled on the table.

Both vertical and horizontal adjustments are secured by means of the clamping screw.

An extra long feed lever gives a feed ratio of 6 to 1. 100 pounds pressure applied to the handle feeds the drill under 600 pounds pressure, which means fast work with little effort.

In the base are six tapped holes to accommodate half-inch studs, used to clamp the work in place. One stud with nut and clamp is supplied with the stand.

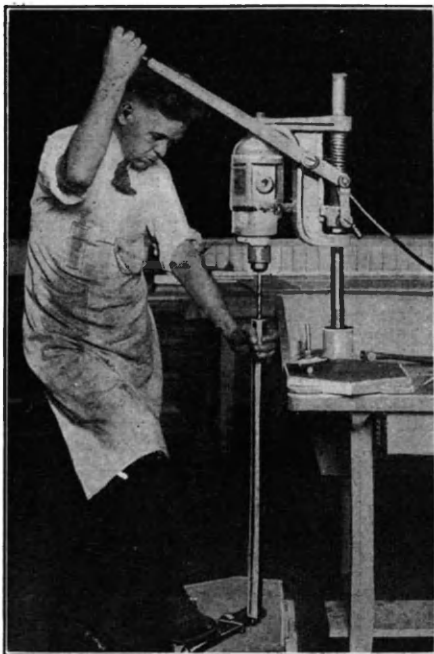

New Portable Electric Bench Drill Which Is Adapted to Boring Holes in Metal, Wood, Fiber and Other Materials From $\frac{3}{8}$ Inch Up to $\frac{7}{8}$ Inch in Diameter. Both Vertical and Horizontal Adjustments Are Possible With This Drill.

THIS BUSH BURNS BUT DOES NOT INJURE PLANT.

An interesting and unique garden plant belonging to the family of the *Rutacea* is called *Dictamnus fraxinella*. Its flowers, which Linné says are perfectly white, usually have dark red stripes upon their white petals. These flowers are never found scattered about the plant but are always restricted in clusters or thick bunches. This beautiful shrub has the peculiar common name of the "gas plant," which is by no means a misnomer.

In a sunny spot this plant will grow luxuriantly if the soil is rich and well cultivated and not kept too damp. Then it attains a height of three feet. The leaves which are thick and glossy, give off a lemonlike odor when they are rubbed. This plant can be propagated either from seeds or by slips. If the former method is used the seeds should be sown when they are ripe and protected against the winter frost.



One of the Most Wonderful Plants in the World!—Known Commonly As the Gas Plant. The Leaves Secrete a Volatile Oil and Can Be Ignited with a Match. The Oil May Burn, But the Plant Will Not Be Injured by the Flames.

The plant is covered with numerous brown gland-like formations which, especially in warm weather, secrete a volatile oil. This can be easily ignited with a match if it is held beneath the plant. To see the volatile oil flare up brightly is an interesting and startling phenomenon, which does not injure the plant in any way whatsoever.

MAGNETIZED PULLEYS AND STEEL BELTS.

The use of thin steel or iron belts on magnetized pulleys has been patented in France to transmit power. The steel pulleys are magnetized by windings lying in helicoidal slots on the surface of the pulleys, as here illustrated. The thickness of the belt does not usually exceed 0.06 times the diameter of the smallest pulley. With a steel belt of $\frac{1}{6}$ inch thickness making contact over an arc of 145 degrees, on a pulley of 10 inches diameter running at 4,000 revolutions per minute, it is possible to transmit more than 200 horsepower per

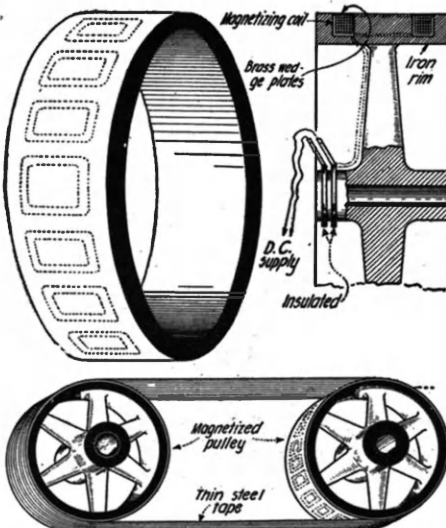

A Clever French Conceit Is This Latest Magnetized Steel Pulley and Belt. Steel "Belt" Wires Are Held Tightly to the Pulley by Magnetic Windings in the Faces of the Pulleys Themselves, as Shown in the Section Diagram.

inch width of belt, reports state. With a pulley of 50 inches diameter running at 800 revolutions per minute, a belt of 1 inch width will transmit 1,000 horsepower. Steel belts may be run at speeds of 18,000 feet per minute so that this method of transmission is suitable for speed reduction with turbines. It is really remarkable that some genius did not concoct such a scheme before, particularly as it is the centrifugal force effect or flying out of ordinary leather belts that limits their safe operating velocity. About 5,000 feet per minute is the limit of belt speed ordinarily, the belt transmitting less and less power as the velocity is increased above that figure.

KNOTTED STRING SENDS MESSAGES.

During the war, the antagonistic powers had very clever range finders, the same in principle and design practically, as those used by the Allies, whereby they could locate with great exactness the radio transmitting station on any portion of the front.

For this reason, ways had to be determined, whereby either the location of the transmitting stations would be concealed or clever decoys used. One of the simplest decoys is the device shown in the photograph. This method consisted of having a small

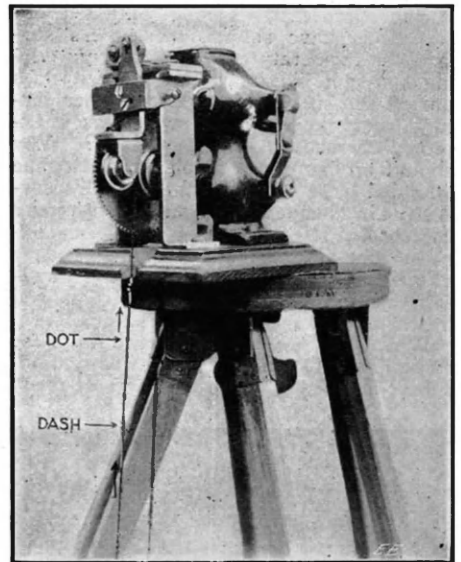

A Clever and Very Simple Code-Teaching Instrument Formed by a String With Knots Tied into It, These Knots Passing Between the Two Rollers and Serving to Open and Close the Electric Buzzer or Other Circuit. The Battery Motor Shown Rotates the Friction Wheels Which Pull the Cord Upward Between Them.

battery motor capable of operating on one or two cells, pull on endless tape or cord; into this cord were tied tiny knots—three knots together, constituting a dash and one knot, a dot. The motor driving this cord would pass the same between a spring-like contact, and a very clever omnigraph or automatic sending device was the result. Clockwork mechanism (an alarm clock) was then arranged to set off the transmitter at the desired time. Its effect was very startling.

A fake coded message was tied into the cord, stating that a certain sector is to lay down a barrage and then charge across No Man's Land. A buzzer transmitter also operated on batteries was used and the aerial concealed in a camouflaged tree. In order to make it seem that a distant transmitting station was being employed, a piece of potato was arranged across the contacts, so that the make-and-break was not sharp, resulting in a sound very much like a powerful wireless station at a considerable distance.

Popular Astronomy

By ISABEL M. LEWIS, M. A.

of U. S. Naval Observatory

SUN-SPOTS are one of the signs of unusual solar activity. These cyclonic storms in the photosphere of the sun are attended by an increase in the solar energy of radiation.

When spots are most prevalent eruptive prominences are most frequent and violent, the solar corona is most brilliant and extensive, the solar atmosphere is most perturbed and vapor-laden and magnetic storms and auroral displays in the atmosphere of the earth are of most frequent occurrence. The solar constant of radiation,—which is the amount of energy delivered at the earth's outer atmosphere per square centimeter per minute at right angles to the solar beam at the earth's mean distance from the sun,—averages higher during sun-spot maxima years than it does during sun-spot minima years. In consideration of this fact we would naturally expect to find the general surface air temperature of the earth higher during sun-spot maxima years than during sun-spot minima years. This is not so, however. Quite the contrary, in mid-latitudes at least, as long-continued observations have shown, the earth's surface air temperature averages *lower* during sun-spot maxima years than it does during sun-spot minima years—other factors being the same. How is this unexpected correlation to be explained? Why should an increase of solar radiation be attended by a decrease of the earth's surface air temperature and vice-versa? Meteorologists and solar physicists explain this anomaly as due to secondary effects brought about in the earth's atmosphere and in the solar atmosphere as well by changes in the intensity of radiation.

When spots are most frequent and solar radiation most intense the solar atmosphere is laden with the vapors of many

Sun Spots and the Weather

elements and is abnormally dense and turbid. Consequently, the radiations of shorter wave lengths, the violet and ultra-violet radiations, are more effectively entrapped by it. During sun-spot maxima periods, then, there is less radiation of violet and ultra-violet light from the sun than during sun-spot minima years when the solar atmosphere is comparatively clear. Now the violet and ultra-violet radiations of the sun produce important changes in the earth's upper atmosphere. The passage of these radiations of short wave-length through the cold, dry oxygen in the upper atmosphere of the earth tends to convert this oxygen into ozone, which resembles water vapor and carbon dioxide in its ability to absorb the heat rays that are radiated from the surface of the earth and from its lower atmosphere. An excess of ozone in the air, therefore, has the effect of increasing the temperature of the earth's atmosphere by absorbing the radiation of heat waves from the earth. Ozone is far more absorptive of earth heat radiations than it is of the incoming solar radiations and as a result the net effect is to *raise* the temperature of the air at sun-spot minima periods when the escape of short wave-length radiations from the sun is greatest. There is also another secondary effect set up in the earth's atmosphere by changes in the intensity of solar radiation, that operates to produce a *lowering* of the temperature of the earth's surface air during sun-spot maxima periods.

When the solar radiations are most intense, that is, when sun-spots are most

prevalent, electrified particles are shot off from the solar surface with greater intensity than under normal conditions. These electrified particles penetrate to greater depths in the earth's atmosphere during sun-spot maxima periods and produce the auroral displays that are most prevalent then. Now the electrical discharges in the earth's upper atmosphere which cause the auroral displays generate nitrous oxide and other compounds that, owing to their density, drop to lower levels and become the nuclei for the formation of cloud particles of cirrus and cirrus haze, the highest of all clouds. During sun-spot maxima periods, then, cirrus and cirrus haze form more frequently than at any other time and owing to the size of the particles of which these clouds are formed they are more effective in shutting out the incoming solar radiations than they are in preventing the escape of the longer wave-length earth radiations. Consequently their presence tends to *lower* the surface air temperature of the earth during sun-spot maxima years—other factors being the same.

There are two causes operative, then, one during sun-spot minima periods, and the other during sun-spot maxima periods, that produce opposite effects upon the temperature of the air. The increase of ultra-violet radiations during sun-spot minima years tends to increase the amount of ozone in the air and consequently to *raise* the temperature of the air during these years and the increase in the amount of cloudiness in the sun-spot maxima years due to excess of electric discharges in the upper atmosphere tends to *decrease* the temperature of the air during sun-spot maxima years by shutting out more of the solar radiation than usual.

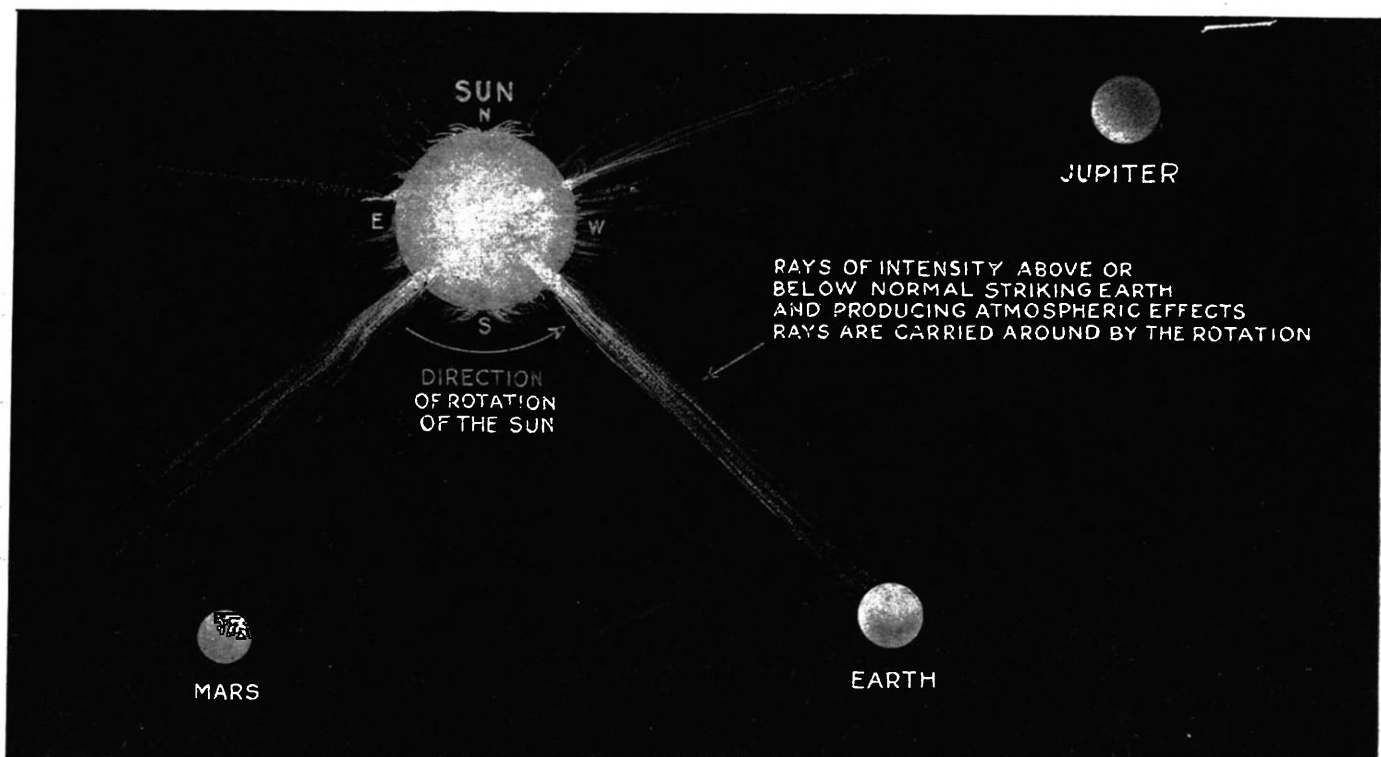

© 1921 by Science & Invention

The Illustration Shows Rays of Different Intensities Coming From Restricted Areas of the Solar Surface, Rotating With the Sun Like the Spokes of a Wheel, and So Falling Upon Different Planets in Turn Thus Producing Changes in Their Atmospheric Temperatures.

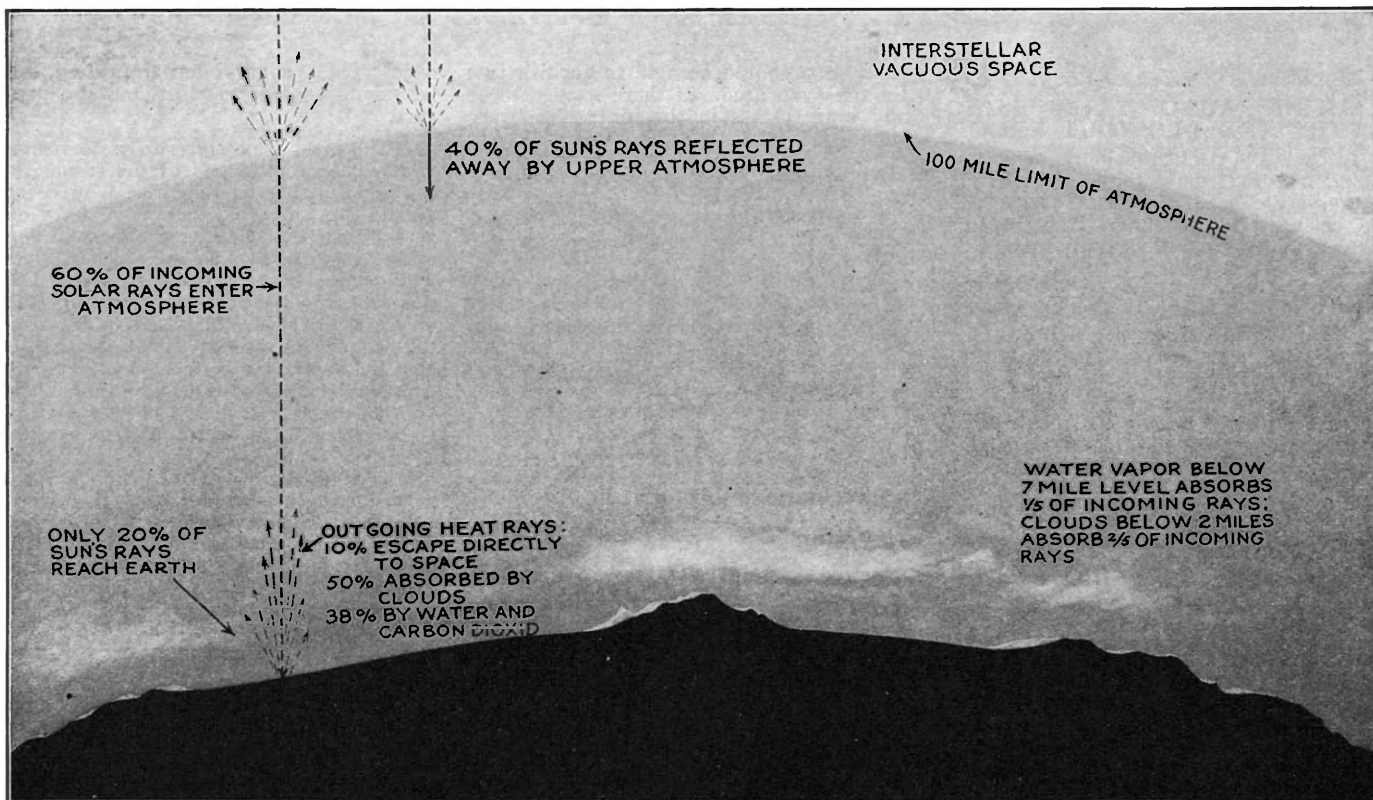

© 1921 by Science and Invention

Forty Per Cent of the Solar Rays Reaching the Earth's Outer Atmosphere Are Reflected Thereby, and Have No Effect On the Earth Or On Its Atmosphere. Of Sixty Per Cent of the Solar Rays Which Enter the Atmosphere About Twenty Per Cent Are Directly Absorbed By Land and Water Surface; of the Rest One-Fifth Is Absorbed By Water Vapor Within Seven Miles of the Earth's Surface and Two-fifths By Clouds Within Two Miles Thereof. Of Radiations from the Earth's Surface About Ten Per Cent Escapes Directly Into Space; About Half of the Outgoing Radiation Is Absorbed By Clouds and Three-fourths of the Remainder By Water Vapor and Carbon Dioxid in the Atmosphere. After Successive Radiations from Place to Place the Heat Thus Absorbed By the Atmosphere Gradually Escapes to Space. The Atmosphere Acts As a Screen in Cutting Off from the Earth 80% of Incoming Solar Rays and in Absorbing 90% of Outgoing Earth Rays.

It is not known positively that these are the sole causes or even the chief causes in producing the known periodic changes of temperature during the spot cycle, but they offer a very plausible explanation of the observed temperature differences. It must be borne in mind, moreover, that they are by no means the only causes operative in changing the average surface air temperature and their effect is often masked by other disturbing factors.

Prof. W. J. Humphreys of the U. S. Weather Bureau has shown convincingly in his "Physics of the Air" that volcanic dust thrown into the earth's upper atmosphere is a far more potent factor in its effect upon the temperature of the air than either of these two causes and its presence in considerable quantities in sun-spot minimum years may overbalance the effect of increased ultra-violet radiations and cause such years to be abnormally cold instead of warmer than the average. Volcanic dust in the upper atmosphere, Prof. Humphreys shows, is fully thirty times more effective in shutting out solar radiations than it is in retarding the longer wave-length earth radiations. It acts as a screen in reflecting away to space the incoming solar radiations of short wave length while offering little obstruction to outgoing earth radiations and so its effect is always to lower the temperature of the air. Only volcanic eruptions powerful enough to throw this dust to great atmospheric heights produce this temperature effect, however, such as the eruption of Krakatoa in 1883 and of Katmai in 1912. The latter eruption occurred at the time of the last sun-spot minimum and made this period abnormally cold instead of warmer than the preceding sun-spot maximum period as would have been expected under normal conditions. The greatest temperature effect of volcanic dust frequently lags by a period of a year or more after the eruption.

The usual temperature difference between a sun-spot maximum and a sun-spot minimum period averages from 0.5° C. to 1.0° C. This may seem to be a quite negligible difference but Prof. Humphreys shows that it has a very practical effect upon the production of crops and upon the time required for crop production, since an increase of only 0.5° C. in the earth's average surface air temperature shifts the isothermal lines eighty miles north in the northern hemisphere or south in the southern hemisphere. It is of practical value, then, to know in advance what temperature changes are to be expected during sun-spot maxima and sun-spot minima periods.

The Astrophysical Observatory of the Smithsonian Institute under the directorship of Dr. C. G. Abbot has been carrying on for a number of years continuous observations of the value of the solar constant of radiation at several widely separated stations established for this sole purpose. Observations were first started in Washington in 1902. A large drop in the value of the solar constant of radiation amounting to nearly ten per cent was observed in the spring of 1903 and as the new values continued it was suspected that an actual variation in the output of solar energy had taken place. It was also noted that this great and sudden drop in solar radiation was followed by a universal temperature change in the north temperate zone.

It was this marked correlation between solar radiation and temperature changes that led to the undertaking of systematic observations of the value of the solar constant of radiation by the Smithsonian Institute with remarkable results. A station was established on Mt. Wilson, California, for this purpose and nearly simultaneous observations of solar radiation were obtained on Mt. Wilson and at Washington, D. C. Later nearly simultaneous observations were made at Mt. Wilson and at

Bassour, Algeria, where a station was temporarily established. Though the stations were separated by a third of the circumference of the world the same variations in the solar constant were obtained at both stations, showing that the variations lay in the sun itself and were not to be accounted for by changes in the earth's atmosphere or by errors of observation.

In 1918 the Smithsonian Institute established a station at Calama, Chile, which is supposed to be one of the most cloudless regions on earth. This station has recently been removed to a still more favorable station at Montezuma, Chile, ten miles distant. The station on Mt. Wilson has also been abandoned recently in favor of a station in the Harqua Hala Mountains in Arizona. Daily observations of the solar constant of radiation are being made at the stations in Chile and Arizona and at the Astrophysical Observatory in Washington. Of such practical importance is this work believed to be that it is only for lack of funds that the Smithsonian Institute has not established additional stations in widely separated parts of the world.

As a result of the long series of observations that have been made by this Institution since 1902 it has been established beyond a doubt that the radiation of the sun is variable and of a two-fold nature and that its variations are followed by important terrestrial atmospheric effects such as marked changes in temperature, rainfall and pressure.

It has been found that in addition to the long period variations in solar radiation which accompanies the sun-spot cycle, averaging eleven years in length and with a range of from three to five per cent in value there are irregular variations having periods of a few days, weeks or months, that are at times more marked than the longer period variation, their

(Continued on page 93)

MOTOR HINTS

First Prize, \$25.00 MAKING AUTO TIRES PUNCTURE AND BLOWOUT PROOF

In using old tires to make reliners, nearly all motorists make the mistake of cutting off the bead and tread of the shoe to be used as a reliner. This cutting process leaves rough edges that chafe the inner tube and otherwise so weakens the tire that it is rendered even less efficient than the conventional purchased reliner.

It is not generally known that a regular sized shoe will fit perfectly inside the over size shoe for the same rim without any cutting or alteration whatever. In selecting tires to be mounted in this way, to get the very best results, it is well to select for the inner shoe, one that will withstand the necessary air pressure without the reinforcement of the outer shoe. The condition of the tread is of little importance since this shoe does not come in contact with the road. The outer shoe can be in any condition, except, of course for longer wear it is essential that the tread be in fair shape. Any well stocked

junk shop should be able to furnish just the tires you need. If there happen to be any weak places in the inner shoe, care should be taken to place them so that

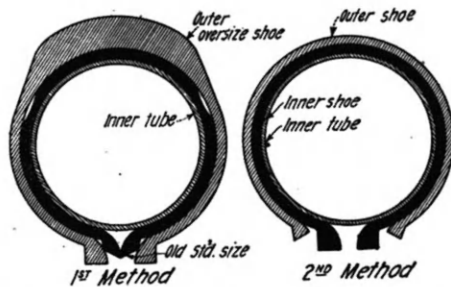

Doubling the Life of Your "Shoes" By Using An Old Shoe Inside or Outside of the New Shoe.

they will be reinforced by a good section of the outer shoe. When shoes are mounted in this way, they are immune from all ordinary punctures, due to their thickness. They can not blow out for when the outer shoes does finally wear thru, the inner shoe, which does not wear

except for a slight internal friction, will be strong enough to withstand the pressure.

If the inner shoe starts to weaken first, you will be forewarned of the trouble by a slight bulging of the tire. The defect should be remedied before a blow-out actually occurs. The inner shoe will generally outwear two or three outer shoes. The writer has used shoes mounted in this way for six years frequently getting from ten to twelve thousand miles from tires that were considered too weak to be repaired, which is better than some new tires will do. It is well to remember that you must use like tires for a pair; that is, a cord with a cord and a fabric with a fabric. Since cord tires are larger than fabric, a regular cord tire is too large to fit inside an oversized fabric, also a regular sized fabric will fit too loosely inside an oversized cord. These double tires go on the rim almost as easily as a single tire and prove equally as satisfactory with clincher tires as with straight side.

Contributed by H. C. ROWELL.

Second Prize, \$15.00 AIR PUMP EMPTIES "GAS" TANK ON HILLS

As known, cars having a gravity gas feed with the tank under the seat, will often stall in midhill because of the gas

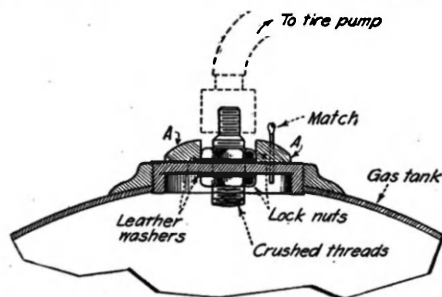

Pumping Air Into the Gasoline Tank, When On a Hill, Will Keep the Engine Going if the Gas Is Low.

level being below the carburetor. This device will make your car go as long as there is any gasoline in the tank.

An ordinary tire valve is screwed into a hole in the cap, of the gas tank, which is drilled to fit it. Two lock nuts are screwed on, with leather washers between. The thread below the lower nut are upset to prevent the nipple from coming off. The flanges (a), for loosening and tightening cap, will have to be filed to permit the lock nut to seat.

When stalled all that is necessary is to attach pump and compress the air in the tank which will drive the gasoline to the carburetor.

A match may be used to plug the small air inlet in the cap so as to prevent any air from escaping.

When once attached this device is always ready for an emergency.

Contributed by JONAS BYBERG.

"TICKLING" THE ENGINE FOR STARTING.

A double contact key is connected into the ignition circuit as shown in the diagram. The internal connections of the breaker and coil are shown so the idea can be adopted to any battery system. It will be apparent that after the ignition is switched on it is possible to cause a spark

\$50.00 IN PRIZES

Paid for "Motor Hints."

Most of our readers have a car of their own, and any number of them have made certain improvements on that car. We want to know about these improvements. What we want are PRACTICAL ideas, not freak stunts. The idea should be simple enough, so that anyone handy with tools can duplicate it. Note that the idea does not necessarily have to be electrical in any way.

We would like to have a photograph of the stunt showing that it was actually tried, but this is not absolutely necessary to win a prize. A simple sketch will do showing the essential parts, etc.

We will pay the following prizes each month:

FIRST PRIZE.....	\$25.00
SECOND PRIZE.....	15.00
THIRD PRIZE.....	10.00

All other accepted articles, which win no prizes, will be paid for at the rate of \$2.00. Articles submitted should not be long ones. About one hundred to two hundred words will suffice. Address all manuscripts to Editor, "Motor Hints," care of this publication.

in the cylinder nearest the compression point by operating the key. Should the breaker be closed, depressing the key will open the primary circuit and give a spark. Should the breaker be open the key will close the circuit thru the coil and on opening give a spark.

When shutting off the engine speed it up

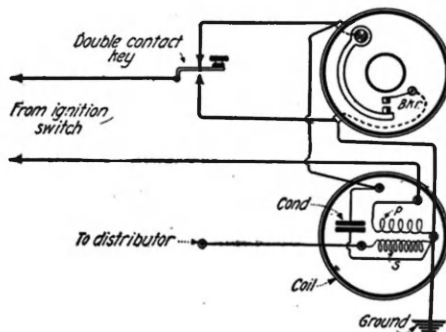

This "Tickler" Ignition Circuit Will Save Using the Self-Starters Many Times, and Prolong Life of Storage Battery.

Third Prize, \$10.00 GASOLINE CLEANING BRUSH

Here is a combination scrubbing brush and gasoline sprinkler for cleaning purposes that will save a lot of unnecessary motions and much time. In the back of

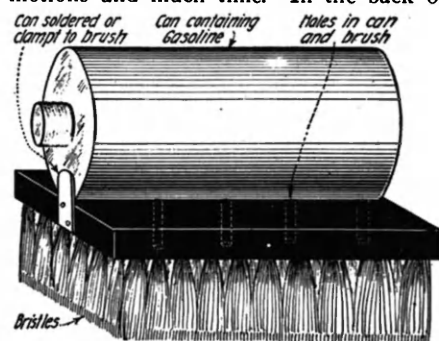

Clever Gasoline Cleaning Brush Made By Fixing a Can to the Brush in the Manner Illustrated.

an ordinary brush of the better type a number of small holes are drilled. These penetrate all the way thru the back of the brush and act as guides to wet the bristles with gasoline. Next a small can which will be filled with gasoline is attached by soldering or clamping to the back of the brush. One of several small holes can be drilled in this can to let the gasoline flow into the back of the brush and so down thru the other holes to the bristles of the brush. The can as shown in the sketch acts as the handle for the device. This brush will be found useful in any garage wherever scrubbing or cleaning with gasoline or other liquids is necessary.

Contributed by PAUL H. KOENIG.

for an instant, cut off the ignition and open the throttle wide. This results in charges of unburnt gas being drawn into the cylinders. When about to start the key is operated, the sparks in the cylinder will explode the gas and start the engine if it has stopt with the piston in the proper place. This method of starting works nearly every time on short stops, but the writer has "kicked over" an engine by this method after standing over night. Contributed by THOMAS W. BENSON.

Home Mechanics

Conducted by WILLIAM M. BUTTERFIELD

CONVERTIBLE PORCH SCREEN.

A hanging porch screen formed of three panels hinged together in the customary manner, is illustrated in the accompanying figure. Each panel is formed of a two-inch frame, twenty-nine inches wide, and as long as is desired, made of wood and joined

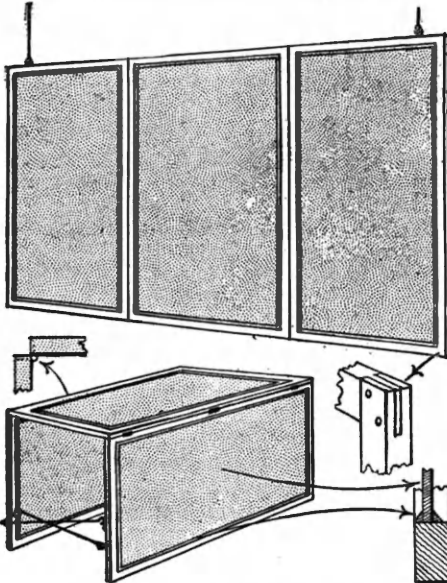

Porch Screen Made of Wall-Board Supported On Light Wood Frames. The Wall-Board Should Be Painted. Folded It Serves As a Table.

at the corners by mortises. These frames are filled with common wall-board, held in place by ordinary one-half inch wood moulding (quarter rounds) are available, bradded to the frames as demonstrated in the figure. Three hinges are used for connecting each panel to the other—all let into the wood to insure a close joint when the screen is open. Thin rods with hook ends are fastened to the screen, with screw-eyes, and suspend the screen by hooking into screw-eyes in the ceiling of the porch. For utilization as a table, the screen can be folded in the form of a porch table, thus serving a two-fold purpose as a porch accessory, the rods holding the table in shape by hooking into screw-eyes in the side panels.

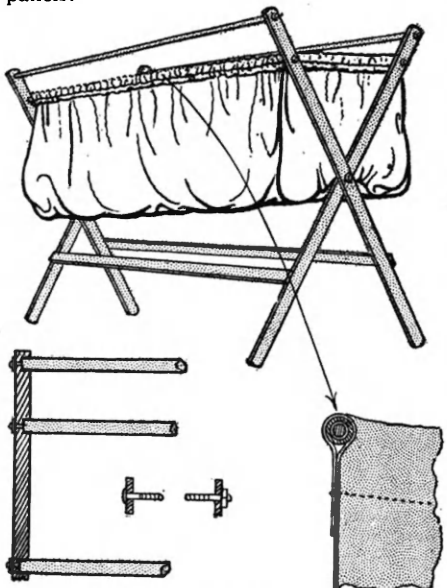

Collapsible Work-Bag Made of Any Desirable Cloth Hung on a Supporting Frame of the Type Illustrated.

COLLAPSIBLE WORK-BAG.

A very popular form of work-bag with the ladies just at present, is that here shown. It consists of a cloth bag of any desired shade and figure suspended within a wood frame that can be folded camp-stool or hand-bag fashion and carried by handles that close together. Like the hand-bag these contrivances are of all shapes and sizes, therefore the figure is in a sense suggestive of what can be easily accomplished by a home mechanic, rather than a definite plan to scale for work-bags in general.

The frame shown consists of two X-shaped folding ends of smooth strips of rectangular section, held together by screws and round rods. The ends of the rods are countersunk half way thru the rectangular strips as shown and secured by screws and washers. Two wood cleats connect the lower ends of the frames. The bag is strung curtain-pole fashion on two of the rods and folds when the frame is closed. Dowel sticks are admirable material for use in making this work-bag.

CEDAR-OIL BOX

For the purpose of converting each clothes closet in the house into an efficient cedar chest, proof against moths, a box-like drawer, large enough to hold a three-inch white glass (porcelain) cup such as is used for shoe polish or salve—is made and perforated on four sides in the manner shown. This drawer is suspended from a convenient shelf by an arrangement consisting of a drawer cover of one-half inch board, forming flanges at two sides and also acting as a stop at the back, so as to give a one-half inch clear space between the rear of the drawer and the skirt of frame of the drawer, and of a frame constructed and fastened to the shelf in the manner shown.

The cup, of course, contains the cedar oil, the fumes of which pass out of its perforated tin screw top into the drawer, and from the drawer into the closet.

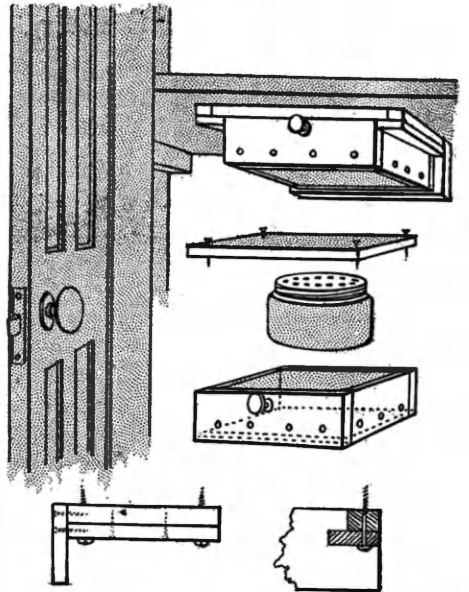

A Cedar-Oil Box for the Clothes Closet. It Is Made in the Form of a Drawer So That the Oil Container Cannot Easily Be Upset Over the Clothes.

KITCHEN IMPLEMENT RACK.

Most housewives have a difficult time making certain of their kitchen implements stay put, if hung on ordinary nails in the closet. About a half dozen of the collection fall at the least provocation, causing an unnecessary flow of "housewife profanity," besides a new washing of said implements. This "botheration" may be saved by a device easily constructed by the home mechanic and shown below.

The apparatus consists of a round-ended shelf and bracket containing eight slotted holes to hold the offending half dozen, with a duplicate or two thrown in for good measure. The shelf is one-half inch thick, six inches wide, and nine inches long; the holes about one inch and the slots one-half inch wide. Holes can be bored in such a piece without splitting out by tacking two pieces of wood together, the lower piece being discarded when the holes are bored.

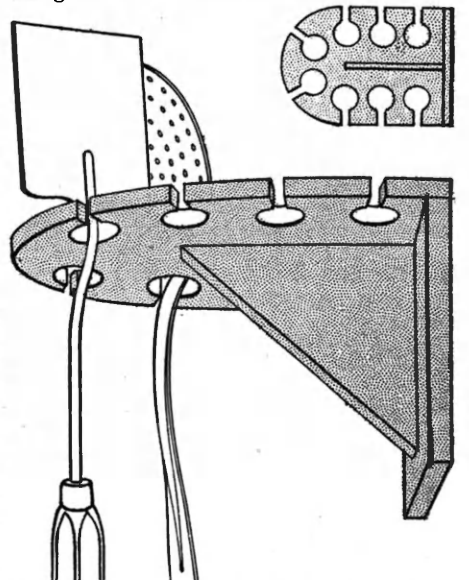

A Rack Designed to Hold the Smaller Kitchen Cooking Utensils Such As Spoons, Forks, Etc.

IMPORTANT:

TO NEWSSTAND READERS

IN order to eliminate all waste and unsold copies it becomes necessary, beginning with this month, to supply newsstand dealers only with the actual number of copies for which they have orders. This makes it necessary to place an order with your newsdealer, asking him to reserve a copy for you every month. Otherwise he will not be able to supply your copy. For your convenience, we are appending herewith a blank which we ask you to be good enough to fill in and hand to your newsdealer. He will then be in a position to supply copies to you regularly every month. If you are interested in receiving your copy every month, do not fail to sign this blank. It costs you nothing to do so.

To....., Newsdealer

Address

Please reserve for me
copies of **SCIENCE & INVENTION** every month until I notify you otherwise, and greatly oblige

Name

Address

Home Electrics

By G. L. HOADLEY, M. E.

THE cost of properly lighting a dwelling has been greatly reduced in the last few years. This is due largely to the introduction of the Tungsten filament lamp.

Computing the Cost of Domestic Lighting

crease in temperature the light is increased eleven per cent. The limiting temperature is the melting point of tungsten, but in commercial practise the filament is operated at a temperature considerably below

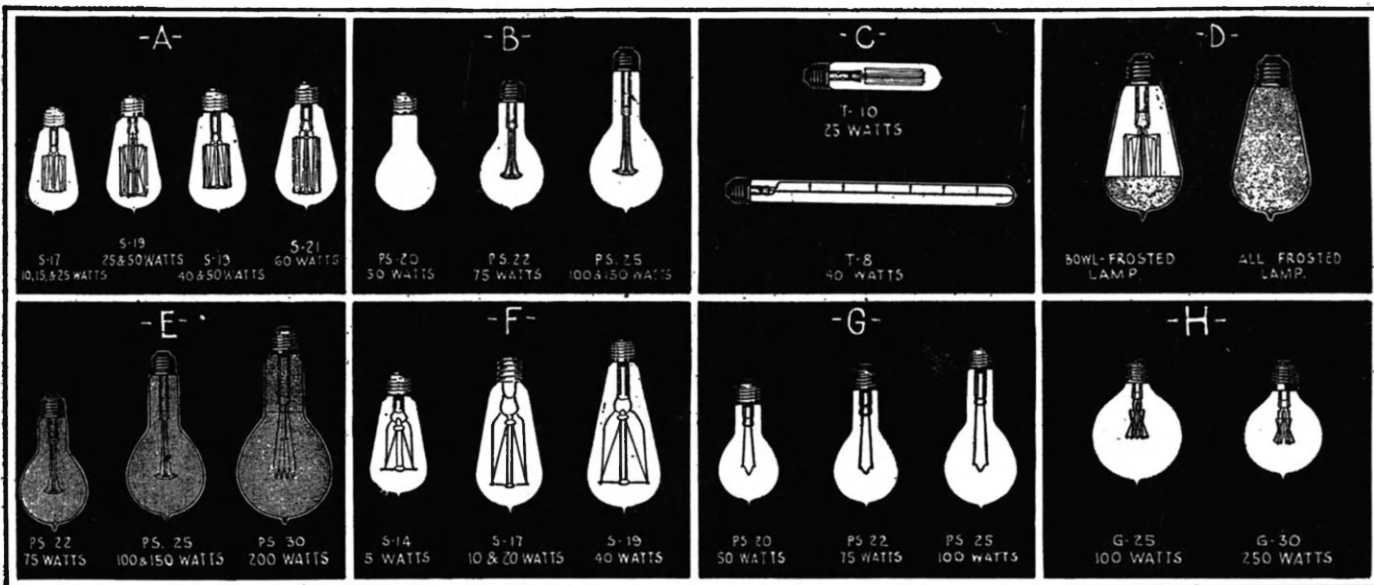

Fig. A, Shows Mazda B Lamps for 110 to 125 Volt Standard Lighting Service. B, Shows Mazda Type C or Gas Filled Lamps for 110 to 125 Volt Service. C, Illustrates Mazda B Lamps for Ornamental 110 to 125 Volt Lighting Service. D, Shows Two Types of Frosted Lamps. E, Shows Mazda "Daylight" Lamps, the Bulbs Being Made of Blue Glass to Produce a Light Similar to Daylight. F, Illustrates Mazda B Lamps for Use With Country Home Lighting Outfits of 28 to 32 Volts Potential. G, Shows Mazda C Lamps for Use On 28 to 32 Volt Country Home Lighting Outfits. H, Illustrates Mazda C Lamps Having Concentrated Filament, High Candle-Power Lamps for Stereopticon and Home "Movie" Projector Service.

This type of lamp in sizes of 10 to 60 watts or larger, glows in a vacuum just as did the old carbon lamp, for the same amount of power. The Mazda "C" lamp is gas-filled and gives out 4 to 5 times the amount of light the old carbon lamp gave. Credit for the modern Mazda lamp is due to the Research Laboratories of the General Electric Co., whose engineers discovered the way to make Tungsten ductile; that is, how to draw it into wire. Previous to this discovery, Tungsten lamps were manufactured and sold, but they were too delicate to withstand any jar or vibration, altho they were very efficient as compared to the old carbon type of lamp. The original Tungsten filament was made by mixing the Tungsten powder with a binder and then squirting it thru diamond dies, thus forming a thread which was reduced to pure Tungsten by burning out the binder. The modern filament is made by compressing Tungsten powder in a metal mould till the particles stick together and then nearly melting it by sending an electric current thru it; the billet thus formed is forged into a long wire about the size of a lead in a pencil. This wire is then repeatedly drawn thru diamond dies smaller and smaller in size, to the following diameters:

	watts	volts	of 1 inch
Mazda B.....	25	110	1.16
Mazda B.....	50	110	1.82
Mazda C.....	500	110	7.92
Carbon.....	50	110	4.00

When you stop to consider the ordinary human hair is 3.00 thousandths of an inch in diameter, you will obtain some idea of the smallness of these filaments.

The size of the filament controls in a large measure, the current flowing thru the lamp and accordingly the temperature of the filament. The light emitted depends on the temperature of the filament, the higher the temperature the greater the light emitted. For every one per cent in-

crease in temperature the light is increased eleven per cent. The limiting temperature is the melting point of tungsten, but in commercial practise the filament is operated at a temperature considerably below the melting point to prevent evaporation of the filament and prolong its life. Evaporation occurs at 2,150 degrees C. for tungsten, 1,900 degrees C. for carbon. Hence the Mazda lamp can operate at a higher temperature than the old carbon lamp and will give off a correspondingly greater light for the same amount of current used. Gas-filled lamps can operate at higher temperatures than the vacuum type lamps as the gas retards the evaporation of the filament thus prolonging its life. Consequently the gas-filled lamp is the more efficient type of lamp.

It is interesting to note that only 1 1/2 to 2 1/2 per cent of the energy consumed by the Mazda lamp is transformed into light. The balance (97 1/2 to 98 1/2 per cent) is wasted in heat. Only one-half of one per cent of the energy of a carbon lamp is transformed into light. Heat losses in Mazda C gas-filled lamps are greater than in the Mazda B vacuum lamps because any gas will conduct heat better than a vacuum and convection also cools the filament. However, these heat losses are cut down considerably by first selecting an inert gas of low conductivity, secondly, by shaping the filament so it presents as small a surface as possible to the circulating gas. The thick (Continued on page 67)

TABLE SHOWING COST PER HOUR OF CURRENT CONSUMED AT RATES FROM 1c TO 10c PER KILOWATT HOUR

Watts Consumed	RATE PER KILOWATT HOUR IN CENTS																			
	.01	.01 1/4	.02	.02 1/4	.03	.03 1/4	.04	.04 1/4	.05	.06	.06 1/4	.07	.07 1/4	.08	.08 1/4	.09	.09 1/4	.10		
1	.00001	.000015	.00002	.000025	.00003	.000035	.00004	.000045	.00005	.000055	.00006	.000065	.00007	.000075	.00008	.000085	.00009	.000095	.0001	
2	.00002	.00003	.00004	.00005	.00006	.00007	.00008	.00009	.0001	.00011	.00012	.00013	.00014	.00015	.00016	.00017	.00018	.00019	.0002	
3	.00003	.000045	.00006	.000075	.00009	.000105	.00012	.000135	.00015	.000165	.00018	.000195	.00021	.000225	.00024	.000255	.00027	.000285	.0003	
4	.00004	.00006	.00008	.0001	.00012	.00014	.00016	.00018	.0002	.00022	.00024	.00026	.00028	.0003	.00032	.00034	.00036	.00038	.0004	
5	.00005	.000075	.0001	.000125	.00015	.000175	.0002	.000225	.00025	.000275	.0003	.000325	.00035	.000375	.0004	.000425	.00045	.000475	.0005	
6	.00006	.00009	.00012	.00015	.00018	.00021	.00024	.00027	.0003	.00033	.00036	.00039	.00042	.00045	.00048	.00051	.00054	.00057	.0006	
7	.00007	.000105	.00014	.000175	.00021	.000245	.00028	.000315	.00035	.000385	.00042	.000455	.00049	.000525	.00056	.000595	.00063	.000665	.0007	
8	.00008	.00012	.00016	.0002	.00024	.00028	.00032	.00036	.0004	.00044	.00048	.00052	.00056	.0006	.00064	.00068	.00072	.00076	.0008	
9	.00009	.000135	.00018	.000225	.00027	.000315	.00036	.000405	.00045	.000495	.00054	.000585	.00063	.000675	.00072	.000765	.00081	.000855	.0009	
10	.0001	.00015	.0002	.00025	.0003	.00035	.0004	.00045	.0005	.00055	.0006	.00065	.0007	.00075	.0008	.00085	.0009	.00095	.001	
11	.00011	.000165	.00022	.000275	.00033	.000385	.00044	.000495	.00055	.000605	.00066	.000715	.00077	.000825	.00088	.000935	.00099	.001045	.0011	
12	.00012	.00018	.00024	.0003	.00036	.00042	.00048	.00054	.0006	.00066	.00072	.00078	.00084	.0009	.00096	.00102	.00108	.00114	.0012	
13	.00013	.000195	.00026	.000325	.00039	.000455	.00052	.000585	.00065	.000715	.00078	.000845	.00091	.000975	.00104	.001105	.00117	.001235	.0013	
14	.00014	.00021	.00028	.00035	.00042	.00049	.00056	.00063	.0007	.00077	.00084	.00091	.00098	.00105	.00112	.00119	.00126	.00133	.0014	
15	.00015	.000225	.0003	.000375	.00045	.000525	.0006	.000675	.00075	.000825	.0009	.000975	.00105	.001125	.0012	.001275	.00135	.001425	.0015	
16	.00016	.00024	.00032	.0004	.00048	.00056	.00064	.00072	.0008	.00088	.00096	.00104	.00112	.0012	.00128	.00136	.00144	.00152	.0016	
17	.00017	.000255	.00034	.000425	.00051	.000595	.00068	.000765	.00085	.000945	.001035	.001125	.001215	.001305	.0014	.001485	.001575	.001665	.00175	
18	.00018	.00027	.00036	.00045	.00054	.00063	.00072	.00081	.0009	.00099	.00108	.00117	.00126	.00135	.00144	.00153	.00162	.00171	.0018	
19	.00019	.000285	.00038	.000475	.00057	.000665	.00076	.000855	.00095	.001045	.00114	.001235	.00133	.001425	.00152	.001615	.00171	.001805	.0019	
20	.0002	.0003	.0004	.0005	.0006	.0007	.0008	.0009	.001	.0011	.0012	.0013	.0014	.0015	.0016	.0017	.0018	.0019	.002	
30	.0003	.00045	.0006	.00075	.0009	.00105	.0012	.00135	.0015	.00165	.0018	.00195	.0021	.00225	.0024	.00255	.0027	.00285	.003	
40	.0004	.0006	.0008	.001	.0012	.0014	.0016	.0018	.002	.0022	.0024	.0026	.0028	.003	.0032	.0034	.0036	.0038	.004	
50	.0005	.00075	.001	.00125	.0015	.00175	.002	.00225	.0025	.00275	.003	.00325	.0035	.00375	.004	.00425	.0045	.00475	.005	
60	.0006	.0009	.0012	.0015	.0018	.0021	.0024	.0027	.003	.0033	.0036	.0039	.0042	.0045	.0048	.0051	.0054	.0057	.006	
70	.0007	.00105	.0014	.00175	.0021	.00245	.0028	.00315	.0035	.00385	.0042	.00455	.0049	.00525	.0056	.00595	.0063	.00665	.007	
80	.0008	.0012	.0016	.002	.0024	.0028	.0032	.0036	.004	.0044	.0048	.0052	.0056	.006	.0064	.0068	.0072	.0076	.008	
90	.0009	.00135	.0018	.00225	.0027	.00315	.0036	.00405	.0045	.00495	.0054	.00585	.0063	.00675	.0072	.00765	.0081	.00855	.009	
100	.001	.0015	.002	.0025	.003	.0035	.004	.0045	.005	.0055	.006	.0065	.007	.0075	.008	.0085	.009	.0095	.01	
200	.002	.003	.004	.005	.006	.007	.008	.009	.01	.011	.012	.013	.014	.015	.016	.017	.018	.019	.02	
300	.003	.0045	.006	.0075	.009	.0105	.012	.0135	.015	.0165	.018	.0195	.021	.0225	.024	.0255	.027	.0285	.03	
400	.004	.006	.008	.01	.012	.014	.016	.018	.02	.022	.024	.026	.028	.03	.032	.034	.036	.038	.04	
500	.005	.0075	.01	.0125	.015	.0175	.02	.0225	.025	.0275	.03	.0325	.035	.0375	.04	.0425	.045	.0475	.05	
600	.006	.009	.012	.015	.018	.021	.024	.027	.03	.033	.036	.039	.042	.045	.048	.051	.054	.057	.06	
700	.007	.0105	.014	.0175	.021	.0245	.028	.0315	.035	.0385	.042	.0455	.049	.0525	.056	.0595	.063	.0665	.07	
800	.008	.012	.016	.02	.024	.028	.032	.036	.04	.044	.048	.052	.056	.06	.064	.068	.072	.076	.08	
900	.009	.0135	.018	.0225	.027	.0315	.036	.0405	.045	.0495	.054	.0585	.063	.0675	.072	.0765	.081	.0855	.09	
1000	.01	.015	.02	.025	.03	.035	.04	.045	.05	.055	.06	.065	.07	.075	.08	.085	.09	.095	.10	

Courtesy of H. Boker & Co., New York.



THE CONSTRUCTOR



Electric Turn-table for Private Garages

By H. JOHNSTONE

THERE are many convenient as well as protective features which anyone owning an automobile may install at slight expense, particularly if they do the work themselves in or about their garage. It often happens, as in the writer's case, that the car has to be driven in along a road winding beside the house and running directly into the garage, which means that in coming out, the car has to be backed out, and experience has shown that not everyone is so expert in driving a car backwards, that he can miss stones and other impediments encountered along such drives. The writer strongly believes in the utility of a turn-table for turning the car after it has been run in to the garage, so that it can be steered out on the main road in a forward direction.

Details and plans showing several suggestions for building a turn-table for a private garage are given in Fig. 1. Fig.

Including Several Types of Garage Burglar Alarms

1-A shows a square or other shaped garage of sufficient size to accommodate the turn-table, which latter will usually measure about 12 to 15 feet in diameter, all depending of course upon the total length of the car.

The turn-table can be made of such a size as to just include the wheel base length of the car. For the small garage which just accommodates the car and where it is not desirable to enlarge the garage, in order to contain the turn-table, this convenient device can very easily be placed outside and in front of, or to one side of the garage as convenience and space may dictate.

The main features that interest the

prospective builder of such turn-tables are what material they should be built of, how they should be arranged so as to rotate easily, and how to rotate them. Figs. 1-C to 1-H show some of the details which may prove valuable in the reader's particular case.

To begin with, the thicker the floor of the turn-table is made, the better; it is best to try and obtain maple, yellow pine or other tough flooring about 1 1/4 to 1 1/2 inch thick at least. The flooring should be placed across the beams, the same as in the usual building construction. For the average size car weighing 1,500 to 2,000 pounds the timber understructure may be composed of what is known as 2 by 6-inch wood beams, placed about 10 inches apart. This can be strengthened a great deal by two or three series of cross-braces formed of 1x3-inch stock, as shown at Fig. 1-C. Around the edge of the turn-table, under these beams, on a

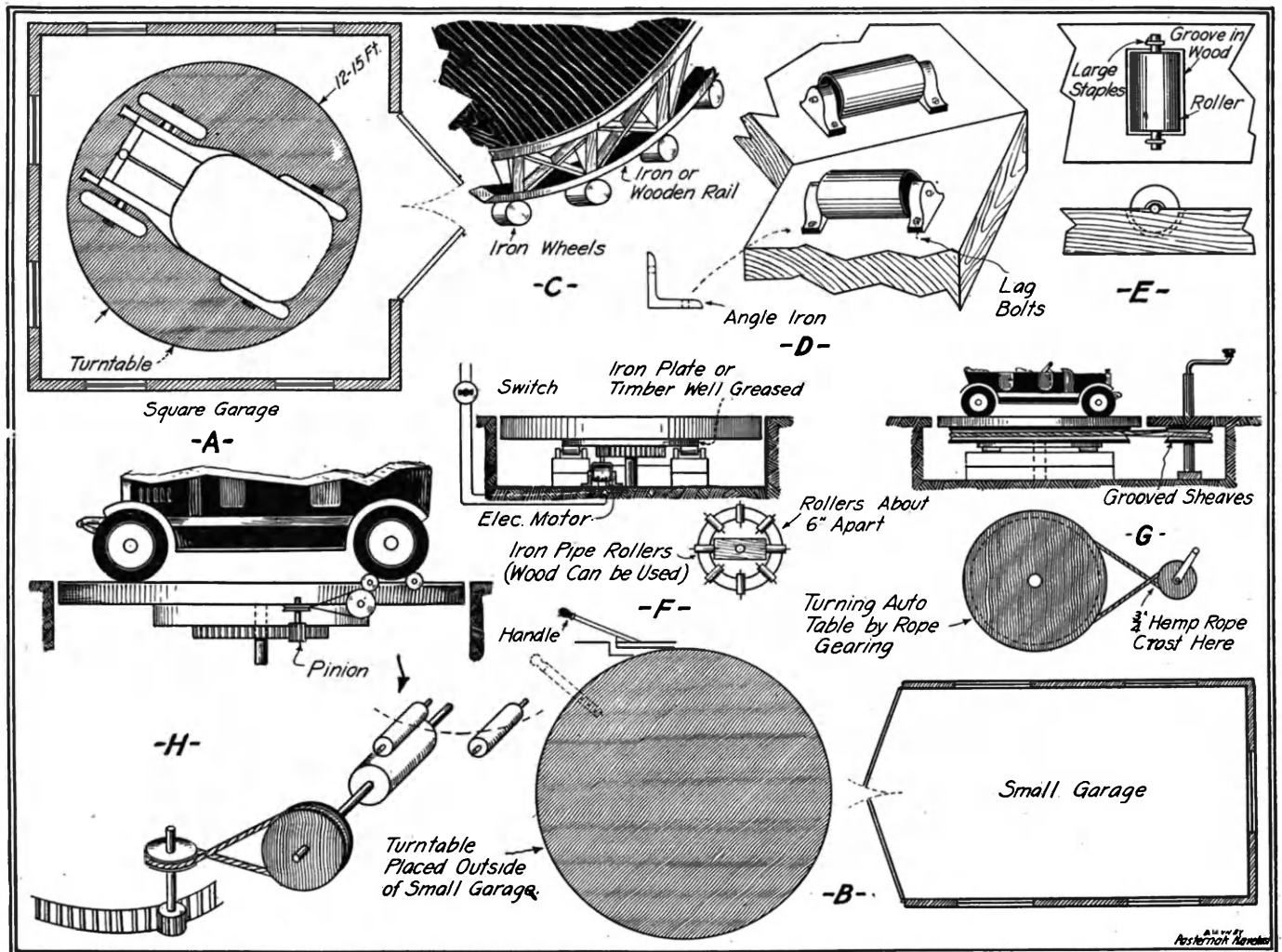

Fig. 1. Details Are Shown Above for Constructing a Home-Made Mechanical or Electrically Operated Turn-Table for the Private Garage. At Fig. H Is Shown An Ingenious Scheme Whereby the Power of the Car Itself Is Made to Revolve the Turn-Table, By Simply Placing the Rear Car Wheels On Two Rollers Which Can Be Connected By Chain Belt or Rope Gearing to the Pinion Meshing With a Stationary Gear.

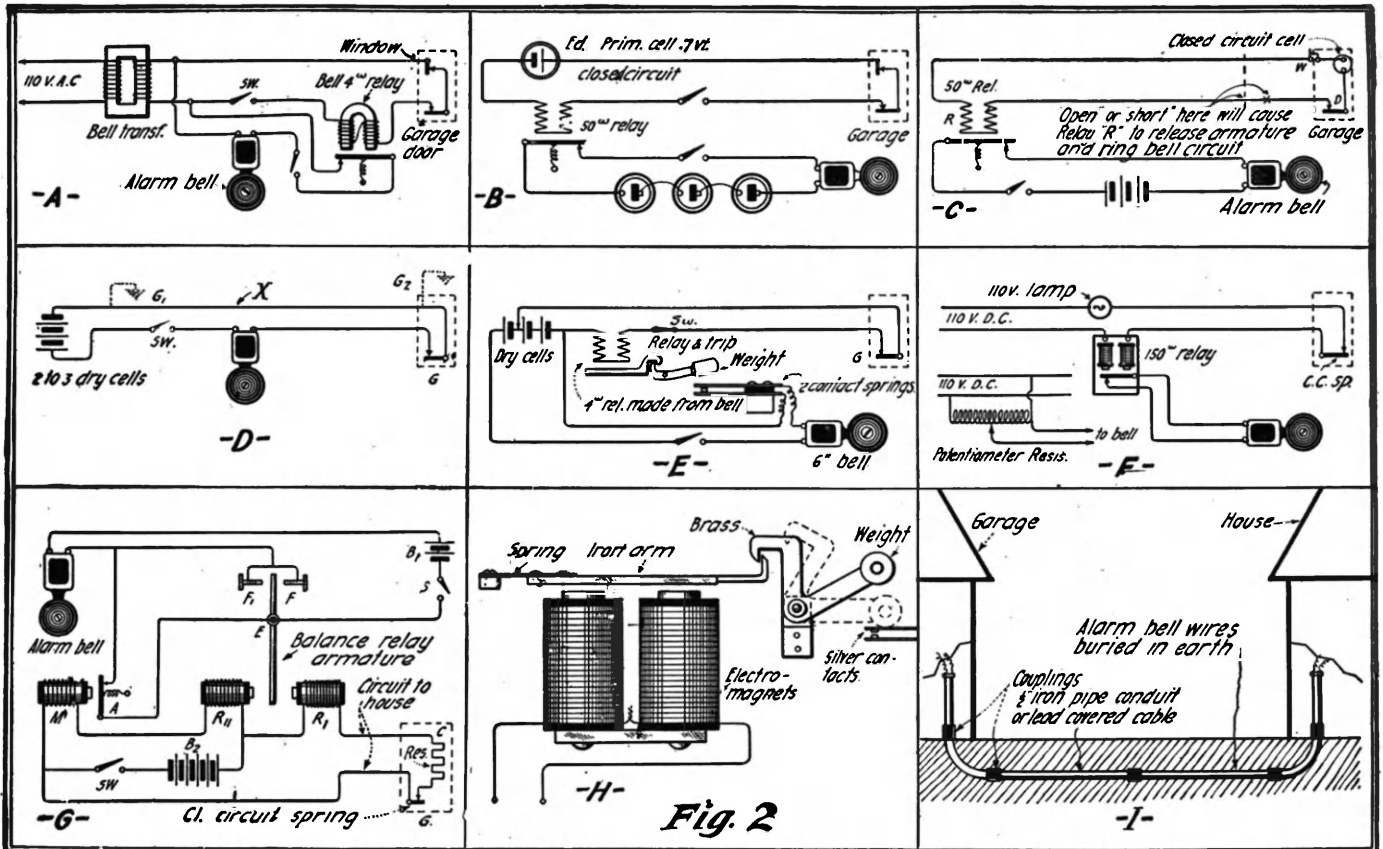

Fig. 2

Above Are Shown Several Varieties of Electric Burglar Alarms for the Protection of Private Automobile Garages. At the Present Time When So Many Auto Robberies Are Being Reported Daily, It Behooves the Owner of a Car to Provide Himself With Every Protective Means Possible. Some Owners Have Adapted Burglar Alarm Systems Directly to the Autos; in Some Cases a Bell Will Ring If Anyone Attempts to Drive the Car Off, While It Stands By the Curb. If a Closed Circuit System Is Not Employed for the Garage Alarm System Then It Is Best to Place the Wire Underground As Shown at Fig. 1.

diameter equal to that of the turn-table or somewhat less, a substantial circular iron or wooden rail should be placed, which is designed to rest on either roller or wheel bearings as shown in the detail drawings, C, D and E. If roller bearings are placed under the turn-table, these can be constructed from hard wood with an iron rod passing thru a hole drilled thru their centers, the rollers being not less than 2" in diameter and the iron rods being of 1/2" diameter stock.

Suitable bearings can be cast of babbit metal with flanges and holes as shown at D, so that they can be securely fastened to a timber sub-base by means of lag bolts. The bearings for the roller shafts can also be formed of pieces of angle iron as shown at Fig. 1-D. With a hole drilled thru both webs, one to accommodate the shaft and two in the base web to anchor it in position by means of lag-bolts. Ordinarily, the rollers which might be constructed also of iron pipe with wooden plugs driven into each end and a shaft passing thru the center, should be spaced about 7 to 8 inches apart. The length of the rollers need be only 4 to 5 inches.

At Fig. 1-F a circuit and arrangement is shown for a small electric motor used to rotate the turn-table. With the ordinary car, the turn-table can be rotated easily by simply pushing on the car, or else by placing a handle at an angle as shown in Fig. 1-B. A 1/4-horsepower electric motor will rotate the turn-table in about one-half minute or less with the weight of the car on the table, if roller or wheel bearings are used. Altho not rotating so easily or with the same minimum of power, the turn-table can be further simplified by substituting for the wheel or roller bearings, simple flat wood plank surfaces smoothed up as well as possible, which surfaces must be kept well lubricated with soap, or a heavy grease such as Albany grease.

If an electric motor is used under the turn-table, the small pinion on the shaft

of the motor is caused to mesh with a large gear, having about 100 or more times as many teeth as the pinion, and which gear is rigidly fastened to the central shaft of the turn-table. The center shaft may be composed of a piece of steel shafting or else a piece of pipe two to three inches in diameter, and further description of this simple part of the device is unnecessary.

Another suggestion for rotating the turn-table by means of a hand gear is shown at Fig. 1-G. Here a rope, belt or chain has to be arranged to drive the turn-table by means of two grooved pulleys or sheaves. The belt is crost so as to get as much of an arc of contact as possible on the small pulley which should be not less than one foot in diameter. Fig. 1-H shows a suggestion made by Mr. H. Gernsback, whereby the automobile can be made to rotate the turn-table itself. This is accomplished in a very simple manner by arranging two rollers just at a point where they will come in contact with the rear wheel. Provision would have to be made of course to bring one of these rollers in contact with a friction driven wheel as shown in the sketch, this driving wheel being belted or geared in a simple manner to a vertical gear shaft which carries a pinion on its lower end. This pinion in turn, meshes with a large stationary gear, and in this manner rotates the turn table.

GARAGE BURGLAR ALARMS.

We will here consider briefly a review of the principal types of burglar alarm circuits suitable for garages. Fig. 2-A to 2-I illustrates some of the details of burglar alarm circuits each of which has merits of its own, some being simple and others tho a little more complex, having decided advantages which will appeal to many.

Fig. 2-A shows how a bell-ringing transformer reduces the potential of a

service line to about 6 volts. Employing a relay having a resistance of from 4 to 8 ohms and which may be constructed from a discarded bell or buzzer, a closed circuit system may be used as shown at A. Closed circuit contact-springs for doors and windows in the garage are used, and normally current passes thru the relay holding its armature against the magnets. Should either wire be cut, or the door or window be opened, thus open-circuiting the contact springs, the relay armature will be released and fall against the stationary contact shown, closing the alarm bell circuit.

The diagram at Fig. 2-B shows a simple and effective closed circuit system, employing one or two cells of Edison primary battery. These cells are thoroly adapted to closed circuit work, and have the advantage over gravity and other similar cells, of not deteriorating in the least when standing on open circuit. A relay having about 50 ohms resistance is suitable for a single Edison cell, and this may be constructed from a discarded bell with the magnets rewound with a fine wire. The relay closes the local dry battery circuit thru the bell, if the wires are cut or the alarm springs opened by an intruding burglar "jimmying" the window or door.

The diagram given at 2-C shows how three different things may be accomplished with the circuit shown at "B"; firstly, the bell will ring if the thief opens the window or door; secondly, if he cuts the wire or wires; or thirdly—if he short-circuits the wires. These results are accomplished by placing the closed circuit Edison primary battery of one or more cells in the garage, and the relay in the house.

The diagram at Fig. 2-D shows the simplest garage alarm one can install. This is an open circuit alarm using two or more dry cells with an ordinary bell and switch. It is not necessary to run two wires from the house to the garage,

(Continued on page 79)

Electric Weather Forecasting For Amateurs

By EVERETT LEO DEETER

FROM time to time articles appear in the technical magazines on Weather Forecasting. This is an interesting study if one possesses the necessary registering instruments. As most of these are quite ex-

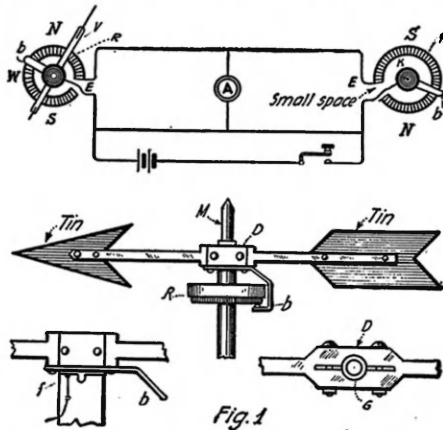

A Simple Wind Direction Indicator, Operating on the Wheatstone Bridge Principle. When the Rheostat Arm is Under the Same Relative Position as the Weather Vane Arm, the Galvanometer will Have no Current Passing Thru it, Giving Zero Deflection. By Calibrating the Rheostat for the Various Positions of the weather Vane, the Direction of the Wind Can Thus be Read off at Any Instant.

pensive for the average amateur, it is the purpose of this article to assist him in the making of his own apparatus.

The following description and figures will enable one, with the aid of the usual shop tools, to construct and erect in his own home or laboratory an outfit necessary for the measuring of rainfall, the direction and the speed or pressure of the wind. The instruments are connected electrically to the registering meters. To this group may be added an accurate barometer and a thermometer, making a complete forecasting outfit.

The wind direction indicator is of a unique type and makes use of the Wheat-

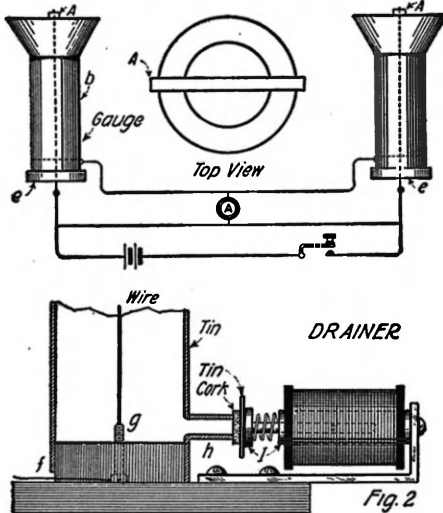

This Home-Made Rain Gage Works on the Same Principle as the Wind Direction Indicator Illustrated at Fig. 1, i.e., the Galvanometer "A" Shows Zero Deflection When the Same Amount of Water is Placed in the Laboratory Container as that Registered at the Moment in the Out-door Rain Gage; Thus the Amount of Rain in the Exterior Container is at Once Known.

stone bridge circuit in recording, as also do the rainfall instruments.

In constructing this indicator two small porcelain base rheostats are used, both of the same resistances, which should be rather large. One is secured to the vane as shown in Fig. 1, and the other is placed on a wooden base, somewhat larger, on which the points of the compass are graduated. This should be done by test as follows: After the completion of the vane, which should be well balanced, the two resistances R are wired in circuit as shown. Then if the wind is from the SW, for illustration, the contact arm on the vane will fall as shown. If the indicating rheostat is then adjusted until no current flows thru A, equal amounts of resistances will be in circuit at both rheostats, and the arms will be in the same corresponding place, as shown, between S and W. With the use of a compass, and by turning the vane by hand and holding it in the N, W, S and E directions while another graduates the indicating rheostat, it is an easy matter to finish the graduation as the divisions are all equal.

In Fig. 1, G is a brass collar, the bearing of the vane, which rotates about the steel pin M. The brush arm b is of spring brass and rests on a brass washer f, to which is soldered the connecting wire. Do not oil this junction, thus spoiling the electrical connection.

The rain gage tanks are constructed of heavy brass or galvanized iron, in the form shown. The top conical portion measures eight inches across the top. The lower portion measures twenty inches high, and has a diameter of 3.52 inches. On this scale the actual rainfall is only one-fifth of that in the tank. If it is wished to measure the snowfall it will be necessary to add a heating unit to the gage. This may be accomplished by wrapping the lower portion of the gage with asbestos, then with a thermo-resistance wire, and another layer of asbestos. The whole is then covered with a fire-proof enamel. When connected in circuit with the correct voltage the resistance wire becomes heated, thus melting the snow, which may then be measured.

The rain gage and circuit are shown in Fig. 2. A heavy brass wire, insulated from the gage, extends from the hard rubber support to the base, which is also of hard rubber and sealed to the lower end of the tank.

Here it is soldered to a bolt at g, from which connection is made, passing out at f thru a bushing. The other connection consists of a wire soldered to the tank b.

Suppose that two inches of rain fall into the gage. Then closing the bridge circuit we find a current flows thru A, which passes thru the water in the gage. If water is now added to the similar recording gage some of the current divides and passes thru the resistance of the water. When the amount of water in each is equal the ammeter A will read zero, as the resistances of the two are the same. The height of water in the latter will then equal that in the receiving gage exposed to the weather. In measuring it must not be forgotten that the gage magnifies five times. It must also be remembered that the tanks must be identical in size, and the wire in each must be placed in the same place, directly in the center, and the circuit resistantly balanced. It is necessary to have a supply of rain-

water on hand to use in the indicating gage if accurate results are to be had, as the resistance of rainwater differs somewhat from that of well water. The voltage required in this circuit will be rather large, and is best found by experiment,

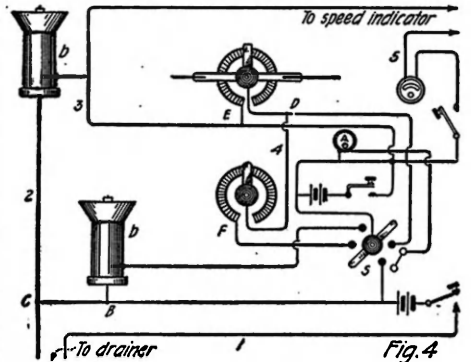

The Diagram Above Shows the Circuits Employed with all of the Weather Forecasting Apparatus Here Described.

as the conductivity of the water differs in the various parts of the country.

As it would be necessary to drain the gage quite often, an automatic drainer is made use of, and is illustrated in Fig. 2. When current is applied to the electro-magnet the plunger is drawn back and the gage is drained. A tin shield on the plunger protects the electro-magnet. The pieces I are of soft iron. A pet-cock may be attached to the indicating gage for drainage.

The wind speed indicator, as shown in the illustration, Fig. 3, is quite simple. A permanent magnet, rotated by the wind cups C, passes over two electro-magnets and generates a voltage in them, which is registered on a volt-meter or frequency meter. The electro-magnets are not connected by a back cross yoke, as in a low wind the permanent magnet would have a tendency to stop when it past over them.

(Continued on page 84)

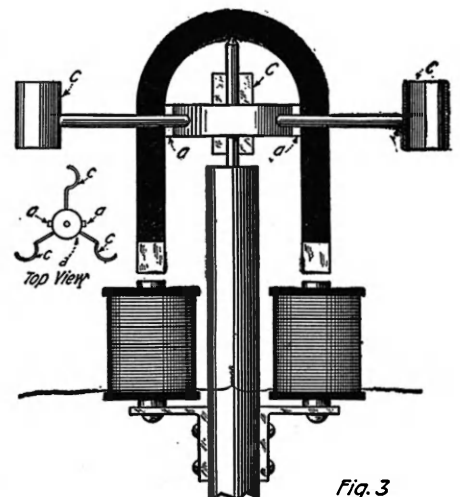

A Very Ingenious Wind Speed Indicator is Shown in the Illustration Above. The Cups Which Catch the Wind and Spin the Arms Around at a Speed Proportional to the Velocity of the Wind, Carry with Them a Horse-Shoe Magnet which Produces an Emf. in the Circuit Connected to the Stationary Electro-Magnets, which Emf. Can be Registered or Indicated in Any of the Usual Ways.

Paraffin--Its Properties and Use

THE word paraffin indicates "little affinity." It is applied to a group of compounds of carbon and hydrogen of varying composition, but all following rigorously the following formula. The molecule, of any one paraffin,

to constitute the arrangement of a hydraulic trough. By this simple device, marsh gas can be collected in considerable quantities, but naturally impure.

When we go up the line, we find after a while, that paraffins containing more atoms of carbon in the molecule are liquids and these are present in oils (common kerosene is an example), which may contain a large percentage of paraffin.

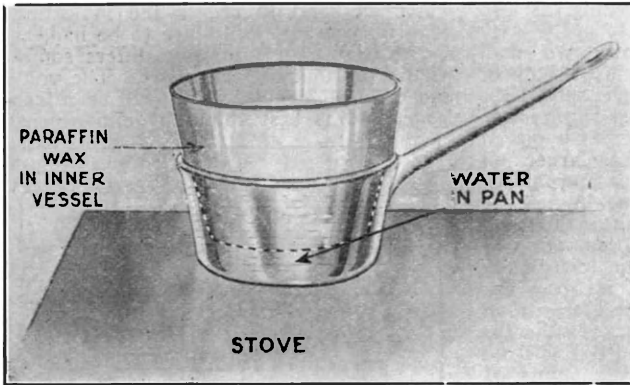

How to Melt Paraffin Wax Safely. The Pan Containing the Wax Is Placed in a Larger Vessel Filled with Water.

Continuing on our way, we find solid paraffins containing in each molecule, a comparatively large number of atoms of carbon, and these may be soft like vaseline, or with more

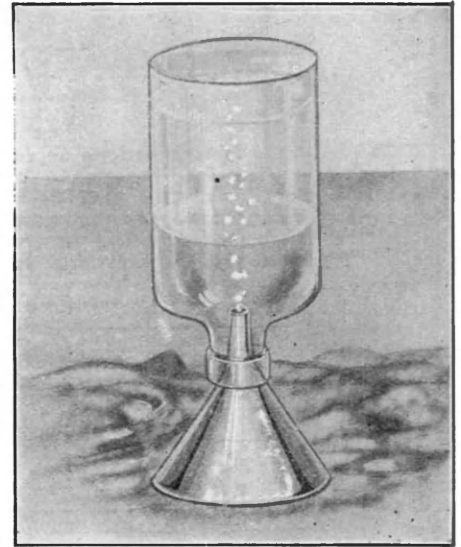

Collecting Marsh Gas (or Paraffin Gas) from Decaying Matter in a Swamp.

contains twice as many hydrogen atoms as it does carbon atoms, plus two. Thus, a paraffin containing only one atom of carbon in its molecule, contains four of hydrogen; one containing two atoms of carbon, contains six atoms of hydrogen, and so on.

In going far up the series, a paraffin containing twelve atoms of carbon for instance in its molecule, would contain twenty-six atoms of hydrogen. The more carbon a paraffin contains, the less volatile it is. Starting off with the molecule containing a single carbon atom, we have in this compound a gas so light that it may be used for inflating balloons, and which burns with a slightly yellow flame of hardly any illuminative power.

Marsh gas (as this compound is called), is interesting in its way; it is a prominent constituent of coal gas, and is produced in the destructive distillation of many kinds of organic matter, and in many cases is evolved from decaying matter. It can often be collected in swamps. A funnel is inverted in swampy water covering decaying vegetable matter, and a bottle full of water is inverted over the funnel stem so as

carbon in the molecule, may be hard as a piece of wax, and in this case are called solid paraffin, paraffin, or paraffin wax. Carbon, itself, is black, except in the diamond, but in a paraffin compound, colorless gas, colorless liquids, or pure white solids result from the combination of the black carbon with the gaseous invisible hydrogen.

Paraffin wax, snow white in color, almost odorless, tasteless, hard at ordinary temper-

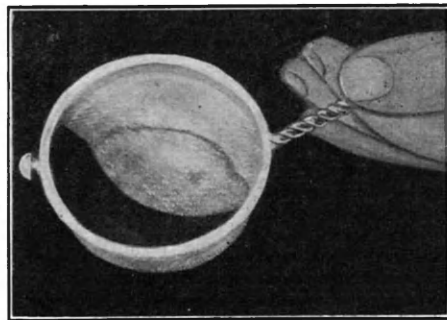

Carrying Water in a Sieve Which Has Been Dipped in Hot Paraffin Wax.

atures, absolutely water-repellant, is used in great quantities in electrical work. It is an almost perfect insulator, and if melted around conductors, operates to exclude all moisture. Even if the conductors, by accident, have become somewhat moist, the hot paraffin wax poured over them (as in tubular casings, junction boxes, and the like) will at least do some work in the way of expelling all the moisture, and will exclude it in the future.

The wax melts with great readiness, to a clear liquid which will penetrate everywhere. The safest way to melt it is in a double sauce-pan or water-bath. This is especially recommended to the housewife who may be using it to pour over her preserves. If heated directly on the stove it may get so hot as to be dangerous, owing to the fact that it may ignite and spread to the person's clothes.

In the city streets, where electricians are working in a manhole, the paraffin pot, in
(Continued on page 89)

A Compensated Selenium Cell

By W. L. GRIPENBERG

(Note.—Mr. Gripenberg, of Finland, is probably the greatest living authority on selenium cells. He has invented many new types, and his cells are considered the most sensitive ever built.—EDITOR.)

IN several applications of the selenium cell it is highly desirable that the dark-current should be as small as possible; in order to achieve this the so-called differential connection is used; an equal current is sent in opposite directions through the apparatus actuated by the photo-electric current.

Clever Scheme Perfected by the Author for Making An Accurately Balanced Duplex Selenium Light Sensitive Cell, for Use in a Differential Circuit.

Selenium is very sensitive to changes in temperature and moreover is liable to spontaneous, gradual changes in resistance, going on slowly for months and years; it therefore is necessary to use as resistance in the compensating circuit a selenium cell in every respect similar to the "feeler"-cell.

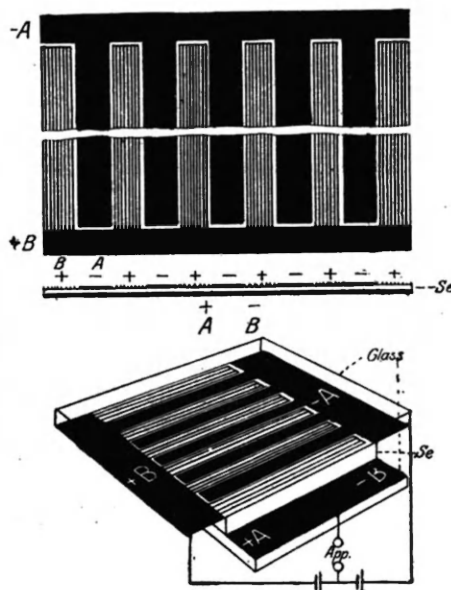

But similar cells are difficult to make and usually behave differently afterwards.

In order to attain identical behavior under all circumstances, the writer has had recourse to the expedient of using the same plate of selenium for both cells; there was however still the fact to keep in view that comparatively great inequalities are to be found even in the same piece. The violent contraction during crystallization produces cavities, etc., in the interior.

The difficulty was finally overcome by using alternate strips of the plate for the two circuits.

The narrowness of the strips was limited by the fact that the light action travels a certain distance into the darkened parts of the selenium—also laterally—quite an appreciable way, altho by no means so great a distance as in single crystals, as discovered recently by Dr. F. C. Brown. (In fact, a plate consisting of a single individual crystal can be made, but not yet commercially; it could not be used for the present purpose.)

The figures show the construction as
(Continued on page 92)



HOW-TO-MAKE-IT



This department will award the following monthly prizes: First prize, \$5.00; second prize, \$3.00; third prize, \$2.00. The purpose of this department is to stimulate experimenters toward accomplishing new things with old apparatus or old material, and for the most useful, practical and original idea submitted to the Editors of this department a monthly series of prizes will be awarded. For the best idea submitted a prize of \$5.00 is awarded; for the second best idea a \$3.00 prize, and for the third best a prize of \$2.00. The article need not be very elaborate, and rough sketches are sufficient. We will make the mechanical drawings. Use only one side of sheet. Make sketches on separate sheets.

FIRST PRIZE, \$5.00

CLOCK WITH LUMINOUS DIAL

A clock arranged so that the dial can be illuminated from the inside, at night, when it is desired, is very novel and use-

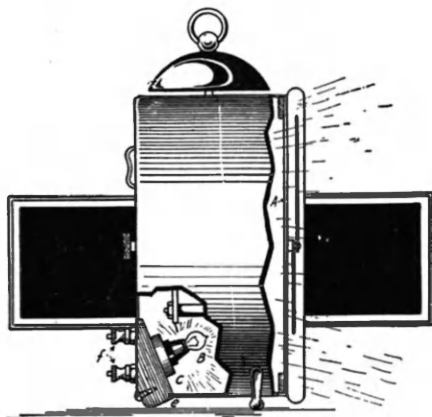

The Lay-Out of the Luminous Dial Clock Is Clearly Shown With the Incandescent Lamp in Its Base.

ful. Any clock can be arranged thus by one or two changes to wit:

The ordinary metal dial (A) will have to be removed and a semi-transparent one put just in its place. A good way to make this, is to first cut out a disc of thin celluloid, taking pains to get the size of same correct, and then paste smoothly over this, a piece of thin bond paper,—a tinted paper produces a good effect. The figures of the hours can then be neatly made on the paper, and the dial with appear similar to an ordinary one until lit up from behind.

It will of course be necessary to punch holes in this dial for the various hands. For the light, a small flashlight bulb (B) is sufficient, placing it near the back.

The socket (C) can be mounted on some insulating material such as fiber, etc, (E) which in turn is secured to the back of the clock as shown. The lamp terminals are brought out to two binding posts (F) on the outside of the clock one of which must be insulated therefrom.

Contributed by JAMES P. LEWIS.

ELECTRIC TOY GUN

How many of us experimenters have often desired to make a gun which will

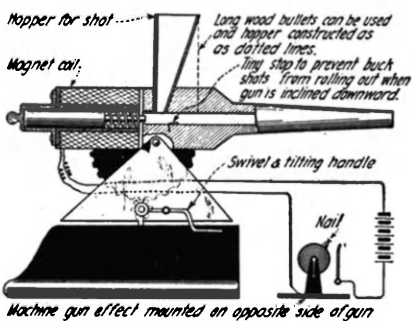

How to Build a Toy Electric-Magnetic Gun.

SECOND PRIZE, \$3.00

A SAFE REMINDER

A bookkeeper friend of mine was troubled with chronic forgetfulness, so much so that he often forgot to lock the safe when he left the office. I then made the following attachment, which has given great satisfaction.

At first, I fastened a set of contacts to the safe by means of a small bolt, in such a manner that when the safe is locked the contacts will be separated by the action of the handle. I then ran two wires from this contact to the top side of the safe, fastening them at this point to another "contact-breaker" of the special construction shown in the diagram. On opening the safe in the morning, the bell will continue to ring until he hangs up his hat; and on leaving at night the bell will ring until he locks the safe. The wiring is entirely insulated from the safe but if desired, one side of the battery can be grounded thus employing the iron structure in place of one of the wires.

Contributed by C. C. CAMPOS.

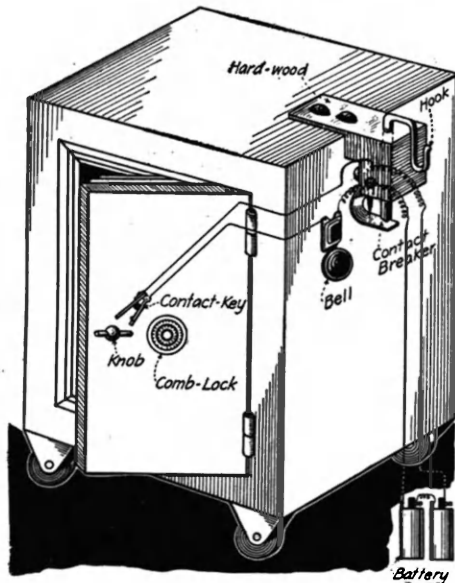

Helping the Memory So That You Will Not Forget to Lock Your Safe. Remove Your Hat With Door Open—Bell Rings.

not necessitate a series of solenoids and still work by means of the old standby (juice). Perhaps some of us have been lucky enough to build one on the principle of the gun featured in this magazine some time ago, which theoretically hurled the projectiles 90 miles.

But, here we have an electromagnetic gun comprised of a single solenoid, a receiver, for the bullets which can be wood, metal, or anything else equally as effective, and a machine gun arrangement so that rapid firing can take place by means of the commutator device.

Essentially, a metal bore, a pipe or other suitable tube thru which these projectiles are to pass, is mounted on a wooden base so that to be able to swing laterally and

(Continued on page 92.)

THIRD PRIZE, \$2.00

PAPER DIAFRAM FOR 'PHONE

A very good way to modify the strength of the tone in the receivers when at code practice is to make a paper diafram. The face of an old business envelope is about the right material and thickness. Into this diafram insert a small steel sewing needle

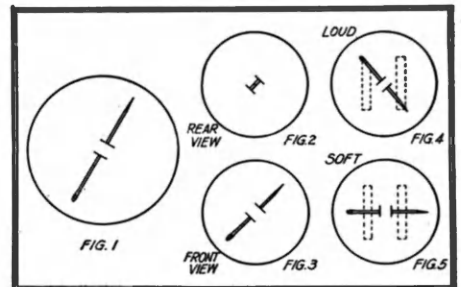

Modifying the Loudness of the Code Signals With a Paper Diafram and a Steel Needle.

as in figure 1. This needle should run only part way through the paper as in figure 2 and 3. This diafram is substituted for the regular one. The strength may be varied by changing the relation of the needle to the pole-pieces as in figures 4 and 5. Static noises may be imitated by working the needle holes larger.

Contributed by DURWARD GUTH.

BALANCE WHEEL MOVES WATCH.

Almost everyone knows that one of the fundamental laws of physics states that to every action—there is an equal and opposite reaction. But very few persons would think that when this law is applied to a watch, the balance wheel tends to turn the watch in the opposite direction five times a second.

This can be easily shown by suspending a watch or small clock by four cords so that it can rotate freely with the face parallel to the ground. A small mirror is attached to one side with a piece of wax in a vertical position. When the watch is apparently motionless a beam of light is directed on the mirror and the reflected spot will be seen to vibrate in synchronism.

Contributed by CLYDE KEITH.

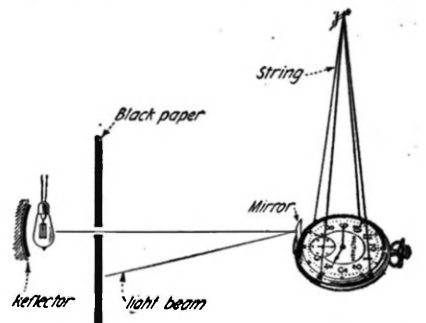

That the Balance Wheel of a Watch Will Move the Whole Watch Is Surprising.



EDITED BY S. GERNSBACK

Interesting Chemical Experiments

By O. IVAN LEE, B. Sc.

How to Make Fire Burn On Ice

Carbid or more properly, calcium carbid, is a wonderful substance made in the electric furnace by heating lime and coke. It is a hard grey stone-like material and no doubt familiar to you as the gas-generating medium employed in some kinds of bicycle lamps. When brought in contact with water it



If a Few Lumps of Carbide are Placed on a Block of Ice, the Heat Generated by the Chemical Reaction Will Begin to Bore Little Holes in the Ice. If the Acetylene Gas Evolved can be Ignited the Ice Appears to be Burning.

instantly liberates the gas, acetylene, which gives a brilliant light when properly burned.

This property can be strikingly demonstrated in the following manner:

Place a few lumps of carbid on a block of ice. Above the freezing point of water (32 degrees F) ice is always covered with a film of water sufficient to start some action with the carbid. The heat generated by the chemical reaction melts more ice, making more heat and generating more gas, so that in a moment, the lumps will have begun to bore little holes in the ice. If a match is applied, the escaping acetylene gas ignites and burns with bright but smoky flames so that to the observer the ice appears to be burning. Since acetylene gas contains, much carbon, when it is burned in the air without special burners, it gets insufficient oxygen to burn up all this carbon. As a consequence of this richness in carbon, or insufficient oxygen, a veritable "black snowstorm" results in a few minutes. On this account it is advised that the experiment be performed outdoors, but not on Monday! (Wash-day.)

A Beautiful Experiment

Most substances which dissolve in liquids to give colored solutions, confer the same color on the fluid regardless of whether you look at it or thru it. For instance, if a little bluing is put into a glass of water, the water looks blue no matter how you look at it, the only difference being that in some positions the color may appear darker than in others. In the language of science, the light transmitted is the same as that reflected. There are a limited number of substances, however, which in solution

have the wonderful power of reflecting a different color of light from that which they transmit. One of these substances is the dye eosin, widely used for making red ink.

Fill a tall glass pitcher or similar vessel with water and if possible put it in bright sunlight. When the water is quiet, drop a little red ink on the surface with a medicine dropper. As the dye dissolves and descends in smoke-like swirls, you will be astonished at the delicate apple-green color reflected entwined with the rosy pink to be expected. The green color may be intensified by viewing the solution against a black background. On the other hand, if you hold the solution against the sunlight or look thru it at a sheet of white paper, it will appear almost exclusively pink. If the solution is diluted with increasing volumes of water, you will find that the green light is much more persistent than the pink and will manifest itself long after the pink has vanished.

If no red ink is available, perhaps you have some quinine tablets in the medicine closet. Sprinkle a bit of this on the water or dissolve the pill if it is in pill form (if in a gelatine capsule, remove from capsule before using), and then add a few drops of sulfuric acid. If not to be obtained elsewhere conveniently, take a little from a storage battery, using a glass tube. As soon as the acid enters the solution, you will observe beautiful sky-blue streamers of light, yet if the solution is held against the light, it will be found entirely colorless!

Supposing that you have been disappointed in your search for red ink or quinine and sulfuric acid, perhaps you know where there is a horse-chestnut tree. If so, take a sharp pen-knife along, and when you have found the tree, cut away a small square of the rough black outer bark, and remove a few splinters of the soft red inner bark. Drop these on the water as described in the experiment with red ink and quinine. As with the latter, a powerful bright blue light floats down from the surface of the water. The effect is particularly fine when viewed from above, for then the blue light appears more concentrated, and it will be noticed also that the inside of the glass vessel, especially that nearest the source of light, appears to be lined with a kind of halo of blue light. As in the previous experiment, tho, the water appears nearly colorless against white paper. On standing awhile, a red coloring matter in the bark having no connection with the substance causing the blue light dissolves out and somewhat obscures the blue color.

In general, these experiments can not be so successfully carried out by artificial light, unless an especially powerful light is used such as an acetylene bicycle lamp. Since the particular kinds of light which are the cause of these beautiful reflected colors, can not pass through glass easily, better effects are obtained by concentrating the beam of light from the lamp directly on top of the water.

Some Experiments With Iodine

Pure iodine is a black, shining crystalline substance, looking much like graphite. Since

it is too concentrated and inconvenient to use in this form, druggists make a solution of it in alcohol and water, together with some potassium iodid (which also contains iodine). The potassium iodid is necessary mainly to make a strong solution, since neither water nor alcohol can dissolve much iodine unaided. This solution of iodine is

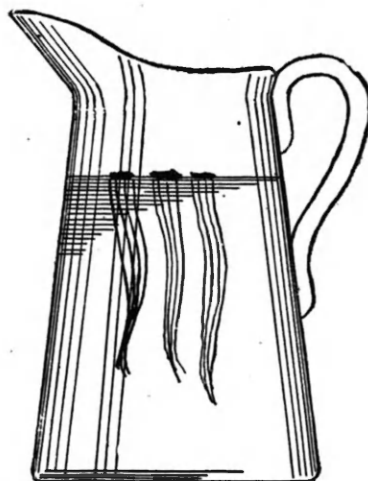

If Some Red Ink is Dropt into Clear Water in the Glass Pitcher You Will be Surprised to See the Various Colored Swirls which Sink Downward Thru the Water. Other Chemicals Give New Colors.

called tincture of iodine, and should be in every household for use on cuts and sprains.

How to Remove Iodine Stains

In applying tincture of iodine to a cut finger or a sprained ankle, some is very apt to get on fingers where it is not wanted or stains a handkerchief or towel. The brown stains resulting are quite soap- and water-proof and for lack of any other means, are usually allowed to wear off. If you have dabbled in photography at all, you must be well acquainted with sodium hyposulfite or just plain "hypo," as the photographers call it. Dissolve a couple of teaspoonfuls of "hypo" in a quarter glass of water, and pour a little into a glass of water which has been colored brown by adding a little tincture of iodine. Instantly the solution will be as white as any spring-water. Now put a drop of the tincture on your finger, let it dry, and then apply some of the hypo solution to the brown spot. It will disappear like magic. Old spots may require several applications and more rubbing.

Iodine has the power of forming a blue color with starch, the merest trace being sufficient. Drop a little tincture of iodine much diluted with water, in some corn-starch which has been rubbed in a spoon and heated a moment. A deep blue color will be formed—black if the iodine is too strong. The same experiment can be illustrated by adding a little of the tincture to a glass of water in which some library paste has been dissolved. With a little adjustment, a fair imitation of a glass of elderberry wine will be obtained.



RADIO DEPARTMENT



New York Radio Convention

THE Radio Convention and Exhibition organized by the Executive Radio Council of the second district which includes southern New York, Long Island, Staten Island and northern New Jersey, was a "howling" success. The radio convention and exhibition was held on the gigantic roof garden of the Hotel Pennsylvania during the days of March 16th to the 19th inclusive.

Our sister publication RADIO NEWS had a booth at the show and Mr. Robert E. Lacault, Associate Editor of RADIO NEWS, and Mr. Joseph H. Kraus, Field Editor of SCIENCE AND INVENTION, entertained hundreds of persons daily. Both publications as well as the various radio and electrical books published by these magazines were on sale.

The show was a great success both commercially and scientifically speaking. The army and navy officially recognized the show by sending excellent displays of apparatus, which were manned with expert operators from the respective arms of the service, and messages were received and transmitted every day. The various exhibitions of radio manufacturers, included both damp and undamp wave apparatus, while the majority of them featured two and three stage audion amplifiers used in connection with loud speakers fitted with big horns, particularly the Magnavox apparatus, whereby the dots and dashes as well as wireless telephone music poured forth in great volume.

The U. S. Navy installation was one of the best of the exhibits, and when the music was received from a U. S. Signal

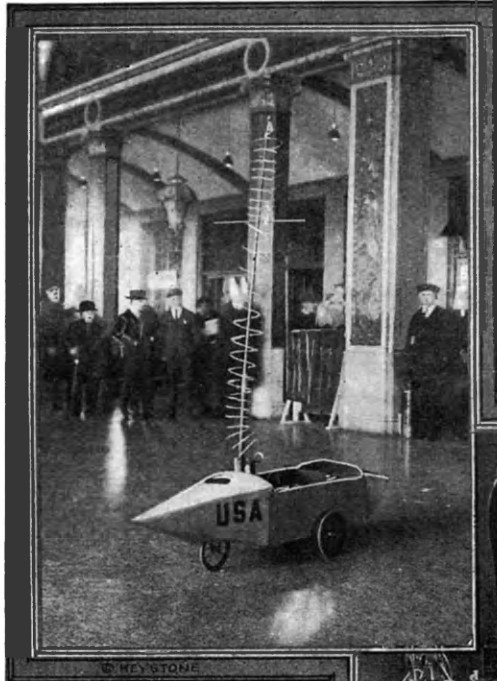
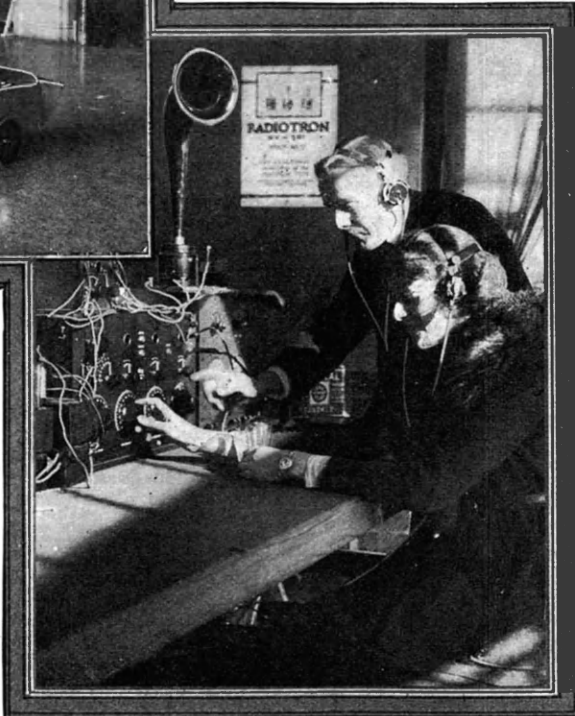

Photo At Left Shows Radio Controlled Car Which Was Operated By Wireless Waves at the Recent Radio Convention and Exhibition Held at the Hotel Pennsylvania, New York City. Photo Below Shows Miss Ethel Gladwin a Visitor at the Amateur Radio Show, Listening to An Incoming Message Being Received By Radiophone Instructor, Mr. R. R. Keller.



Corps station located near the Battery, New York City, it showed what fine tuning could be done and weeded out interfering radio-telegraph signals. It was remarkable to note how short an antenna was being used by the various exhibitors who had receiving sets working,—the army and navy using very short aerials. Of course the multiple stage audion amplifiers made this possible.

One of the biggest hits at the radio show was the daily exhibition of the wireless controlled torpedo which is shown in one of the accompanying photographs. The second photograph herewith shows Miss Ethel Gladwin listening to messages being received via radiophone, by R. R. Keller.

One of the features of the convention was a code speed test and the presentation of the silver loving cup suitably inscribed to the winner, Mr. B. G. Seutter, operator of the NEW YORK TIMES Trans-Atlantic radio receiving station, which was a feature of the banquet given on Saturday evening in the great ball room of the Hotel.

Mr. Seutter was saluted as Champion Radio Operator of the world in having established a new record by receiving 48-3/5 words per minute with only two typographical errors. The presentation of the loving cup to Mr. Seutter was made by Mr. J. O. Smith, Chairman of the Radio Committee and Toastmaster for the evening.

Mr. Seutter won his title in a contest conducted at the Exhibition and Convention Hall together with more than 60 other operator contestants; the former radio speed record of 47 words per minute with three errors was held by Tony Gerhart of San Francisco, an employee of the Radio Corporation of America.

Hymns by Radio

Church hymns by wireless telephone became a reality recently when the musical service at the Calvary Church of Pittsburgh, Pa., was sent out via the experimental radio station of the Westinghouse Company at East Pittsburgh. A private telephone line was installed between the church and East Pittsburgh, and the music collected in transmitters at the Calvary Church and transmitted over this line. It was then amplified and sent out over the radio telephone, making it possible for persons, having wireless receiving sets, within several hundred miles of Pittsburgh to hear the hymns.

May "Radio News"

- The Arc and Radiotelephone Transmission*
By John F. Bront
- The Construction of Intervalve and Telephone Transformers*
By Joseph Reeds
- The Efficient Design of Vacuum Tube Telegraph and Telephone Sets*
By Jesse Martzen
- A New Device to Obtain A C from a D C Supply*
By D. R. Clemons
- The Radio Compass*
By Lt. Com'dr. Frank Luckel,
U. S. Navy

Chinese Wireless

Announcements have appeared in the Peking, China, LEADER stating that the Government wireless station at the Temple of Heaven, Peking, is open for service, and that all telegraph offices in the city will accept radiotelegrams at the same rates as those charged for land-line messages for transmission to Kalgan, Wuchang, Woosung, Shanghai, and Foochow. Special rates apply to radiotelegrams sent to ship and aviation stations, and such messages are accepted only by the central office.

Ship Line Finds Use For Telemegafone

By ARTHUR H. LYNCH

A FEW months ago, when ex-Secretary of the Navy Daniels delivered a speech from the deck of the U. S. battleship *Pennsylvania* to an audience of several thousand, in Times Square, New York City, upon the return of the fleet from maneuvers at Guantanamo, Cuba, it was considered quite a wonderful communication feat, but little thought was given it as a forerunner of a decided change in the manipulation of our steamers.

In order to appreciate more fully just how shipping is being benefited by the application of part of the system used by ex-Secretary Daniels, a brief non-technical description of the entire undertaking will not be amiss.

Aboard the *Pennsylvania* there is a powerful wireless telephone equipment. A long cable from the radio set to the deck was connected to the transmitter, into which Mr. Daniels, delivered his speech. The radio waves from the *Pennsylvania* were thus controlled by the voice tones and converted from sound waves into electrical waves, which were sent into the ether, which is considered the medium thru which radio waves are propagated.

Up on the tower of the Times Building a number of radio engineers and Naval Communication Officers installed a complete wireless receiving outfit, for the purpose of picking up the speech from the battleship. By an application of amplifying apparatus the feeble impulses or ether waves which would have ordinarily been picked up at the receiving station, were brought up to sounds of great volume, being used to operate a device which is a combination of the telephone and megafone, called in electrical parlance a *telemegafone*.

In order that the crowd in Times Square could hear this greatly amplified sound, the telemegafone was installed in a window, on the second floor of the building and connected to the receiving apparatus in the tower.

MARINE USE MORE SIMPLE.

Under the direction of S. Lebowitz, Radio Supervisor of the Panama Line,

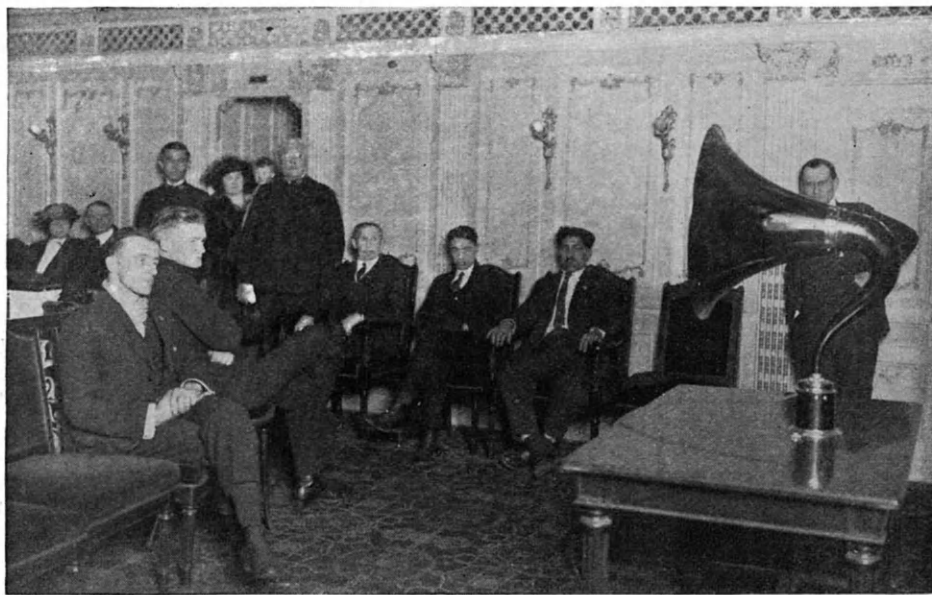

Photo Courtesy of Marine Journal.

The Telemegafone Is Here Shown in Successful Use on the Fall River Steamer "Plymouth" for Reproducing Band Music Picked up by the Ship's Radio Set. The Band Was Playing 50 Miles Away in New York City at the Time.

telemegafones are being used for a number of purposes. In this instance, however, the part played by radio is left out, and use is made of the direct amplification of the voice or music by an electrical method for local use.

The increase in the amplitude of the sound waves is so great that it permits vessels to carry on a conversation when more than three miles apart. This must not be confused with the short-range wireless telephone, which is being used so extensively. There are no electric waves. The distance is bridged by the amplified sound waves, produced by ordinary speech, and carried directly thru the air.

The captain on the bridge does not have to resort to the blinker, radio or any of the other means of inter-ship communication. All he has to do is talk into the transmitter, which is quite similar to the ordinary desk telephone.

REPLACING A BAND.

By applying the telemegafone to the phonograph, music of regular band volume is produced. Music is most entertaining aboard ship, but the ordinary phonograph variety is not well-suited for dancing in a large salon or on deck. A band is expensive and increased costs have eliminated them from most of our passenger vessels. In order to make travel on his line as fascinating as possible and live within reasonable cost limits, Mr. Lebowitz has taken advantage of this electrical substitute for the band and officials of the line and passengers have expressed great enthusiasm.

Another very valuable use for the telemegafone, which has been adopted by

the Panama Line, is the eliminating of the head phones, worn by the radio men while on "watch." On our passenger vessels, the radio men stay on watch from five to eight hours. By the end of the last hour the pressure of the telephones against the ears becomes uncomfortable. Now, the operator may be in any part of the room and listen to the traffic of other vessels without having a cable from the equipment running to his head.

OTHER APPLICATIONS POSSIBLE.

Running up New York Harbor, in mid-winter, at the helm of a tug, in the teeth of a stiff wind is not very uncomfortable, if the window of the pilot house is kept closed. In assisting a large steamer to berth there are generally a number of orders to be sent back and forth from the steamer to the tug and vice versa. The pilot house window does not long remain closed. By using the telemegafone, it becomes possible for the man in the pilot house to speak his orders into the transmitter and have them shouted thru the megafone, placed conveniently on the roof.

Orders for the movement of the lines, along the dock, could be given without the possibility of the officer in charge bursting a blood vessel, in an attempt to make himself heard above the roar of the wind. The direction of the megafone could be under the control of the officer, if a suitable rack and pinion device were attached. Officers, in other parts of the vessel could hear commands from the bridge without difficulty.

The illustration herewith shows passengers on the Fall River Line steamer *Plymouth* listening to a band playing in the Seventy-First Regiment Armory, New York City, altho they are fifty miles up Long Island Sound. Particular attention is directed to the fact that there are no instruments to be seen other than the telemegafone. The music was picked up by the steamer's radio instruments and then carried to the salon by a cable, which was connected to the telemegafone. The application of these instruments for the entertainment of passengers is becoming widespread upon steamers.

"Radio Vaudeville" Heard Miles Away

A "wireless vaudeville" performance was staged in the home of Robert F. Gowen at Ossining, N. Y., recently, and was transmitted by radio telephone to audiences miles away. One of the photographs shows Rosetta and Vivian Duncan, 'twin sisters in Fred Stone's "Tip Top," a New York theatrical success, starting their act before the transmitter. Among those present was Mr. I. R. Lounsberry, well known as an amateur radio experimenter, who arranged the transmitting apparatus.

Mr. Robert F. Gowen at whose home the show was given, is the Chief Engineer of the DeForest Radio Telephone and Telegraph Co., which has a station at High Bridge, New York City, at which station Dr. Lee De Forest, the inventor, and a party of guests overheard the musical numbers and dialog of the entertainers.

Selected audiences in various cities in Connecticut, Ohio, Arkansas, Illinois, and Washington, D. C., also heard the show staged at Ossining, N. Y.



The Misses Rosetta and Vivian Duncan, from the New York Musical Comedy Success, "Tip Top," Gave a Song Review at the Residence of Robert F. Gowen, Ossining, N. Y., a Short Time Ago and the Concert Was Sent Out Thru Mr. Gowen's Wireless Telephone Apparatus and Picked Up By Amateur Radio Stations Hundreds of Miles Away.

Chicago High School Radio

The first messages ever sent by radio from one school to another, in line with the Board of Education plan to estab-

Radio Messages Were Recently Exchanged Between Chicago High Schools, in Which City the Board of Education Is Planning to Establish the Study of Wireless Telegraphy in the High School Curriculum.

lish wireless telegraph and telegraph outfits in

Chicago's high schools, were exchanged recently between the Lane Technical and Tilden High Schools of Chicago. Both telegraph and telephone messages were sent. The photograph shows members of the High School Radio Association getting a message at the Lane Technical School from the Tilden School. Those in the photo, from left to right, are Richard Rhodes, Herbert Moos, Carl Ulrich, President of the Association, and George Frost, Secretary.

Radio-telegraphy and telephony have been given such a distinct impetus thru the great organization activities of our army and navy in the World War, that many high schools thruout the country are encouraging the art by giving lectures from time to time as well as aiding in the installation of a station by the pupils.



A New Binding Post

In electrical work it is often seemingly little that makes a great difference in operation, and perfection in details has a great effect on the attainment of results. There is nothing more aggravating than a poor binding post. The new binding post which we illustrate presents various features of superiority; there is practically nothing about it to wear out; it will receive a wire and hold it firmly without marring it; and as regards its appearance the illustrations speak for themselves. These posts are particularly recommended where perfect connections which will resist vibration are to be made. The contact surfaces between which the wire is gript are practically the full width of the post, and the opposed faces, gripping the wires, are accurately parallel.

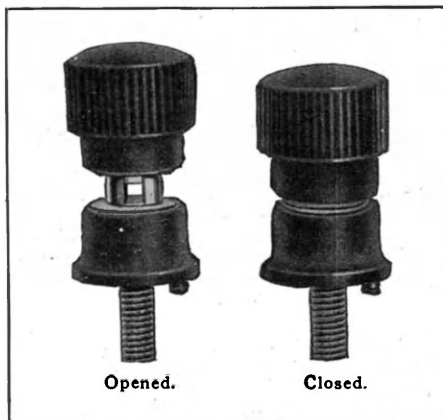

These binding posts are highly recommended for testing laboratories and in general wherever really good work is to be done. They are made in various sizes, the largest passing a 150 ampere current. Nothing is more aggravating than binding post troubles. Here we have an evident attempt to get rid of them.

Some radio experimenters have the habit of clamping the wire terminals to wood or other bases simply by curling the wire under a washer held down by a wood screw. Such connections are liable to give rise to an "open circuit" at any time, especially when a long distance record is sought by the radio experimenter. The use of suitable binding posts always pays in the end.

A Decremeter for the Amateur

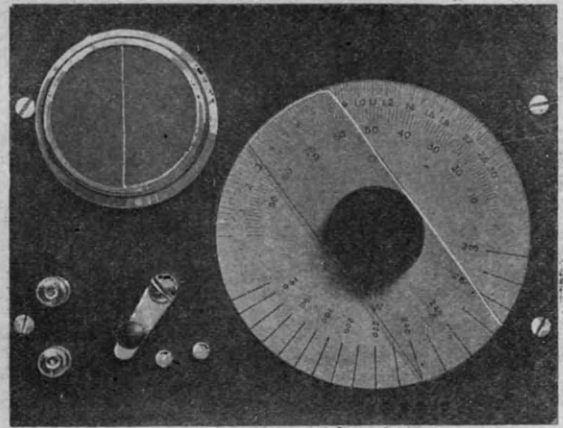
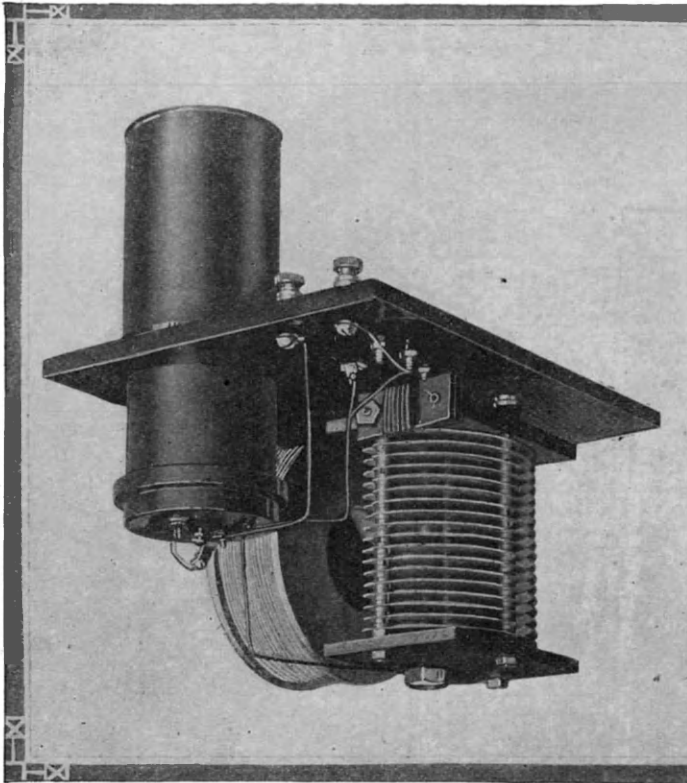

This New Decremeter Does Not Require a Hot-wire Meter, is Accurate and Solidly Constructed and Is Excellently Adapted to Amateur Needs. It Will Measure Both the Logarithmic Decrement and Wave Length, and Sells At But a Small Fraction of the Cost of Any Other Decremeter. It Is Provided With Two Small Incandescent Electric Light Bulbs Which Are Mounted at the Bottom of a Cylindrical Tube, the Upper End of Which Is Closed by a Frosted Screen. One of These Bulbs Is Lighted by the Current Induced in the Oscillatory Circuit of the Decremeter and the Other Is Lighted by Two Dry Cells. A Tubular Shield Is Provided Thru Which the Screen Can Be Viewed.

The measurement of the *logarithmic decrement* has always been the greatest obstacle in the way of proper tuning of the amateur radio transmitter. The delicacy of the hot-wire, current-squared meter used in the construction of decremeters, with its high cost, have placed the instrument entirely beyond the reach of the amateur.

The operation of the instrument is as follows: The Decremeter is first adjusted to perfect resonance with the antenna circuit as indicated by maximum illumination of the oscillatory circuit bulb. The coupling between the *decrometer* and the *transmitter* is then varied until the illumination produced on the screen by the two bulbs is equal. A resistance is now cut into the

battery circuit by throwing a switch, which reduces the current by a suitable predetermined fraction, and thereby reduces the illumination on the screen associated with the battery circuit bulb. The variable condenser of the decrometer is now rotated, first on one side of resonance and then on the other, until the illumination on the two halves of the screen is again equal, and the scale reading is taken in each position.

The difference between the two readings is the sum of the decrement of the circuit under measurement and that of the decrometer itself. The decrement of the decrometer is subtracted to obtain the final result. No complicated calculations of any kind are necessary. The measurement of the

logarithmic decrement has thus been reduced to its simplest possible terms, the total time required for making a measurement not exceeding one minute.

The United States laws governing radio-communication state that the logarithmic decrement shall not exceed two-tenths. Under these conditions it is actually possible to radiate more energy which is *effective in transmitting*, than with a broad wave of high decrement. A hot-wire ammeter in the antenna does not give a good indication of the effectiveness of a radio transmitter, because it does not distinguish between the condition where the energy is spread over a broad band of wave lengths and the condi-

(Continued on Page 84)

Compact Audion Control Unit

THE new vacuum tube control unit here illustrated embodies a new idea in design that may be classed as revolution-

ary. It makes the cumbersome and expensive cabinet type of control obsolete and is entirely replacing that type of apparatus.

It is much more compact and neater in appearance than many types of control panel.

It may be used with any tuner or receiver as a detector or oscillator, or, together with a suitable transformer, as an amplifier which can be used in connection with a crystal detector or another vacuum tube. The outfit

Neat and Efficient Audion Control Panel, Which Includes Rheostat, Grid Leak and Grid Condenser.

comprises a socket, mica grid condenser, grid, leak, rheostat and nine terminal posts moulded into a panel unit of black condensite.

The receptacle is designed for the standard four prong based detector, amplifier or transmitter tube. The shell is of nicked brass and projects thru the base panel. The tube contact springs in the rear of the socket are of phosphor bronze.

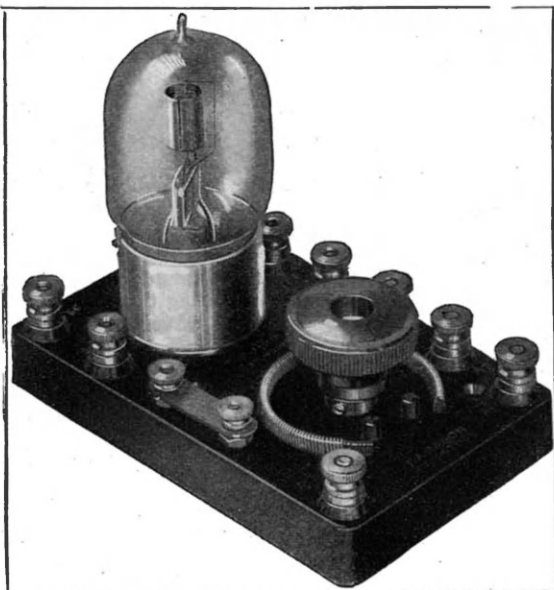

The Grid Condenser is exactly the right capacity. The conducting plates are brass and the dielectric is mica which simply means smaller losses than would be the case with a cheaper tin foil and paper condenser.

The Rheostat is superior in design and workmanship to any other intended for a similar purpose—the rheostat which has been adopted as standard for vacuum tube

(Continued on page 84)

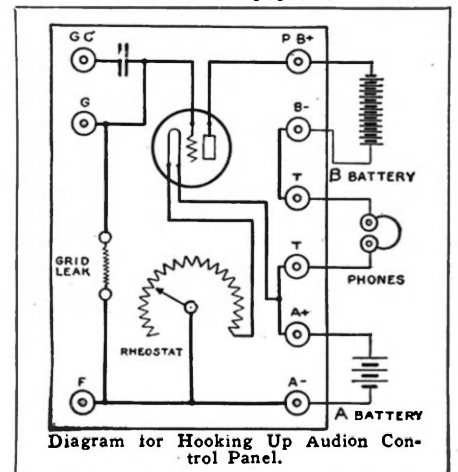



LATEST PATENTS



PATENT OFFICE
WASHINGTON

Moving Picture Camera

No. 1,363,249. (Issued to Fred N. Hallett.)

This invention provides for a moving picture camera that will take pictures

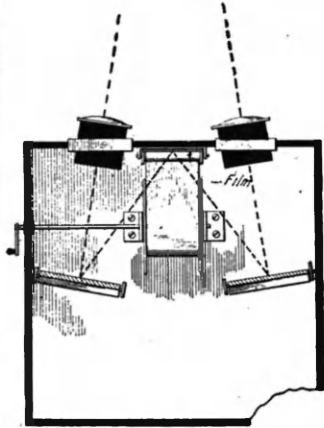

having a stereoscopic effect similar to that produced in the human eye. The camera is provided with two lenses spaced apart so that the images observed thru them will resemble the images formed in each of the human eyes. The light coming from an object strikes a mirror within the camera, which in turn reflects that light upon a sensitive film of the motion picture camera. Both images are reflected upon a single film over each other, and when projected are said to give the effect of solidity now lacking in modern films.

Automatic Eraser

(No. 1,363,848. Issued to Andres Ponce de Leon.)

An eraser is a necessity, particularly in large offices, but it is rather tire-

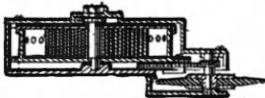

some to erase typewriting. The inventor has contrived a means whereby an eraser is mounted upon a small shaft connected directly thru the intermediary gears to a spring motor. The spring motor is wound up and a small button on the side releases it allowing a circular eraser to spin around. When placed in contact with the work the erasure is easily effected. In order to regulate the speed of rotation of the spinning eraser, a rubber friction pad is attached to the button governing the release mechanism which button if prest upon beyond the point of release, will retard the speed of the erasing element, due to its friction upon the drum encasing the spring.

Aircraft Launch-Way

(No. 1,363,539. Issued to Joseph A. Steinmetz.)

It frequently happens, particularly in flat country after or during a heavy rainfall, that the aviator is unable to leave the earth because he cannot obtain the necessary initial speed by a short quick run, even on regular aviation fields. Quicksands or common dry



sand areas often make landing and ascent impossible, as does snow, etc., therefore it has been proposed to equip such landing fields with wooden starting platforms. This, however, is only available on "permanent fields." The inventor of the device here described, presents a elongated net of somewhat close-meshed fabric preferably drawn very tight and secured to pegs, screws,

or the like for such landing stations. This net is stretched upon the ground and forms a very suitable landing surface. The net is equally effective on bogs and furrows, or on otherwise moderately rough ground, as well as on quicksand or snow.

Amusement Device

(No. 1,359,508. Issued to Owen Johnson.)

A very clever amusement feature which is simply an enlargement of a number of toys found on the market, is the idea of this invention. There is a circular car which is raised on an elevator to the top of a tower. Here it is released and fed to a run-way consisting of an inclined plane, which plane is divided into a plurality of squares full of pockets leading to passage ways beneath the surface. These passage ways also intercommunicate below the surface of the plane, so that the entrance of a car thru a particular pocket may not cause that car to emerge from a corresponding pocket as its gyrations below the surface are unknown to the bystanders. Poets or pins are disposed at intervals, upon the surface to deflect the cars, in case it is discovered that sufficient element of chance does not enter into the course of the car. The pins

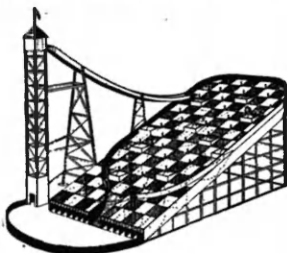

are removable and likewise prevent the cars from wearing any fixed pathway upon the board.

Fly Trap

(No. 1,359,796. Issued to Juan Ismael Dominguez.)

This is without a doubt, one of the cleverest devices yet patented for catching flies and other insect pests. Substantially, it consists of a rotating plate or disc provided with a series of

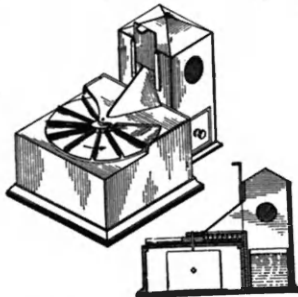

radial fins or webs which in succession pass below a cover of particular construction, which forms the trap proper. Between each of the webs of the plate, syrup or other suitable sweet is placed, adapted to attract flies and insects, inducing them to alight on the plate which by its slow rotation, carries the insects to a point where the said cover is situated. In order that the flies when entering beneath the cover, should not be alarmed by a sudden change of light, a part of the cover is made of glass. By this arrangement, when the flies know that something is wrong, they have already past below the glass and are trapped between the webs of the disc and the surface of the glass.

The flies are caught and moved slowly to the opening into the collecting compartment where a cone shaped funnel has its mouth. At a certain point, just past this collecting compartment, a series of combs or flaps disturb the flies, making them leave the rotating disc and fly into the collecting compartment, and light like-

wise assists them in determining an upward flight. Here they are caught and later they fall into a receptacle at the bottom adapted to contain water or some other fluid, where the dead flies accumulate and are afterwards thrown away.

Telephone Receiver

(No. 1,362,008. Issued to John C. Kane.)

This invention provides for an improvement in telephone receivers,

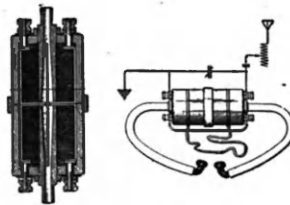

especially those used for radio work. It consists of a double electro-magnet, the core of which is of hardened steel, permanently magnetized so as to induce positive and negative poles in the interior ends towards the diafram, hence unlike permanent magnet poles will be adjacent. The coils are wound to a high resistance so that when current passes thru them they oppose each other, i. e., so that ends of like induced poles will be adjacent. A diafram is balanced between the poles which is vibrated by the current. By means of nuts, arranged on the outer end, the position of the poles with reference to the diafram may be adjusted. Flexible tubes leading from the poles are fitted to the ear pieces and the receiver itself is suspended from the neck of the user by means of a strap. Much stronger signals are claimed for this contrivance.

Flying Machine

(No. 1,364,174. Issued to Thomas Bird.)

In this flying machine the wings are



so arranged that when the motor is in operation a combination forward and backward oblong rotating movement is imparted to them. The positions of the wings relative to the machine, are controlled simultaneously. The wings are attached to rods which in turn communicate with an oblong cyclic channel. This channel consists of parallel-spaced channels connected at their ends by arcuate channels. With these combined movements the inventor claims to get the motion of the winged planes precisely as they are in the bird's own movements. The airplane wings being above the body, a parachute effect will be obtained and the machine will descend slowly and with safety, even if the engine is stopt.

Bicycle Motor Attachment

(No. 1,364,476. Issued to Ralph E. Bates.)

This invention is so well known that it

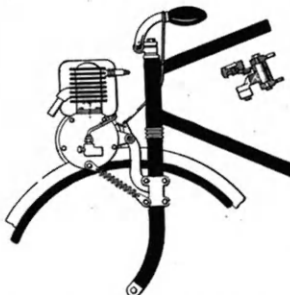

is hardly necessary to describe it. It consists of a two-cycle engine mounted on the fork of a bicycle frame in such a

manner that the crank goes on one side of the front wheel and the flywheel on the opposite side to preserve the balance. The concave frictional roller makes contact with the front wheel of the bicycle, causing, when the engine is running, the forward movement of the rider. Timing is effected by a connection on the fly wheel and regulated with reference to advancing or retarding by the rider thru one of the levers. The gas is likewise supplied thru a flexible connection.

Typewriter Paper Take-Up

(No. 1,364,103. Issued to Daniel Gardner.)

In this invention the patentee has indeed combined simplicity with novelty of ideas. As is well known, when using typewriting machines, particularly in work in which a number of sheets of paper and one or more sheets

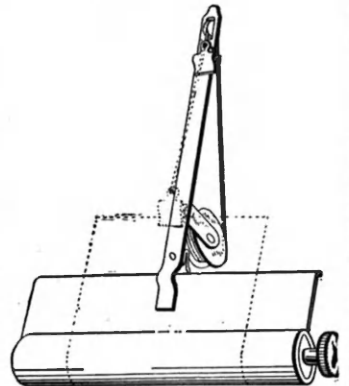

of carbon are placed in between the paper in the carriage, and fed up step-by-step by the line feeding mechanism, it frequently happens that an unequal feed of the sheets of the different layers or a twisting of the sheets, affecting the alignment of the work occurs. With this device the inventor fastens a light frame extending above the paper roll, to the typewriter, at the end of which is a spring drum. Attached to the spring drum is a flexible cord and paper clamp. The paper clamp engages the upper edges of the combined sheets of paper and as the paper is spaced vertically by the line feeding mechanism, the take up exerts an equal upward motion, preventing any movement of the sheets with respect to each other, or a tendency of one sheet to move faster than the next.

Flying Machine

(No. 1,364,752. Issued to John Hallstead.)

The inventor provides for a series of wings which are rotatably mounted and

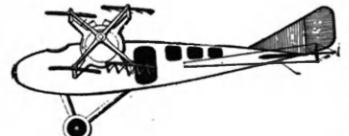

so adapted as to be moved by an engine whose shaft is transverse to the body of the plane. These wings are arranged in flap formation and suitable connection is provided to prevent the flaps from swinging forward. Due to the rotating action and to a system of levers which keep the planes at practically the same angle, the blades perform the function of first propelling the machine forward, the flaps acting on the air and pushing the plane ahead for the forward motion. The blades of the plane then move into the vertical position where no action takes place. Following this same blade around, we find it will move to the forward top-most position, here acting as a sustaining element, and in its course thru the other quarter of the circle, it acts as a lifting power for the airplane.

What to Invent

By JAY G. HOBSON

Mechanical Chiropractor

HERE are three distinct modes of healing the sick—three distinct professions taught by three individual schools. The old line medical college continues teaching the science of medicine and surgery. The new departure from medical practise is

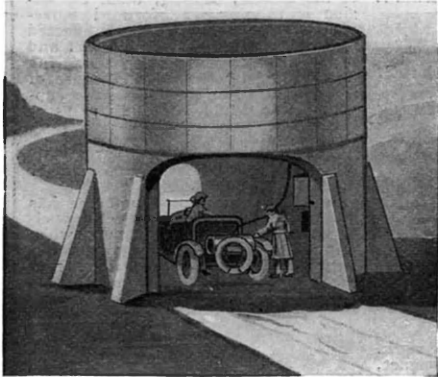

Why Don't We Find Automatic Self-Service Gasoline and Water Supply Stations Like This Along Our Highways?

known as osteopathy which is a drugless system of manipulatory therapeutics. There are about eight thousand practitioners of this system in the country today. Their practise is based upon the belief that all human ills originate in the nerve centers and the nerve fibers—that the body tissue dependent upon the nervous energy for health, often becomes diseased thru improper circulation and congestion caused by the pressure on the nerves feeding the tissues. Medicine and osteopathy treat the result of the disease. Medicine treats the affected part with drugs and serums. Osteopathy treats it in a drugless-way by adjustment of the whole body system of the body as far as requisite or possible. It is done by pretty vigorous treatment by the practitioner.

The third, and newest science of healing adjusts the cause of disease at the source or seat of the trouble, which they maintain is always to be found in the bony segments of the spine. This fast growing profession is very singular in application, as in results. Twenty-five years ago, Dr. D. D. Palmer of Davenport, Iowa, discovered an entirely different system of spinal adjustments for curing the deaf, which he called "Chiropractic," meaning adjusting something with the bare hands.

An old janitor in the building where Dr. Palmer had his office was very deaf and sought relief from his affliction, from Dr. Palmer, who examined the bony parts of his spine and found that several of the janitor's vertebrae were dislocated, causing pressure on the nerve trunks leading to the ear, originating from either extravasated blood or some inflammatory exudation

and in turn giving rise to this form of temporary deafness, which in turn caused the deafness. After a few adjustments were given to correct the unnatural position of the vertebrae, both the doctor and patient were agreeably surprised to find he could hear again.

This discovery was the start of the greatest profession known in the art of healing humanity. Dr. D. D. Palmer never lived to see the fruits of his invention fully mature, but his son, Dr. B. J. Palmer, has carried on the great work, which is presently recognized by twenty-six states, and numbers over thirteen thousand practitioners who give daily adjustments to over one-half million people having faith in the ability of chiropractic to effect a permanent cure.

Chiropractic science is based upon the belief that all sickness begins in the misplaced vertebrae pressing upon the nerves which pass thru the little openings on either side of the spinal bones. When the small openings become partly closed the vertebrae squeezes the nerves going to the various vital organs of the anatomy, and this pressure acts upon the flow of life-giving nervous energy, similar to the way pressure would act upon a rubber hose with water flowing thru it. The doctor of chiropractic adjusts the vertebrae, resetting the openings to their proper positions with his

like New York, Chicago and Philadelphia, woke up on a few occasions to find themselves deeply buried in a deluge of snow that stopped all business and seriously interfered with obtaining the necessities of life. The removal of the frozen vapor cost millions of dollars and untold suffering. Quite a number of suggestions and devices were offered the city fathers for cleaning the streets, but it seemed none were of any great importance. Now, during open weather is the time to get busy and invent an effective method, plan or system for keeping the streets and roads open for traffic. With a view to helping along this line I will outline below what I believe to be a novel and entirely practical scheme for overcoming the great snow problem.

My idea is simply the laying of steam pipes in the center and sides of the concrete streets, to be fed with steam by each office building, apartment, hotel and factory along the thoroughfare. These steam pipes to be laid in or under the streets and walks, and the heat to be turned on when it begins snowing so that the pavement will become sufficiently warm for the snow to melt and run into the sewer as fast as it falls. Each large building along the street could contribute its share of steam, which wouldn't cost them one fourth what it does to have the snow removed after it has packed before their doors. Having the pavements

warm would melt the snow as it falls and after the storm had subsided the streets would be as clean and clear as they are after April showers. This idea should be very feasible as demonstrated by dropping some ice cream on the hot pavement in the Summer time—it soon disappears. So would the snow vanish if the streets were heated enough to melt it.

Automatic Gasoline Filling Station

If you own a motor car or drive one you will readily appreciate the improvement needed in the present day gasoline filling

stations. The kind now in use are very (Continued on page 86)

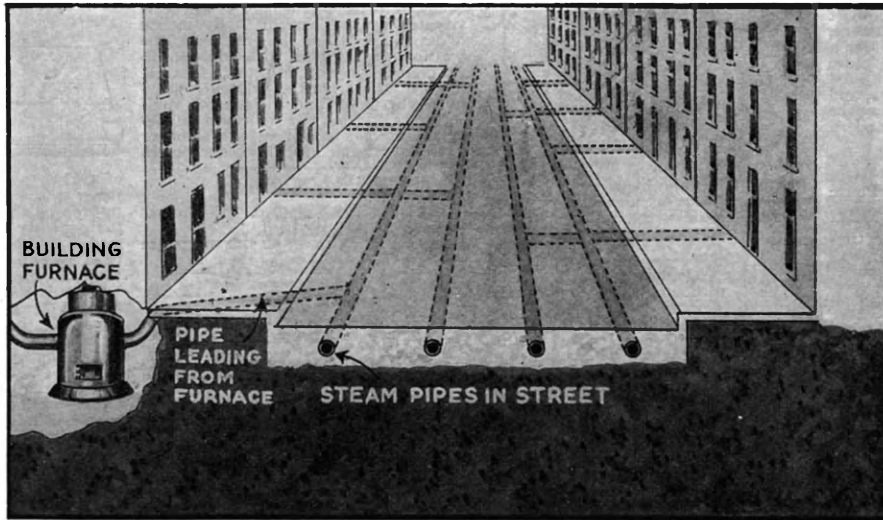

Mr. Hobson Here Suggests the Laying of Steam Pipes Just Under the Street's Surface to Melt Snow As Fast As It Falls.

bare hands, or in other words the bones of the spine are moved back into alignment, which allows the body to become healthy and young again.

Granting that the chiropractic theory is correct, I have often thought of the possibility of some genius devising a mechanical adjuster for the misplaced vertebrae, something in the form of a brace or cast that could be secured to the spine at night and during the relaxation of sleep, gently press the faulty bones into proper place. An X-ray picture could be taken of the spine to show the bones in need of adjustments, then the form or brace could be made so that it would exert sufficient pressure on the vertebrae needing attention to straighten them up properly. Of course the mechanical details of this device would have to be worked out to perfection, but here is the idea and it may be possible. The Roth orthopedic system is worked out along these lines.

Snow Melter

During the past winter several large cities

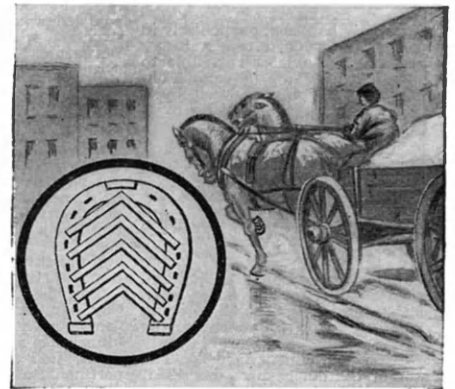

A Good Suggestion for An Improved "Ice Gripping" Horse Shoe.

Scientific Humor

Maybe He "Found" the Water Cold.
 —TEACHER—"What did Archimedes say when he stepped into his bath and it overflowed?"

SMALL BOY—"Eureka!"
 TEACHER—"What does Eureka mean?"
 SMALL BOY—"I have found it!"
 TEACHER—"What had he found?"
 No answer.
 TEACHER—"Surely you know that?"
 Still no answer.
 TEACHER (impatiently)—"Come boy what had he found?"
 SMALL BOY—"P-p-please sir, the soap"—*Thos. Elliott Scotland.*



not interested in microbes."

Heard Atome.—DAUGHTER: "Father, I want you to see my new dress."
 FATHER: (reading) "No, if it is as short as the others don't bother yourself, I'm not interested in microbes."
 —*A. R. Graham.*

The Real Attractions.—PROFESSOR (explaining magnetism)—"Jack how many natural magnets are known of?"

JACK—"Two, sir."
 PROFESSOR (surprised)—"Yes! and will you please name them."
 JACK—"Blondes and Brunettes, Sir."
 —*M. H. Wolf.*

Must Have Been a Leg-acy.—Johnnie was presented with a toy automobile for Xmas. One nice day while he was out riding in it, one of his boy friends saw him and said, "Gee Whiz! Johnnie, where did you get the swell automobile? Is it run by gasoline?"

JOHNNIE—"No, Leg-tricity."
 —*Eugene Hendricks.*
 (And most Flivvers have arm-strong self-starters. *Printers' Devil.*)



Some Hel-luva Fine Idea.—PROFESSOR (in science class)
 —"No doubt you have heard of the invention that Mr. Edison is now working on. Now who can tell me what great problem is involved in an apparatus for communicating with the dead?"

BRIGHT FRESHMAN—"Getting wire which will resist the heat!"
 —*Gerhard Ramberg.*

She Knew All About His "Venus."—"Mother," said the son, "I made a mistake when I selected chemistry. But it is not too late to change my course of study even now. I want to take astronomy instead."

The mother searched the eyes of her son sharply. Then she said: "No, You'll have to think up some better excuse for staying out at night!"—*Elmer Gosser.*

First Prize \$3.00

Better Contact Necessary.—

SAMBO: "Say Rastus, what would yo' all do if yo' honey wanted a kiss ovah de telephone?"
 RASTUS: "Ah'd ask fo' betta' connections."—*H. W. Cowen.*



Damming His River.—SCIENTIST: "What would you say if I told you that eventually all the rivers will dry up?"

CYNICS: "I'd say, do likewise."
 —*Wm. Paige.*

Nobody Home.—"Earnest," said the teacher of geography, "tell me what you know about the Mongolian Race."

"I wasn't there," explained Earnest hastily, "I went to the ball game."
 —*Clarence Deusch.*

WE receive daily from one to two hundred contributions to this department. Of these only one or two are available. We desire to publish only scientific humor and all contributions should be original if possible. Do not copy jokes from old books or other publications as they have little or no chance here. By scientific humor we mean only such jokes as contain something of a scientific nature. Note our prize winners. Write each joke on a separate sheet and sign your name and address to it. Write only on one side of sheet. No letters acknowledged unless postage is included.

All jokes published here are paid for at the rate of one dollar each, besides the first prize of three dollars for the best joke submitted each month. In the event that two people send in the same joke so as to "tie" for the prize, then the sum of three dollars in cash will be paid to each one.

So He Kissed Her On the "Spot."—JACK—"Do you object to kissing on sanitary grounds?"

JACKETTE—"Oh, no."
 JACK—"Then let's take a little stroll thru the infirmary."—*Alfred P. Dahl.*

Veloci-bee'd. — TEACHER: "Johnny, what is velocity?"

JOHNNY: "Velocity's what a fellow lets go of a bee with."—*John H. Schalek.*

A Correct Toe - Tal. — TEACHER: "Can anyone think of anything worse than a giraffe with a sore throat?"

PUPIL: "Please, sir, a centipede with corns on each toe."
 —*R. A. Jensen.*



We Saw Thru This One O. K.—CONTRIBUTOR: "The jokes I handed in were not published."

SCIENTIFIC JOKE EDITOR: "I know it. After this write them on tissue paper so I can see thru them."—*Carl Brecht, Jr.*

And Hogged the Road.—MRS. COMPLAIN—"John Henry, what's wrong with the car; it squeaks awful?"

HER HUSBAND—"Only natural my dear; they used pig iron in the axles."
 —*Ben Cool.*

That Took His Breath Away.—

It was a chemistry class, and the aged professor, who was anything but a light drinker, was doing a stock experiment, which consisted of blowing vigorously upon some blue crystals, whereupon they turned yellow.

When he had finished he asked the class if they had any questions to ask.

"Yes sir," came a voice from the back of the room. "Will anybody's breath do that?"—*Ben Cool.*



Enlightened.—"Astronomers are making an attempt to weigh light."

"That's easy; the grocers have been doing it for years."—*D. H. McFarland.*

He Must Be Board to Death.—HE—"Where does Sir Oliver Lodge?"

SHE—"Where Ouija Boards."
 —*Ivan Pechner.*

Some Frame-Up.—FELIX—"Are the pictures in the rogues gallery framed?"

EYEBAD—"Yes, in 'Guilt!'"
 —*Ivan Pechner.*

Ought to Go On Strike.—"I am no good unless I strike," said the match.

"And you lose your head every time you do strike," said the match box.
 —*Albert Dalstrom.*



Superior Force.—PROF. (in mechanics): "What is a couple?"

STUDENT: "Two equal parallel forces acting in the same direction."

PROF.: "But if they act in opposite directions?"

STUDENT: "That's a divorce case."
 —*J. L. Koble.*

Our Memory's Good, the Joke's Old.—PATIENT: "I wish to consult you with regard to my utter loss of memory."

DOCTOR: "Ah, Yes! Why—er—in cases of this nature, I always receive my fee in advance."—*Wm. Paige.*



THE ORACLE

The "Oracle" is for the sole benefit of all scientific experimenters. Questions will be answered here for the benefit of all, but only matter of sufficient interest will be published. Rules under which questions will be answered:

1. Only three questions can be submitted to be answered.
2. Only one side of sheet to be written on; matter must be typewritten or else written in ink, no penciled matter considered.
3. Sketches, diagrams, etc., must be on separate sheets. Questions address to this department cannot be answered by mail free of charge.

4. If a quick answer is desired by mail, a nominal charge of 25 cents is made for each question. If the questions entail considerable research work or intricate calculations a special rate will be charged. Correspondents will be informed as to the fee before such questions are answered.

Colored Aluminum Castings

(1092) Robert Winterhalter, Kamloops, B. C., Canada, writes the Oracle:

Q. How can I color aluminum castings?

A. 1. There are various ways of treating aluminum so that it will assume a different color. None of these are permanent, and, we doubt very much, whether you can obtain an absolute color, unless you form an alloy between two metals.

Thus, aluminum is greatly influenced by a proportionately small amount of copper. Alloys of 99 per cent. aluminum and 1 per cent. copper are hard, brittle, and bluish in color. With 80 per cent. and upward in copper alloys of aluminum, a beautiful yellow color is obtained.

Alloys of 5 per cent. to 10 per cent. aluminum and 90 per cent. copper are genuine aluminum bronzes. With cobalt and nickel a yellow alloy is produced. Easily fusible metal alloys with aluminum give white alloys.

Dynamo Brush Inquiry

(1093) Bill Andrews, St. Mary's, O., asks:

Q. 1. How many segments should the brushes of a generator cover? I am running a generator and it gets very hot all over. The segments are one-quarter inch apart and the brushes rest on four segments at once. Do you think that the brushes are too wide?

A. 1. Apparently your brushes are too wide. Your commutator segments are too many for one brush to cover. It should never cover more than three segments. We would recommend that you try varying your brushes until they only cover two to three segments.

Why Does Auto Run Up-hill Backward?

(1094) John Parker, New York, N. Y., asks:

Q. 1. I have noticed a number of cases where an automobile truck has been able to climb a steep hill by running up the hill backward, when it could not ascend the hill running in the normal forward direction. Several friends of mine have also had similar experiences, and I would like to know what the reason for this is.

A. 1. There is but one reason why this effect can occur in most cases, aside from the fact that once in a while the gasoline may be low in the tank and one finds that it will feed into the supply pipe when the machine is turned around. One reason why heavily loaded automobile trucks have from time to time been able to climb steep hills (when they could not climb up while running in the forward direction), lies in the fact that from mechanics we know that the power developed is equivalent to the speed in feet per minute multiplied by the pounds pressure or torque on the surface of the wheel. When the machine is turned around end-for-end, it is of course run up the hill on the reverse gear, and what happens in this case, is that the machine ascends the hill slower than when running in a forward direction, but simultaneously the torque developed in pounds on the rim of the driving wheels is greater.

Radio Wave Propagation

(1095) C. E. Marshall, Chicago, Ill., writes the Oracle:

Q. 1. There seems to be some hesitancy as to the medium thru which the messages go, when under the sea or thru the earth. When they go thru the air there seems to be no doubt; the ether medium of course.

Is it not a fact that the ether exists in and thru all the solids of the earth, that is, in the interstices between molecules, thru which the messages go, and while undisturbed by air currents or other similar influences the messages find a freer passage than thru the air.

A. 1. Replying to your query regarding the propagation of wireless energy, whether thru the earth or thru the air, we would say that while what you say is true with reference to the all-pervading ether existing in all solid bodies including the earth and principally and particularly in all interstices between molecules, this would have no bearing on the subject in question, it seems to us, as the air proper does not have any effect on the ether and the one exists independently of the other for all practical wireless considerations.

You will find a very interesting article along these lines in the April, 1919, number of SCIENCE AND INVENTION, in which Dr. De Forest, Dr. Austin and others discuss the wireless propagation theory

4 Kilowatt Voltage Raising Transformer

(1096) W. P. Avelly, Akron, Ohio, writes:

Q. 1. For data on 4 kilowatt transformer to raise line potential of 104 volts A. C. 60 cycles, to 110, 115 and 125 volts, to compensate for severe line drop of potential.

A. 1. Herewith is data on the construction of a transformer to carry a 4 K. W. load.

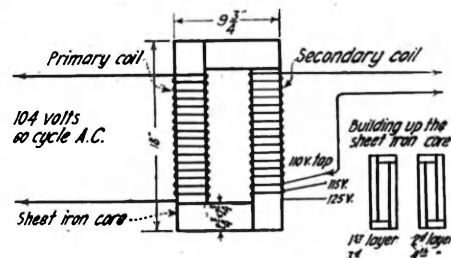

Data for 4 K. W. Transformer.

Length of rectangular iron core, 18 inches, width $9\frac{3}{4}$ inches, thickness and width of core section $2\frac{3}{4}$ inches, weight 91 lbs. Size of wire used on primary and secondary B. & S. No. 5, or two No. 8 wires joined in parallel. This wire is double cotton covered and wound on the core after the core has been thoroughly insulated with several thicknesses of Empire cloth and fish paper, 166 turns of wire are used on the primary. This is wound close together and when the winding is complete, several thickness of the best Empire cloth insulation are applied, on top of this a tube of fish paper, and then to further insulate it thoroughly, a layer of linen tape is applied, thoroughly shelled and wound very tightly.

The length of the winding on the primary is $11\frac{1}{2}$ inches, comprising approximately three layers of wire. Be sure to wind 166 turns. There are 214 feet of wire in the primary, weighing about 22 lbs.

For your secondary, 110 volts, the same size wire is wound on, all the dimensions are the same, excepting that the number of turns is 177. The winding is put on over the insulation on the primary. The secondary winding may be put on the second long leg of the transformer core, insulating it thoroughly first. A tap is now taken off. This is the 110 volt tap. Continue to wind until you have 184 turns. Then take off another tap. This will be your 115 volt tap. Winding until you have 200, take off a final tap, which will constitute the 125 volt mark. In other words the entire number of turns on the secondary is 200. The number of amperes in the primary is about 36.4 at full load.

Acoustic Transmission Thru Pipes

(1097) W. I. Smith, Stockton, Kan., asks:

Q. 1. I want to conduct, or transmit, sounds from a bell thru a pipe about 1000 feet long, without the use of electricity. I thought of placing a bell in a tight compartment (with concave end to reflect sound waves) at one end of pipe. I particularly want to know about what per cent of loss of sound there will be in passing thru this length of pipe, and if 2" would be preferable to 1" pipe. If any turns are to be made in pipe they will be gradual and not sharp turns.

Q. 2. Could a diaphragm or amplifier, of cheap construction, be used in this pipe in order to keep the sounds full value or build them up stronger, and if so will you kindly give instructions how they would be made and where placed to get desired results, or where they could be purchased. As stated above no electricity is to be used.

A. 1. We regret our inability to state what the percentage of loss of sound would be in passing thru the pipe. It would be better to use a two-inch pipe for this experiment.

A. 2. We do not know of any efficient diaphragm which would work effectively without the use of electricity. But if you could use two or three ordinary dry cells, then we can recommend a telephonic "loud talker."

Size of Fuses for A.C. Motor

(1098) F. Stephenson, Bentleyville, Pa., asks:

Q. 1. Why is it that a fuse of larger capacity is necessary on a three horsepower, 110 Volt A.C. induction motor than a three horsepower 110 Volt D.C. motor; the A.C. motor taking about a 60 ampere fuse?

A. 1. The reason for this is that the maximum value of the square root of the mean square value of the current is very large at the start.

Ultra-Violet Rays

(1099) Clyde Schroeder, Bartlesville, Okla., asks

for the distinguishing properties of ultra-violet light:

- A. Some of the properties of ultra-violet light are:
- 1—The effect of the ray is to render the air conductive.
 - 2—It makes many substances fluoresce.
 - 3—The rays may be reflected, nickel being about the best reflector.
 - 4—They are invisible to the naked eye, but affect a photographic plate.
 - 5—They may be produced by the quartz tube mercury arc.

Storage Battery Data

(1100) Aldred Hodges, Alma, Montana, asks:

Q. 1. Give me a short history of the storage battery.

Q. 2. The difference between Planté and Faure batteries as regards to efficiency.

A. 1. The principle of the storage battery was discovered as early as 1802 by Gautherot, who noted that two platinum wires, immersed in acidulated water when connected to current terminals later upon removal of the current supply, showed marked signs of polarity, hence "giving" current. Then after this discovery nothing further was done until Planté invented a storage cell consisting of two lead strips immersed in dilute sulphuric acid. He found that by giving this cell a long charge in one direction and then in the opposite direction its capacity was considerably increased. Faure is credited with the pasted plate.

A. 2. At the present time the Planté battery is made by preparing a pure lead plate with a large superficial area exposed and oxidizing its surface electrolytically so that it is covered with lead-oxide. This is a positive plate. The negative plate is formed likewise by a reversal of the current when that plate is a metallic sponge. The Planté type is used chiefly where weight and space are of no importance.

Its ampere-hour output is inferior to that of the pasted plate for each square foot of positive surface.

Removing Hair by Electricity

(1101) W. S. Hammond, Pittsburg, Pa., writes:

Q. 1. Give me some information on the removal of hairs by electricity.

A. 1. The removal of superfluous hairs by means of electric needle is done as follows: The positive electrode is held in the patient's hand; the negative or needle electrode is then inserted in the hair follicle and the current is gradually increased thru a rheostat. A pricking sensation will be felt and a very slight exudate of gas and a white liquid, ever so minute in quantity, will be seen at the base of the hair.

The hair can then be removed without pain, and it will never return.

Windmill to Drive 6 Volt Dynamo

(1102) M. Harrigan, Halifax, N. S., asks for:

Q. 1. The dimensions of a windmill to drive a Knapp 6 volt motor.

A. 1. A windmill composed of 6 blades 6 ft. in diameter will be large enough to drive a Knapp 6 volt dynamo. This dynamo at its highest speed generates from 30 to 36 watts and requires a 1/10 H. P. windmill to operate it.

This windmill with a 6 ft. fan develops 1/10 H. P. in a 16-mile wind.

Was \$100
 Before the War
Now \$64

SAVE
\$36

FREE TRIAL
Easy Payments

In these days when the cost of many things is higher than before the war, it is a distinct contribution to business-economy to offer through more direct selling methods such a great and decided saving on so popular a typewriter as the Oliver.



A Finer Typewriter at a Fair Price

Over 900,000 Sold

Send No Money!

No money in advance. Not a cent! Simply make your request via the coupon below if you want this brand new Oliver Typewriter for five days free trial in your own home or office. Use this Oliver for five days as if it were your own. Type all your letters or any other work with it. Put it to every conceivable test. Compare it with any \$100 typewriter on the market. Compare it for simplicity of construction. For beauty of finish. For ease of operation. For speed. For neatness of work. Then

if after 5 days free trial you do not wish to keep the typewriter for any reason whatsoever, simply send it back to us and you won't be out one cent for the free trial. If, on the other hand, you decide that it is the finest typewriter, and you wish to keep it, then pay us at the easy rate of only \$4 a month. This is the open, free trial offer we make to you on the Oliver to let you see for yourself that if any typewriter is worth \$100 it is this splendid, speedy Oliver No. 9, our latest model and the finest we ever built.

Famous Users of the Oliver

- Columbia Graphophone Co.
- Otis Elevator Company
- National City Bank of N. Y.
- Boston Elevated Railway
- Hart, Schaffner & Marx
- U. S. Steel Corporation
- New York Edison Company
- American Bridge Company
- National Cloak & Suit Co.

Save \$36 For \$64 you can now obtain the identical Oliver Typewriter formerly priced at \$100. We are able to save you nearly half because of our radically new and economical method of distribution. During the war we learned many lessons. We found that it was unnecessary to have such a vast number of traveling salesmen and so many expensive branch houses throughout the country. We were able to discontinue many other superfluous sales methods. Result—we can afford to sell at \$64 the very same Oliver formerly priced at \$100.

Mail the Coupon Now

Check the coupon to get the Oliver for five days free trial in your own home. If you decide to keep the typewriter you can pay for it on terms so easy that you won't miss the money—only \$4 a month. If you prefer to have further information before ordering, fill in the coupon for our free catalog. Avoid disappointment—order now to secure immediate delivery.

Canadian Price, \$82

The OLIVER
 Typewriter Company
 675 Oliver Typewriter Bldg., Chicago, Ill.

THE OLIVER TYPEWRITER COMPANY
 675 Oliver Typewriter Bldg., Chicago, Ill.

Ship me a new Oliver Nine for five days free inspection. If I keep it, I will pay \$64 at the rate of \$4 per month. The title to remain in you until fully paid for.

My shipping point is..... This does not place me under any obligation to buy. If I choose to return the Oliver, I will ship it back at your expense at the end of five days.

Do not send a machine until I order it. Mail me your book—"The High Cost of Typewriters—The Reason and the Remedy," your de luxe catalog and further information.

Name

Street Address

City..... State.....

Occupation or Business.....



Do you want this course in Boxing, Jiu Jitsu and Wrestling on Free Approval?

You can learn boxing and self-defense right at your own home by mail—we will send our complete "shortcut" Course on free approval without any deposit whatever, and prove this.

In a few lessons you will be hitting blows with the weight of the body behind them—the Bonnie Leonard Triple, the Jack Dempsey Triple, the Fitzsimmons Shift, etc. You will be able to duck, feint, clinch, side-step, etc., with professional skill. If there is a single statement in the preceding paragraphs that is not correct, you can return the books and end the matter. If you want to keep the course, you have till the 15th of next month to pay only \$5 (Canada \$6; foreign countries \$7).

Marshall Stillman is the first man to successfully teach boxing by mail. He starts you with movements you are already familiar with and gradually leads you into similar movements in boxing. Next, he teaches you 15 Jiu-Jitsu and bone-breaking holds and 14 holds in wrestling, for protection against violent attack. Then he gives you three rounds of shadow boxing and a set of muscle-building exercises, including Synthetic Breathing, for the lungs, the Colon Exercise (good for constipation) and rules for diet, training, etc. We will also send without extra charge a History of 69 Great Boxers, describing their favorite blows and telling inside stories not generally known outside of professional circles.

Send No Money
You cannot doubt what we say when we take all the risk of proving it. The question really is whether you want to be able to play a man's part if called upon,—or pass the buck.

Mail this Coupon

Marshall Stillman Association
Suite E-205, 461 Fourth Ave., New York

You may send me for free examination the complete Marshall Stillman Course in Boxing and Self-Defense, including extra instruction described above. I give you my pledge that you may feel safe in trusting me as agreed, and I will either return the course in ten days or pay for it on the 15th of the following month—price \$5 (Canada \$6; other countries \$7).

Name.....

Address.....

EASY To Play To Pay



BUESCHER

(None genuine without this trademark)

True-Tone Saxophone

A Buescher True-Tone Saxophone opens the way for you to greatly increase your income, opportunities, popularity and pleasure. Easiest of all wind instruments to play—you can learn to play the scale in an hour and in a few days be playing popular airs. Practice is a pleasure.

Saxophone Book Free Tells you when to use Saxophone—singly, in sextettes, or in regular band; how to transpose cello parts in orchestra and many other things you would like to know.

Free Trial You can order any Buescher instrument perfectly satisfied, pay for it on easy payments to suit your convenience. Mention the instrument interested in and a complete catalog will be mailed free. (36)

BUESCHER BAND INSTRUMENT CO.
Makers of Everything in Band and Orchestra Instruments
6026 Buescher Block, Elkhart, Indiana

To Raise Sunken Ships in 24 Hours

(Continued from page 16)

Vito twin submersible salvaging apparatus, in raising a sunken ship. The model of the steamship shown and used by this Boston engineer in demonstrating the stability and powerful lifting qualities of his machine, measures about 7 feet long and weighs, when loaded with pig iron, about 350 pounds. The steel guiding column is first lowered by being slowly filled with water to make it sink.

Each pontoon of the De Vito salvager is divided into a large number of separate compartments, any one or a group of which may be quickly flooded or emptied by means of compressed air to blow out the water in a very short time.

By having this accurate control of the flooding or emptying of the various compartments of the pontoons as well as the special balancing tanks mounted on the forward deck of the submersible, it is seen that the inventor has provided a means for quickly and reliably submerging or causing to rise, either end of the submersible pontoons.

The diagram shows, by means of dotted lines, the successive positions taken by the twin submersible both while submerging, as well as when raising the wrecked ship. This operation might be thought to require considerable time but in a special interview with Mr. De Vito, it seemed that his claims of raising any ship in 24 hours (this of course within the working range of the apparatus as he has conceived and designed it, that is, to attempt the raising of a sunken ship in a depth of 350 feet or less) would seem to be feasible and possible.

There are many questions which cannot be answered here, but which we asked Mr. De Vito, one of which was, for example, the effect of the strain or pressure on his pontoons when raising a ship; that is, the water pressure, for instance, at a depth of 350 feet which is about 150 pounds per square inch. One of the interesting engineering points we wish to mention at this point, and in favor of the De Vito apparatus, is that there is never any strain on the steel shell of his pontoons, created by hydrostatic forces, at any depth of water, because when the pontoons are lowered into the sea the sea valves opening into the various pontoon compartments are always open. The compartments are not simply filled with air and subjected to a strain of water pressing on the shells of the pontoons; but when the pontoon is being submerged, the valves are opened so as to sink it, and the water entering into the pontoon chamber equalizes its own pressure in view of the fact that the valves are open.

When the pontoons are to be raised the other phase of this problem appears, one which involves a disadvantage in many salvage machines. In the De Vito scheme, the water pressure on the shells of the pontoons at such a depth as at 350 feet (when the ship is to be lifted) is counterbalanced by the air pressure within any pontoon compartment, when the water is blown out with compressed air. This air is led down into the pontoons thru steel armored tubes from the compressors on the surface craft. Thus we see that there is no strain put up on the wall of the pontoon either when the valves are opened and the compartment flooded with water, nor again when the various pontoon sections are successively made buoyant by blowing out the water in them by means of compressed air, the air pressure being kept at suitable pressure, as indicated by gages on the surface, to counterbalance the water pressure, and thus keep the compartments both free of water as well as buoyant.

Mr. De Vito, who has had long experience in maritime matters, has, to our minds, de-

vised a very logical and sound design of salvaging machine, in fact, one of the very best we have ever seen so far. One of the excellent engineering points which he stuck to and which is in line with the arguments advanced by naval experts, is the absolute elimination of any intricate electrical apparatus to be operated under water, which is one of the strong points emphasized by many salvaging machine designers.

The working apparatus, located under water, of the De Vito machine is all subject to sturdy and rugged design, while the control of these parts is accomplished by very

(Continued on page 58)

Automotive Wiring Manual

Makes the wiring of any car or truck from 1912 to date as clear as an open book. Contains over 900 blueprints 9x11 inches, including internal connections of all Generators, Motors, Regulators, etc. First and only blueprint wiring book on market.

Pays for itself on first few jobs. All diagrams guaranteed accurate and authentic.

SENT POSTPAID FOR \$15.00
Live Agents Wanted. Write for details

AUTOMOTIVE PUBLISHING COMPANY
1370 Monon Building
Chicago - Illinois

NEW RUBBER TIRES TREAD TIRES

Exceptional quality of high grade reconstructed tires—Built for 6,000 Miles Service. All with genuine Goodyear Miller and Firestone new Treads bought direct from the factories at standard prices. Do not confuse these standard high grade tread tires with sewed or patched ones. Our special high pressure steam curing process gives new long mileage service and new appearance.

SEND NO MONEY

Pay only after examination at express office. Unwrapped section for inspection. After examination, if you are not fully satisfied with transmission handle valve return shipment and we will refund your money.

28 x 3	\$ 5.00	32 x 4 1/2	\$13.50
30 x 3	5.40	32 x 4 3/4	14.25
30 x 3 1/2	9.50	34 x 4 1/2	14.75
32 x 3 1/2	10.50	38 x 4 1/2	15.00
31 x 4	11.10	36 x 4 1/2	16.25
32 x 4	12.50	32 x 5	16.75
32 x 4	12.90	33 x 5	17.50
34 x 4	13.25	37 x 5	17.75

Standard-Make Tube

FREE WITH EACH TIRE

Send a today. Just get your name and number of tires you want. Be sure to state the size and whether S.S. or C.L. are wanted. If full cash sent with order deduct 5%. Read local newspaper advertisement.
MILBORN TIRE CORPORATION
Peoria and Harrison Sts. 162-A Chicago, Ill.

\$100 A WEEK AND MORE FOR YOU!

Chas. Evans, carpenter, of Ind., earned \$100 weekly last year. Gibbard of Mich. did \$60,000 business in 1920. Others had sensational records. All did it with Haywood's Tire Surgery. Twelve years ago I began with \$100 and new tire repair idea. Now own \$400,000 business. I've started hundreds of men from all walks of life—without experience—with very little capital—on same road to financial success. Let me start YOU. Write today. M. Haywood, Pres.
HAYWOOD TIRE & EQUIPMENT CO.
1209 Capital Avenue Indianapolis, Indiana

Standard Underwoods

5-Year Guarantee

Yes, this genuine Standard Visible Writing Underwood newly rebuilt, at much less than factory price, yours for \$3.00 down and then easy monthly payments.

\$3.00 DOWN

10 Days FREE Trial
Try it for 10 days at your risk. Money back guarantee. Send now for free book Big bargain offer.

TYPEWRITER EMPORIUM 2165 Shipman Building
Montrose and Ravenswood Avenues Chicago, Illinois

CLIP THIS COUPON



Chicago Technical College
 545 Chicago "Tech" Bldg.
 Chicago, Illinois

Without obligation on my part, please send, free and postpaid, instructions on how I can become an expert in subject marked below.

Architectural Drafting Machine Drafting Electrical Drafting Structural Drafting Sheet Metal Drafting Topographic Drafting Surveying Designing Contracting—Buildings	Auto. Engineering Aero. Engineering Gas Engines Plan Reading—Buildings Estimating—Buildings Plan Reading—Machinery Plumbing—Estimating, Etc. Heating and Ventilating Steam Engineering
---	--

Name.....
 Address.....
 Post Office.....
 College or Home Study. State which..... State.....
 Free Lesson when inquiry is for Draftsmanship or Plan Reading.

Learn Draftsmanship At Home

GET the facts about the Chicago "Tech" courses in Draftsmanship (or any of the other big paying professions listed on the coupon) which you can master quickly by spare time study at home. Salaries paid draftsmen today are the highest in history because trained men are scarce. Not enough to go around and hundreds of big jobs waiting. Industries of all kinds—manufacturers, architects, railroads, electrical plants, etc.—need pro-

ficient men for their drafting departments. Experts in this profession earn \$60 to \$150 weekly.

No matter what you are doing, this is your big chance. We will send you without obligation or expense a Free Test Lesson (read details of this liberal offer below). See how well qualified you are before you spend a cent. Look into these opportunities today. Learn how a Chicago "Tech" course will make you the man chosen from among many. Clip that coupon—NOW!

Experts Teach You the Methods They Use

The Chicago "Tech" method trains you under experts who will equip you for an important position in the shortest practicable time. You learn exactly the methods which they themselves use in their own practical work. They prepare you to rank with draftsmen of long experience. They give you the training required in men who aim to hold important executive positions and draw high salaries for their expert advice and service.

Why plod along and be content to take orders from men who know the "Hows" and "Whys" of a big job? You have it in you to give orders, once your trained knowledge gives you the confidence to assume charge of the men who do the actual work. The training in Draftsmanship which you get from Chicago "Tech" experts fits you to step right out and earn a big salary. You do not need to resort to guess work. Nothing can halt you—for you will KNOW your subject.



Send **FREE** Test for **FREE** Lesson

Shows you how well qualified you are for draftsmanship. Other schools ask you to enroll and send money first. We send the free lesson first. Read it—practice the exercises—no obligation. Decide for yourself whether you want to take the course or not.

FREE OUTFIT

With our home study course is included a complete set of high grade instruments, drawing board, T-square, etc. Same as leading draftsmen use. Credit given if you already have an outfit.

18 Practical Courses You Can Master Quickly

If you want to take up and master quickly any other technical study, the coupon above lists a number of professions that pay handsome salaries. If you cannot come to the college, you will get the same course—the same thorough individual instruction by mail. No matter where you live, your lessons are directed and every exercise examined and corrected by experts. Every point is made clear. You progress as quickly as your work proves that you have mastered each lesson.

No matter which course you decide to take, you learn just what you need to know from practical men who familiarize you with the things that make you worth a large salary. With the practical knowledge gained from a Chicago "Tech" course, you will be the man wanted—the man who is pushed ahead, because you know why things should be done and how to do them. You can start at a good salary and win quick promotion.

Decide Today—Then ACT

Now is the time to get the facts about any one of these Chicago "Tech" courses. Find out how hundreds of ambitious men have paved the way to high positions merely by using their spare time to prepare for bigger work. Just put X in the square on the coupon opposite the course you want to know about—sign and mail the coupon. This information costs you nothing—so Act Today.

Chicago Technical College 545 Chicago Tech Building
 CHICAGO, ILLINOIS

CLIP THE COUPON NOW



DEAF?

Here's Free Proof That You Can Hear!

The wonderful, Improved Acousticon has now enabled more than 400,000 deaf people to hear. We are sure it will do the same for you; are so absolutely certain of it that we are eager to send you the

1921 Acousticon
For 10 Days' FREE TRIAL
No Deposit—No Expense

There is nothing you will have to do but ask for your free trial. No money to pay, no red tape, no reservation to this offer. Our confidence in the present Acousticon is so complete that we will gladly take all the risk in proving, beyond any doubt, that the

Joy of Hearing Can Be Yours Again!
The new Acousticon has improvements and patented features which cannot be duplicated, so no matter what you have ever tried, just ask for a free trial of the New Acousticon. You'll get it promptly, and if it doesn't make you hear, return it and you will owe us nothing—not one cent.

Dictograph Products Corp.
1455 Candler Bldg. New York City, N. Y.



Ride and Sell Black Beauty Bicycles

—the bicycle with the biggest reputation for easy riding, good looks and good solid wear. This wonderful wheel with 18 exclusive features—

From Factory to You—FREE

We'll ship on approval—express prepaid. Look the wheel over before you pay a cent. You're sure to be enthusiastic when you see the wonderful 1921 Model Electrically Equipped

BLACK BEAUTY

Our direct-from-factory-to-you-price saves you money. A small deposit and **A DOLLAR A WEEK**—the wheel is yours with the first payment. Don't delay—write now.

Haverford Cycle Company
Dept. 625 (Est. 25 years) Philadelphia, Pa.
Be a Black Beauty Owner Agent



Learn to Dance

You can learn Fox-Trot, One-Step, Two-Step, Waits and latest "up-to-the-minute" society dances in your own home by the wonderful **Peak System of Mail Instruction**.
New Diagram Method. Easily learned; no music needed; thousands taught successfully; success absolutely guaranteed.

Write for Special Terms. Send today for FREE information and surprisingly low offer.
WILLIAM CHANDLER PEAK, M. S.
Box 245 4737 Broadway, Chicago, Ill.



SAVE 25% to 60%

on slightly used **GRAFLEX-KODAKS**

Cameras and Lenses of every description. Equal to new. Save money. Write now for **Free Bargain Book and Catalog** listing hundreds of money-saving bargains. An slightly used and new cameras and supplies. All goods sold on 10 days' Free Trial. Money back if not satisfied. You take no chances dealing with us. We have been in the photographic business over 16 years. Write now.

CENTRAL CAMERA CO., Dept. 115 124 S. Wabash, Chicago



Learn Autos and Tractors

Wonderful opportunities constantly offered trained men; we train you thoroughly to start your own business or make good money as motor expert, driver, shop foreman, etc.

5000 Graduates making good. Catalog Free.

Cleveland Automobile School, 1807 E. 24th St., Cleveland, O

To Raise Sunken Ships in 24 Hours

(Continued from page 56)

simple and reliable methods, such as by compressed air carried in flexible steel conduits, and other work under water is carried on by hydrostatic means.

An important point to mention perhaps, is that the twin submersible raises the wreck, not in the usual horizontal and easily capsizable position, but stern first and then the bow. This creates a situation whereby the ship being raised might easily slide downward and smash thru the end of the twin submersible salvager; but passing around the bow of the wreck is a gigantic chain or several if necessary, which are automatically tightened up by hydrostatic cylinders when the wreck starts to rise and thus checks any downward pressure caused by the ship attempting to slide forward or downward, as the stern is raised.

The reason why the stern is raised first, as explained by Mr. De Vito, was for the logical reason known to every "swimming hole" devotee, that, when any floating member such as the pontoons in this case, is allowed to draw one end above the surface of the water, it will act like a fulcrum or pivot and greatly stabilize the member during further operations while the bow is being raised. The stern is raised first by blowing the water out of the stern compartments in the pontoons. It is intended that when a ship has been raised, it can be in most cases, quickly repaired with the aid of divers using the regular appliances and by lowering collision mats, over the outside, so that it can either be towed to port or else sent to port under its own power. When the ship has been repaired so as to float satisfactorily, one end of the twin submersible is lowered as our diagram shows, and the steamship allowed to pass out.

All successful operations of the usual nature, carried out during the past several years, have been on vessels of minor tonnage and only on those that were at working depth. Working depths for divers normally terminate at about 90 feet. Beyond this, salvage companies do not ask nor do they expect divers to perform any manual labor. And without manual labor no vessel can be raised by present day methods.

In shallow waters on account of the lesser pressures, the diver's rubber suit is correspondingly pliable and affords him a certain freedom of action, but, all physical action is denied him in depths of 100 feet and over, when the air pressure required for the safety of the diver makes his suit extremely rigid, and because of the great pressure required by him below working depths the air affects his entire system, and places a severe stress upon the heart. Under such conditions the slightest exertion courts disaster. Weeks, and sometimes months are consumed in one wrecking operation, necessitating the employment of a great number of men and numerous divers. Under such circumstances, the overhead is tremendous and the outcome a gamble. The salvage engineer heretofore, has had to depend wholly upon the intelligence and handicapped perseverance of his divers. The twin submersible salvager requires no divers at depths where the outline of the sunken vessel is visible from the surface. At all other depths diving bells may be advantageously employed, but for observation purposes only.

About eight thousand (8,000) vessels valued at seven billions of dollars were sunk by submarines in the World War and thousands upon thousands of others were sunk in the seven seas during the last 100 years. Many of them went down with cargoes mounting up into the millions. The greater number of all sunken vessels now rest in depths of less than 350 feet.

BE AN ARTIST



CHECK FROM MAGAZINE

DRAWN BY 14-YEAR-OLD BOY

The above cartoon was drawn by Master Bob Brennan of the Washington School of Art. Bob writes that he is selling his work and that he is cartoonist on a small paper in Evansville, Ind. He is but one of our many students and graduates who are making money as cartoonists, illustrators and designers.

Learn By Mail at Home!

By our new method of teaching drawing by mail you can learn in your own home, in a short time. Get into this fascinating work yourself and earn \$50 to \$100 or more per week! The study is fascinating. Only a few minutes a day! Have your own studio or secure high-salaried position. Or work in spare time. Many students earn while they are learning.

FREE! BOOK AND ARTISTS' OUTFIT! WRITE TODAY

A complete outfit free to all students. Includes everything required to produce hundreds of dollars' worth of pictures. Write today. Special terms to a limited number of new students. Mail postal or letter for beautiful Booklet, "How to Become an Artist," filled with drawings and full particulars of our extraordinary offer. Do it now—before you forget.

WASHINGTON SCHOOL OF ART, Inc.
Room 1623, Marden Bldg., Washington, D. C.

6000 MILE CORD SERVICE TIRES



Sensational sale of high grade, reconstructed tires. These cord service tires are heavily reinforced with genuine new Miller (made to the road) treads as illustrated. Bought direct from factory at smashed prices, and guaranteed for 6000 miles. Do not refuse with no called patched or double tread tires.

Send No Money

Pay only after examination at express office. Unwrapped section for inspection. If not fully satisfied, with the tremendous bargain value, return shipment and we will refund your money promptly.

28x3	\$ 7.90	32x4	\$13.50
30x3	8.25	33x4	14.25
30x3 1/2	9.45	34x4	14.75
32x3 1/2	10.25	35x4	15.80
31x4	11.10	36x4	16.00
32x4	12.35	33x5	16.50
33x4	12.75	35x5	17.00
34x4	13.00	37x5	17.50

Standard-make TUBE FREE

With each tire ordered Write today. Be sure to state the size and whether S. S. or G. L. are wanted. Deduct 5 per cent if full cash with order. Send no money.

Eastern Rubber Co., Dept. 28B, 531 S. Peoria St., Chicago



\$2.63 **\$3.25**

SEND NO MONEY

To prove our blue-white MEXICAN DIAMOND closely resembles genuine diamond with same DAZZLING RAINBOW FIRE, we will send a selected 1 carat gem in Ladies Solitaire Ring (Cat. Price \$4.98) for Mail Price is introduced. \$2.63, or in Gents Heavy Tooth Belcher Ring (Cat. price \$6.25) for \$3.25. Our finest 12k Gold filled mounting. **GUARANTEED 20 YEARS. SEND NO MONEY.** Just mail postcard or this ad. State Size. We will mail at once C. D. If not pleased return in 2 days for money back less handling charge. Write for Free Catalog. Agents Wanted.

MEXICAN DIAMOND IMPORTING CO., Dept. F 1 Las Cruces, N. Mex.
(Exclusive controllers Mexican Diamonds)

STAMMER

If you stammer attend no stammering school till you get my large FREE book entitled "STAMMERING, Its Origin and the Advanced Natural Method of Cure." Ask for special tuition rate and a FREE copy of "The Natural Speech Magazine." Largest and best school for stammerers in the world. Write today. The North-Western School, 2331 Grand Ave. Milwaukee, Wis.

Learn the Auto and Tractor Business In Detroit the Auto Center



START A BUSINESS OF YOUR OWN

Thousands of openings await you. Think of the repair work necessary, think of the batteries and electric systems to be maintained, on the nine and a quarter million cars now in use. Splendid opportunities everywhere to start a garage, repair shop or service station of your own. Production is again increasing and trained men are moving forward.

Come to Detroit, the heart of the automotive industry, and learn the business at the M. S. A. S., the factory-endorsed school. This is the Right Way to Get Into the Auto and Tractor Business.

If you get this right start you can go just as far in this business as you have a mind to—there is no limit to the success you can make.

Detroit the Auto Center in Summer
There are many advantages in coming to Detroit during the summer season. You can visit the world's greatest automobile factories during the long summer evenings; you can visit Detroit's many beautiful parks, or take a boat trip on the Detroit River or Lake Erie; boats leave Detroit wharfs every few minutes. In addition to this, you will find many advantages in our course in summer, such as more pleasant tractor field work, and other outside activities which are less pleasant in winter. Resolve to see Detroit this summer and learn the auto and tractor business.

An M. S. A. S. week end picnic boat trip. This boat rented by M. S. A. S. is free to students and graduates.



Become an Auto Electrician

You can make more money for yourself or for an employer by qualifying as an auto electrician. Employers are glad to pay more money if you can prove that you are worth it. 75% of all car troubles are in the electrical end or arise from it, but there are thousands of auto mechanics who know very little of electricity as applied to automobiles, trucks and tractors. Hundreds of mechanics have come and taken our special electrical course. Some went back to their old jobs but at more money. Others have gone out and doubled their salaries in electric service stations. These stations are always looking for good men.

Learn Auto Electricity Thoroughly

Our electrical course teaches auto electricity from the ground up. You get actual bench work in the laboratory, tearing down and rebuilding motors, generators, magnetos, etc. We have practically every known make of ignition, lighting and starting systems for you to work on. Our course qualifies you fully for electric service work. Leading manufacturers in the auto industry work with us and co-operate in every way possible.

Learn by Factory Endorsed Methods

Packard Motor Car Company says: "We have no hesitancy in recommending M. S. A. S. in every particular."
Hudson Motor Car Company: "We recommend the M. S. A. S. and invite inquiries. Address E. V. Rippingille, Service Mgr."
The International Harvester Co. of America says: "We will gladly co-operate with the M. S. A. S. through our 90 branches in the United States."
Get our Free Catalog and read the many manufacturers' letters.

We Teach Autos, Trucks, Tractors, Tire Repairing, Brazing and Welding, Battery repairing and Machine Shop work, by actual practice on the best equipment.

Actual practice at M. S. A. S.



MICHIGAN STATE AUTO SCHOOL

"The Detroit Auto School" "Endorsed By All Leading Manufacturers"
665 Auto Bldg., 3729 Woodward Avenue, DETROIT, MICHIGAN, U. S. A.

SEND COUPON NOW
MICHIGAN STATE AUTO SCHOOL
665 Auto Bldg., 3729 Woodward Ave., Detroit, Mich.
Gentlemen: Please send me absolutely FREE New 1921 course literature
Catalog: No School News Information as checked below.
 Auto & Tractor Course Machine Repairing Course
 Tire Repairing Brazing and Welding Course
Make each course you are interested in
Name
Street
City
State

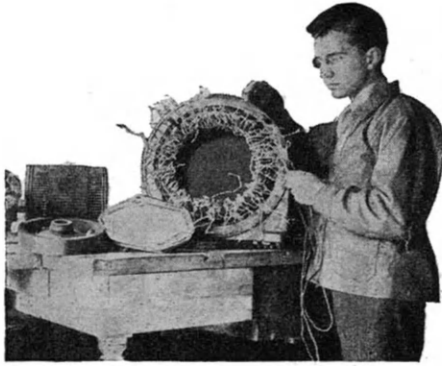

Become An Expert in Armature Work

Trained men who understand Armature building and winding, Motor and Generator Repair and maintenance are in big demand right now. Take up this work and before long you can step into this growing field and insure yourself a permanent, well paying position with big opportunities for advancement.

Learn in 3 Months

In 3 months you can qualify for positions paying highest wages, with bright future opportunities. Come to this well founded and completely equipped school where you learn to actually wind every type and kind of D-C and A-C armatures.

WRITE FOR FREE BOOK

Mail the coupon today for full particulars of our 3 months' course in Armature work. Send the coupon and see how easy it is for you to become an expert on armatures.

SCHOOL OF ENGINEERING OF MILWAUKEE, Dept. SI-5, 373 Broadway, Milwaukee, Wis.

Please send me full information about your three months' course in Armature work. No obligation on my part.

Name.....
 Address.....
 City..... State.....
 Age..... Education.....

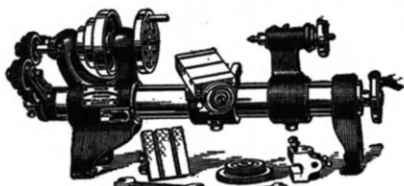

EIGHT MACHINES IN ONE!

The "DRUMMOND" 8-INCH LATHE With Circular Bed

A Lathe that will do Turning, Boring, Drilling, Screw-cutting, Milling and Keyway-cutting. Price most moderate.

The Drummond Lathe is invaluable to Model-Makers, Inventors, Mechanics and Repair Men.

Send for detailed descriptive matter

PRODUCTION EQUIPMENT CO., Inc.

5 Union Square Dept. 6 New York City



If you are earning less than **\$100.00 PER WEEK** and like to draw—you should study

Commercial Art

We teach Composition, Perspective, Technique in pen-and-ink, washes, color, etc., fascinating Design studies, Lettering and Historic Ornament. Advanced courses in Advertising and Costume Illustration.

Leading art managers recommend us and employ our students. Many of our students earn money from the sale of their drawings while studying.

We have Resident classes—both Day and Evening. The same courses by Home Study. Our catalogue on request.

COMMERCIAL ART SCHOOL

Dept. 708, 116 S. Michigan Ave., Chicago, Ill.

Monsters of Long Ago

By Dr. E. BADE
(Continued from page 14)

reason possibly was a change of climate, which acted as a deterrent in the development of the progeny.

THE DAWN OF LIFE

By Will H. Gray

ONE of the most absorbing subjects that can be studied is Geology. Without the life of preceding ages, geology would be almost a closed book. What the very first forms of life were is not known. They may have been some minute microscopic organism, that, as Lord Kelvin suggested, may have come to this earth on a meteorite, or shooting star, from some other life sustaining planet.

The earliest records of life are seaweeds, corals and marine shells, that lived in shallow water. In the deposits in which they are found are the ripple marks left by the waves, and often the marks of rain drops in the mud or sand. Now they are deep underground, oceans and forests have successively covered them, each leaving its remains. Then perhaps some great river cut its way thru the whole mass, leaving exposed the various strata one upon the other.

From the time of the earliest traces of life, there is a series of fossil remains of ever advancing forms. In spite of earthquakes and mighty upheavals, that killed and buried countless millions of little animals, they went steadily on from generation to generation, leaving their shells and bodies ground to powder by the waves to form great beds of rock thousands of feet deep. Now and then a whole insect or fish would become embedded, and in the course of time changed to stone, thus forming a lasting memorial to its kind. By comparing similar fossils in different parts of the world, rock of the same period can be recognised.

In those remote ages, the climate was much warmer than it is to-day, and more evenly distributed. Away up in the frozen north are coal beds formed from great forests of luxuriant vegetation that once flourished there. In those early days of the dawn of life there were no vertebrates. It was not until the middle palaeozoic periods that the earliest vertebrates in the shape of fishes made their appearance. Before the fishes there were crustaceans, which are represented at the present time by shrimps, crabs, and lobsters. On the land there were insects of the scorpion and cockroach type followed in due time by reptiles, something like lizards, that grew and flourished and attained an ascendancy over all other animals. So great were their numbers and so varied their forms, that a whole period of geological time is now known as the Reptilian age.

As the land became more established and less likely to undergo great upheavals, mammals made their appearance, and they in turn increased in size and strength as the reptiles began to grow fewer and smaller.

Last of all came man with the gift of intelligence which enabled him to subdue these great and fierce monsters and drive them from his path. And, altho his bones are seldom found, his weapons and pictures remain to show the kind of life he led. As he advanced these stone weapons and implements improved in workmanship. Bone needles and signs of agriculture go to show that his thoughts were turning to more peaceful pursuits; and with his rapidly advancing civilization, his dominion over the animal world became complete.

Auto Owners WANTED!



To introduce the best automobile tires in the world. Made under our new and exclusive **Internal Hydraulic Expansion Process** that eliminates Blow-Out—Stone-Bruise—Rim Cut and enables us to sell our tires under a

10,000 MILE GUARANTEE

We want an agent in every community to use and introduce these wonderful tires at our astonishingly low prices to all motor car owners.

FREE TIRES for YOUR OWN CAR to a representative in each community. Write for booklet fully describing this new process and explaining our amazing introductory offer to owner agents.

Hydro-United Tire Co.
DEPT. 217 PHILADELPHIA, PA.

AN EASY WAY TO MAKE MONEY

Don't be content to start along on a small salary. Be independent. Go in the tire repairing business. One man says "I made \$90.00 the first day." Others average \$200 to \$500 a month. Very little capital needed. Jobs plentiful. Every motorist a possible customer. No experience needed. We teach you.

SHALER Tire Repair Outfit

Improved Wrapped Tread Method Used by Tire Manufacturers
 Does as good work as the big high priced vulcanizing outfits. A boy can use it. It's the only vulcaniser that has Automatic Heat Control, and can't overheat or overcure a tire. Requires no watching or regulating.



FREE Book
 "How to Open a Tire Repair Shop." It tells how to make big money. Don't delay. Write quick.

C. A. SHALER CO.
2204 Fourth St. Wausau, Wisconsin

\$1500 to \$3000 a Year Charging Batteries

Small Cash Payment Brings You Any HB Battery Charger
 You have almost a year to pay balance on easy monthly terms. There is an HB Charger for every size battery business. Made in sizes to charge 10, 16, 32 or 70 batteries. Choose size you need—then write for information. Start now, building big battery business, strictly cash profits.
HOBART BROTHERS CO.
 Box 57E Troy, Ohio
 Canadian Distributor
 Battery Service & Sales Co.
 Hamilton, Ontario

Big Business—Cash Profits

Cheapest Way to Go
 To work, to school, or for fun and recreation is on a **Ranger Bicycle**. Choice of 44 Styles, colors and sizes. Save \$10 to \$25 on Direct From-the-Factory shipment. 30 Days Free Trial, shipped on approval. We pay the expense both ways if not accepted.
12 Months to Pay in installments. Save time and cartage easily meets the small monthly payments.
 Parts equipment—half usual retail price. Send no money. Write for big, illustrated catalog.
Tires Mead Cycle Company
 Dep. D-107, Chicago



FOR BUSINESS and PLEASURE
 Independent Economical Transportation
 Write for Catalog "E"
Cleveland
 LIGHTWEIGHT MOTORCYCLE
 THE CLEVELAND MOTORCYCLE CO. CLEVELAND, U.S.A.





“I’m as Good a Man as Jim!”

“They made him manager today, at a fine increase in salary. He’s the fourth man in the office to be promoted since January. And all were picked for the same reason—they had studied in spare time with the International Correspondence Schools and learned to do some one thing better than the rest of us.

“I’ve thought it all out, Grace. I’m as good a man as any one of them. All I need is special training—and I’m *going to get it*. If the I. C. S. can raise other men’s salaries it can raise *mine*. If it can bring a better home with more comforts to Jim and his family it can do it for *us*. See this coupon? It means *my* start toward a better job and I’m going to mail it to Scranton tonight!”

Thousands of men now know the joy of happy, prosperous homes because they let the International Correspondence Schools prepare them in spare hours for bigger work and better pay. You will find them in offices, shops, stores, mills, mines, factories, on railroads—everywhere.

Why don’t *you* study some one thing and get ready for a real job, at a salary that will give *your* wife and children the things you would like them to have?

You can *do* it! Pick the position you want in the work you like best and the I. C. S. will prepare you for it right in your own home, in your spare time—you need not lose a day or a dollar from your present occupation.

Yes, you *can* do it! More than two million have done it in the last twenty-nine years. More than 130,000 are doing it right now. Join them without another day’s delay. Mark and mail this coupon!

TEAR OUT HERE

INTERNATIONAL CORRESPONDENCE SCHOOLS
 BOX 6190-B SCRANTON, PA.

Explain, without obligating me, how I can qualify for the position, or in the subject, before which I mark X.

<input type="checkbox"/> ELECTRICAL ENGINEER	<input type="checkbox"/> CHEMICAL ENGINEER
<input type="checkbox"/> Electrician	<input type="checkbox"/> Pharmacy
<input type="checkbox"/> Electric Wiring	<input type="checkbox"/> SALESMANSHIP
<input type="checkbox"/> Electric Lighting	<input type="checkbox"/> ADVERTISING MAN
<input type="checkbox"/> Electric Car Running	<input type="checkbox"/> Show Card and Signs Plateau
<input type="checkbox"/> Heavy Electric Traction	<input type="checkbox"/> RAILROAD POSITIONS
<input type="checkbox"/> Electrical Draftsman	<input type="checkbox"/> ILLUSTRATOR
<input type="checkbox"/> Electric Machine Designer	<input type="checkbox"/> DESIGNER
<input type="checkbox"/> Telegraph Expert	<input type="checkbox"/> BUSINESS MANAGEMENT
<input type="checkbox"/> Practical Telephony	<input type="checkbox"/> Private Secretary
<input type="checkbox"/> MECHANICAL ENGINEER	<input type="checkbox"/> Business Correspondent
<input type="checkbox"/> Mechanical Draftsman	<input type="checkbox"/> BOOKKEEPER
<input type="checkbox"/> Toolmaker	<input type="checkbox"/> Stenographer and Typist
<input type="checkbox"/> Machine Shop Practice	<input type="checkbox"/> Cert. Public Accountant
<input type="checkbox"/> Gas Engineer	<input type="checkbox"/> Commercial Law
<input type="checkbox"/> CIVIL ENGINEER	<input type="checkbox"/> GOOD ENGLISH
<input type="checkbox"/> Surveying and Mapping	<input type="checkbox"/> Common School Subjects
<input type="checkbox"/> MINE FOREMAN OR ENGINEER	<input type="checkbox"/> CIVIL SERVICE
<input type="checkbox"/> ARCHITECT	<input type="checkbox"/> Railway Mail Clerk
<input type="checkbox"/> Architectural Draftsman	<input type="checkbox"/> STATIONARY ENGINEER
<input type="checkbox"/> PLUMBING AND HEATING	<input type="checkbox"/> Textile Overseer or Supt.
<input type="checkbox"/> Sheet Metal Worker	<input type="checkbox"/> AGRICULTURE <input type="checkbox"/> Spanish
<input type="checkbox"/> Ship Draftsman	<input type="checkbox"/> Navigator <input type="checkbox"/> Autos
<input type="checkbox"/> Traffic Management	<input type="checkbox"/> Poultry Raising <input type="checkbox"/> Baking

Name _____

Present Occupation _____ Business Address _____

Street and No. _____

City _____ State _____

Canadians may send this coupon to International Correspondence Schools Canadian, Ltd., Montreal, Canada

ELECTRICITY

In Its Greatest Form
for HEALTH and BEAUTY

ENJOY wonderful, sparkling health! Increase your store of energy, revitalize—re-create—every cell and fibre of your being. You can do this easily, quickly, and inexpensively through the magic of VI-REX Violet Rays.

Violet Rays penetrate to every cell in the body, imparting that stimulating vigor which brings the glow of health—tones up the entire system, putting life into over-taxed and sluggish tissues. As a quick relief from pain, Vi-Rex has no equal.

VI-REX VIOLET RAYS

Try Them Free!

The Vi-Rex Violet Ray Machine is not a vibrator—does not shock or jar the nerve ends. No feeling of soreness or exhaustion after use—only a comforting, agreeable sense of relief.

Write today for our free booklet describing the wonderful Vi-Rex outfit in complete detail and particulars of our liberal 10 days trial offer.

This book explains the manifold uses of Violet Rays in treating almost every known human ailment. It also contains charts and diagrams of the nervous system and organic locations, and fully describes just how the Vi-Rex Violet Ray works its many seeming miracles. Written in a simple style—devoid of all technical language. Get the real facts and practical demonstration FREE. Just mail the coupon below.



VI-REX ELECTRIC COMPANY

326 W. Madison St., Chicago, Ill. Dept. 45

Please send me without cost or obligation your free book describing your wonderful Violet Ray Machine and particulars of your special 10-day Trial Offer.

Name.....
Address.....
City.....State.....

Science In Stage-land

By H. WINFIELD SECOR
(Continued from page 12)

naval battle scene, probably the most pretentious ever produced on the American stage. The scene has been very cleverly worked out by the designers and artists and presents a view as if those witnessing it, were just back of the bridge and right on board the vessel. The effect of the waves and rolling sea is perfect, and the bridge, mast and deck of the cruiser roll lazily in the heavy sea. The pilot's cabin on the bridge is an actual room fitted with wireless and signal light apparatus, and all of the usual fittings found on a warship, everything worked out in highly commendable detail. A strange vessel is sighted by the captain and the dialogue that follows between the captain and his officer, as the ship keeps on rolling thru the heavy sea, grips the audience in its wondrous majesty and dramatic import.

The actions of the strange ship prove somewhat suspicious to Capt. de Corlaix, and he orders successively the usual code signals to establish identification of the ship.

"Stand by your signals!" commands the Captain. "Aye, aye," replies the signalman. "206," calls the Captain. The signalman throws the switches and the Ardois lights flash red—blue—white—green! The Captain and the officers on the bridge scan thru the night with their binoculars, watching for the answer of the strange ship. Back comes the signal RED—the correct one. The officers on the bridge breathe sighs of relief momentarily; the captain, however, knows that the enemy may resort to any sort of trickery and notes that the smoke stacks are not evenly spaced, indicating that one or more of them may be dummies made of canvas or other material, a trick often employed by German raiders to disarm suspicion during the war. After corroboration by one of the officers, he becomes still more suspicious of the suspected ship.

Orders are given to get the suspect's range. "2048," calls the Captain. The signalman complies and the Ardois lights flash out the order of the sea—"Clear my course!" The mysterious stranger of the night comes back with a shell and the great naval battle is on! The men swarm up from below deck on the *Alma* and man their guns, as the bugle calls ring out and the electric buzzer and bell signals sound over the vessel calling the crew to their battle stations. The small and heavy guns roar in action, and finally a French gun makes a hit and a red flare rises over the enemy; but this does not finish him. An enemy shell strikes the pilot house and demolishes part of it, wounding the Captain and many of the men. Finally a torpedo is seen approaching the *Alma*, and the next second it strikes her with a deep thud and a blinding flash. The ship starts to settle slowly and the order goes forth to man the boats, as the curtain falls.

In a few seconds the curtain rises again and the audience is thrilled by one of the greatest scenes of the sea that one can ever behold, altho tragic in the extreme—that of a giant ship taking its last plunge beneath the waves. What appears to be to all intents or purposes the full size stern of the Cruiser *Alma*, as she plunges to her watery grave, to the accompaniment of exploding boilers and escaping steam is seen by the audience.

PRODUCING THE NAVAL BATTLE SCENE

The most startling stage effects produced at this play have been so arranged as to give that sincere touch of realism, conspicuous by its absence in many other productions; for instance, the ship's decks are cleared for action immediately at the end of the first act; so rapid is this change that one

(Continued on page 64)

WINDOW SIGNS

AGENTS 500% PROFIT

Gold and Silver Sign Letters
For store fronts, office windows and glass signs of all kinds. No experience necessary. Anyone can put them on and make money right from the start.

\$75 to \$200 a Week!

You can sell to near-by trade or travel all over the country. There is a big demand for window lettering in every town. Send for free samples and particulars.

Liberal Offer to General Agents
METALLIC LETTER CO.
433Y No. Clark St. CHICAGO, ILL.

SEND NO MONEY

ALL STANDARD MAKES

These tires are all standard makes, formerly guaranteed for 8,000 to 10,000 miles, many practically new. Do not confuse these exceptional high grade tires with sewed or half soled tires. Thousands of users are getting 8,000 to 8,000 miles easy. Every tire we ship is backed by our satisfaction guarantee.

SIZE	TIRES	TUBES	SIZE	TIRES	TUBES	SIZE	TIRES	TUBES
80x3	\$ 6.95	\$ 1.75	88x4	\$ 11.25	\$ 2.50	85x4½	\$ 13.90	\$ 3.15
80x3½	7.95	1.95	84x4	11.90	2.60	85x4	14.50	3.10
82x3½	8.75	2.15	82x4½	12.25	2.70	85½	14.90	3.50
81x4	9.45	2.25	88x4½	12.90	2.85	87½	15.00	3.75
82x4	10.90	2.40	84x4½	13.25	3.00	86x4	15.90	4.00

No money in advance. We ship on approval by Express. See and inspect before you pay. 5 per cent discount if money in full accompanies order. Just write, tell us your size, also whether S.S. or C.L. Send today. While these bargain prices last

KLASS-WORTH CO., 3033 Michigan Ave., Dept. 81 Chicago, Ill.

Ask for free Catalog

UNION

TOOL CHESTS

Ask for free Catalog

Protect your tools from rust, knocks, bangs and theft in absolutely the best tool chests made for Machinists, Tool-makers, Carpenters, Auto Mechanics, Electricians and Household use.

Write for prices and "Satisfaction-or-money-back" guarantee.

Union Tool Chest Co., Inc. 36 Mill St., Rochester, N.Y.

Better Jobs - Better Pay

FOR BURGESS-TRAINED MEN

ELECTRICAL ENGINEERING

PRINCIPLES AND APPLICATIONS



Burgess Training and Burgess Service make a man earn more by making him worth more. If you are a trained man you always have a good position and you practically name your own salary. The untrained man works for whatever he can get whenever he can get a job.

Send for the Burgess Catalog It's a **BOOK FULL OF FACTS**

That Everyone Interested in Practical Electricity Should Know

BURGESS ELECTRICAL SCHOOL

Complete Home Study Course in Practical Electricity
By Exclusive Copyrighted Method

The Burgess Method of Electrical Instruction is different from that in other schools or in books. It is the result of years of practical electrical work combined with long experience in teaching electricity, and writing courses and books. It so fully meets the needs of men in their everyday work that some of the largest electrical concerns in the country have adopted the Burgess Course. After a very thorough investigation they are forming classes for their employees because they find the Burgess Course contains practical information not found elsewhere. The course extends from simple dry cells to hydro-electrical operation; particular effort being placed upon such subjects as storage batteries, wiring calculation, automobile systems, farm lighting systems, motor application, motor installing, motor testing and repairing, armature winding, transmission and power plants, etc., etc.

COMPLETE ELECTRICAL OUTFIT

including Apparatus, Tools and Materials, is supplied with the course without extra charge.

ELECTRICAL DRAFTING

This is a part of the regular work, and drafting implements and materials are furnished students without any additional charge.

ELECTRICAL SLIDE RULE

As a thorough knowledge of the slide rule is so necessary in our business, Mr. Burgess has written 30 lessons on this subject, which are now included as part of the regular course in addition to the lessons in Electricity and Drafting. A Slide Rule and leather case is supplied to each student without charge.

BEGINNERS

Taught By Simplified Methods

The earnest beginner quickly learns at home by the Burgess Simplified Method—gets an electrical job and makes quicker progress than the man who tries to learn only from experience "on the job." No frills or impractical theory. Just "boiled down" information that is of greatest value, and easy to understand clearly.

EXPERIENCED MEN

Advanced By Special Training At Home

Men employed in any branch of the electrical business find that the interesting and easy-to-understand practical information given by The Burgess School is an invaluable help in their everyday work. The Burgess Catalog explains this fully and shows how Burgess Service enables a man to advance rapidly to more important and better paid work. Practical electrical facts, "short-cuts," methods of application, etc., supplied by The Burgess School cannot be obtained in any other school, college, text book, or course. That is why men who have had years of practical experience and school and college training find that Burgess Training gives them just what they need.

A FAIR AND SQUARE STATEMENT

By Yorke Burgess, Superintendent Burgess Electrical School, Chicago, Ill.

"I have been training ambitious men, both young and old, in practical electricity for a number of years by my Home Instruction Method, and would like to send you my catalog, which tells exactly what I do and HOW I DO IT. It also tells why, when and where my students succeed and HOW THEY DO IT. The catalog costs you nothing—it obligates you in no way whatever, but for your own good send for it, as it contains things you should know.

"Thousands of men will make good in the electrical field this year and in the years to come, and I will be helping many to do this under my personal guidance and instruction."

BURGESS ELECTRICAL SCHOOL

745 East 42nd Street Dept. G Chicago, Illinois

Fill out and mail coupon. Check course you are interested in

YORKE BURGESS, SUPT.

Burgess Electrical School, 745 East 42nd Street, Chicago, Illinois.

DEAR SIR:—

Please send me your catalog "G" which explains your Home Instruction Course and the Burgess Service method. For Beginners For Experienced Men

Name.....

Address.....

"Electrical Hand Book"

THE "Burgess Blue Book" contains drawings and diagrams of Electrical Machinery and Connections—Starting Boxes, Elevators, Controllers, Starters for Printing Press Motors, Street Car Controllers, Transformer Connections, Lighting Circuits. The section on Calculations takes up Simple Electrical Mathematics, Wiring Tables, Alternating Current Calculations, etc. It also gives 200 formulas, with problems worked out, showing their application.

Price \$1.00. If you decide not to keep it, your money will be returned

THE BURGESS COMPANY

YORKE BURGESS, President
Consulting Electrical Engineering

750 East 42nd Street, Dept. G Chicago, Illinois

Power Plants, R. R. Signals, Electric Railroads, Motor Troubles and Industrial Problems. Information Furnished on Electrical Subjects. Inventions and Patents Perfected.

ELECTRICAL ENGINEERING TRAINING FOR THE AMBITIOUS MAN IN ONE YEAR

For earnest young men who desire to fit themselves for responsible, good-paying positions, the Bliss Electrical School offers a wonderful opportunity.

In *One Year* this school fits young men to enter the electrical engineering profession with trained minds and a technical education that opens the way to steady advancement.

One Year Now is a small investment on which you will reap big profits. You become the skilled worker for whom industry is constantly seeking, and whom it pays well for knowledge and service.

Every hour is devoted to an intense study of electrical engineering. Bliss graduates are preferred men because they are properly and thoroughly trained. Send for our catalogue.



ELECTRICAL ENGINEERING—IN ONE YEAR

BLISS ELECTRICAL SCHOOL

315 Takoma Park

Washington, D. C.

Learn Tire Repairing

Make at least
\$250 per week

with this Marvelous Super-Vulcanizing Machine, backed by the training you will receive in Our Free Schools.

A wonderful expansible mold that can be perfectly adjusted to fit any size tire.

Master this fascinating occupation; be a scientific Tire Repairman by attending one of our schools.

We give you all necessary information and instruction and help you in every way to get your business started.

Cities and Towns everywhere are

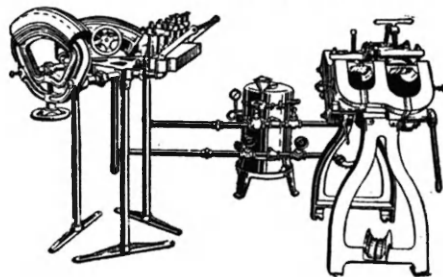

asking for "WESTERN" trained men.

There is no limit to your possibilities. Quit punching a time clock now and resolve to be your own Master.

Write us for our plan to help you establish a business of your own and address of school nearest you.

WESTERN RUBBER MOLD COMPANY

Gen. Office and Main School,

253 N. Crawford Avenue, Chicago, Illinois.

JUNIORPHONE

A THERMO TELEPHONE

COMPLETE TALKING AND SIGNALLING SYSTEM

A PRACTICAL SCIENTIFIC TELEPHONE OPERATING ON A NEW PRINCIPLE.

EASILY ASSEMBLED FOR INSTANT USE CAN NOT BE EQUALLED AS A DISTINCTIVE, INSTRUCTIVE AND INTERESTING NOVELTY.

APPEALS TO ALL UP-TO-THE-MINUTE YOUNGSTERS AS WELL AS TO THE GROWN UPS.

MANUFACTURED BY

AMERICAN THERMOPHONE COMPANY



114-116 BEDFORD ST.

BOSTON, MASS.

Science In Stage-land

(Continued from page 62)

can scarcely follow it with the eye. The signal is given and the guns are lowered into firing position by a ratchet and pawl arrangement. A gunner drops off one of the big guns. At a given signal the *Alma* in the foreground moves thru an arc of about 30 degrees, it being built on a revolving platform the floor of which is made to turn. In the background ships made of segments pass thru a strange metamorphosis and indicate that they are now proceeding in the opposite direction.

In the battle scene this realism attains perfection. Bells in various parts of the stage as shown in our diagram, ring from the various quarters, the sound thus seeming to come from different parts of the vessel.

Colored lights from the *Ardois* are flashed by a man in the cabin. Beautiful wave effects are obtained in the first part of this scene by the regular wave machines (two stereopticons, one on each side of the stage) in which wave slides are constantly kept in motion by means of clockwork mechanism. The cloud effects are shot upon large semi-circular drops giving the true depth effect of the firmament and this, when viewed thru a gauze screen drop covering the proscenium, assists in giving effects of distance and fog.

At the rear a ship is seen all aglow. It is illuminated with myriads of miniature electric lights which are fastened on the sides of the vessel. It is made of metal about 3 feet long and moved on a wheeled wooden platform by a hanging upright. This vessel in addition to the regular lights and signal lights, has two irregular glass windows covered in the back by metal boxes. Cotton immersed in alcohol is placed in these boxes so that when a hit is registered, the operator merely lights the cotton and it appears that the ship is burning. The operator with a flashlight eventually causes the distant flashes of the enemy vessel and an attendant elsewhere in the building, two seconds later, allows the shot gun which he is holding in his hand to belch forth the roar of the enemy guns. Even while the *Alma* is going thru the water, the roar of the breaking waves may be heard above the din of battle as can the thumping of the engine be felt by the entire audience. The "waves" are produced by the wave machine men who utilize a large circular sieve containing some gravel and the breaking of the waves is produced by rolling shot on a large base drum. Then comes the fatal crash, and flashes of powder create the flame, an honest-to-goodness Gattling gun producing the explosion of the torpedo and about 50 feet of steel anchor chain, 4 inches in diameter is dropt upon a steel plate to give the effect of the sides of the vessel being demolisht by the explosion. The thump of the engine which is produced by two tremendous vacuum cleaners down in the cellar at the entrance of the auditorium and has up to this time gently vibrated the seats of the audience, ceases, indicating that the engines have been turned off.

The enemy vessel which has been pushed along on its rollers from the back of the stage bursts into flame. A vivid flame lights up its interior as its supporting structure is bent and it dives beneath the camera waves. The big vessel up to this time has been rocked on its cantilever truss work, stops rocking and seems to gradually settle.

The curtain is dropt momentarily and the next scene shows the stern of the vessel painted on a tremendous canvas, sinking rapidly beneath the surface of the sea, which in this event has been created by moving pictures replacing the former smaller ripples, while steam escapes from alongside the vessel, four shot guns are fired to indicate the explosion of the boilers.

Cut Your Training Time in Half

'LEARN ELECTRICITY —in Only Six Months

HERE, at last, is a new idea in electrical instruction—a plan that thousands of ambitious men have been waiting for. It enables you to complete your electrical training in half the usual time and still get thorough, expert, fundamentally sound instruction. It's a real short cut to electrical success! You can become a

Trained Electrician in 6 Months

Instead of 12—or Learn an

Electrical Trade in 6 Weeks

Learn Wiring in 6 Weeks.

Learn Meter Testing in 6 Weeks.

Learn A-C and D-C Motor, Generator Work in 6 Weeks

Learn A-C and D-C Armature Winding in 6 Weeks.



Administration Building of S. of E.



Students Doing Actual Home Wiring.



Practical Work on A-C and D-C Motors.

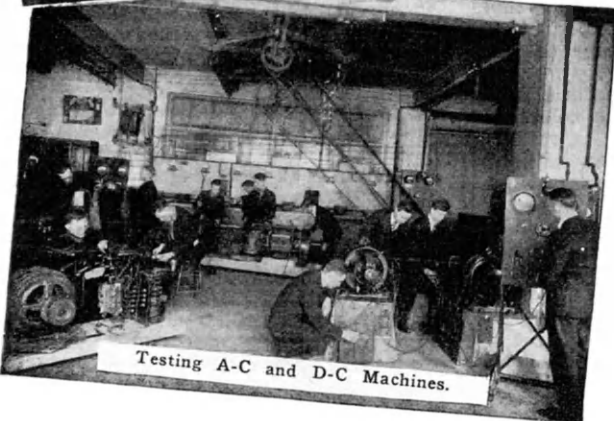

Testing A-C and D-C Machines.

Bear in mind that our training is not shortened to suit the plan. You get the same careful, individual, thorough training that we have been specializing in for fifteen years. The plan is the outgrowth of the desire on the part of many of our students to shorten their training period—to save every minute so they can go out and earn in the shortest possible time. We have simply adjusted our methods to suit supply and demand.

4 Units of 6 Weeks Each

The complete course of 6 months is made up of 4 units of six weeks each. You can learn to be a wireman in 6 weeks, or a meter tester in 6 weeks, or a motor and generator man in 6 weeks, or an armature winder in 6 weeks. You can take all or any of the units you like.

Every Minute 8 Hrs. a Day

This short cut plan gives you 8 hours a day of intensive instruction and training. You spend most of your time in the laboratory. Six weeks of this practical training gives you all you need to make a good living. Many students take up one unit, learn it, then go out and earn enough to complete the full course of electricity. It's AN OPPORTUNITY FOR UNEMPLOYED MEN to prepare for the better job that pays well and employs steady.

A SUCCESS-BUILDING SCHOOL

Back of this big school is a record of over 15 years of successful specialization in electricity. Last year 2300 students from 46 states and 22 foreign countries were in training here. The oldest school of its kind—largest faculty of experts of any similar institution. We help you to

secure board and room facilities at the lowest rates.

INVESTIGATE NOW—Don't wait. Prepare to grasp the opportunities for big pay that are waiting for electrically trained men. A few weeks of study and practice here will fit you for a better job with a bright future.

SCHOOL of ENGINEERING of Milwaukee

"Leading Electrical School of America."

Established 1905

MILWAUKEE, WISCONSIN

MAIL THE COUPON FOR FREE BOOK AND COMPLETE DETAILS

The Class in Practical Electricity, graduating February 25th, 1921, desires to express its feeling of gratitude for the thorough training which the class received. When we look back it is certainly remarkable that we have covered in six months time the four distinct courses which you offer, each in six weeks. They are much more complete and thorough than we ever expected.

Respectfully,
I. V. Beal, Niles, Mich.; Otis Ficks, Leesville, La.; Edwin E. Lorch, Independence, Wis.; A. R. Newton, Langford, So. Dak.; W. H. Walton, Lake Placid, N. Y.; Harry L. Moore, So. Nampa, Ida.; Carl G. Gaustad, Baldwin, Wis.; Carl Lowry, Dassel, Minn.; M. Dale Farrar, Lyndon, Kas.; Nathan G. Wright, Meadowbrook, W. Va.; W. Veersma, Holland, Mich.; Raymond Hand, Marengo, Ill.; Fred Gibson, Scranton, No. Dak.; Raymond Schultz, Prairie du Chien, Wis.; Ralph W. McCullough, Los Angeles, Cal.; Earl C. Granger, Orange, Cal.; John Dinos, Weldon, No. Car.; John C. Ritter, Eveleth, Minn.; B. T. Olson, Baldwin, Wis.

School of Engineering,
 Dept. S. E.-5-373 Broadway, Milwaukee, Wis.
 Gentlemen:—Please send free literature on "Practical Electrical Education" and full details of your short-cut method of instruction in
 Trained Electrician—6 mos.
 Electrical Trade—6 weeks (check those interested in)
 Wiring..... Motor/Generator.....
 Meter Testing..... Armature Winding.....
 Other electrical courses offered by this school:
 Electrical Engineering with B. S. degree—3 years; Electrotechnician, High School and electrical education—1 to 3 years; Electrical and Mechanical Drafting—6 months to 1 year; Automotive Electricity—3 months; Farm Lighting—3 months.
 Name.....
 Address.....
 Town.....
 Age..... Education.....

Shorten the Line Between Training and Earning

A MOTOR FOR YOUR BICYCLE



ATTACH a ROLLAWAY to your bicycle. Forget pedals! Spin along mile after mile—uphill and down—swift as the wind. Ride in comfort—arrive home rested, refreshed and invigorated. The

Rollaway

gives dependable, positive power. No heavy batteries, clumsy clutches, or cumbersome accessories. Just a light, compact motor—weighs less than 25 lbs. Balances perfectly over front wheel. Runs 100 to 150 miles on gallon gas. Wonderful pick-up. Speeds to 26 or throttles down to 6 miles an hour. Powerful in emergencies. It's a wonder from every standpoint. Do not buy a motor attachment until you have investigated the remarkable ROLLAWAY. Choice of two models. Friction drive, \$29.50. Belt Drive, \$38.50. The two greatest values ever offered in bicycle attachments. Write for FREE circulars.

THE ROLLAWAY CO.
515 Shepard St., Toledo, O.



Rollaway Motor Friction Drive

Rollaway Bicycle Motor Belt Drive Model

BE OUR RIDER SALESMAN Buy ROLLAWAY and demonstrate. Cyclists amazed. ROLLAWAY sells on sight. Take orders right and left. Big commissions paid. Write now for exclusive territory. Send AT ONCE for splendid proposition. Don't wait!

Rollaway

TRADE MARK

Optical Lenses Colored by Electricity

BY HARRY ROSENTHAL
(Continued from Page 29)

of 1920, an elapsed time of over six years, and the specimen showed a net change of less than 2 per cent. A brief description of the process is given below:

The regular supply of electric current is past thru a transformer where the potential is raised to a very high voltage. This voltage, carefully insulated, is brought inside of a cabinet thru a controlling device and enters a special evacuated glass chamber, called an *Electron Generator*. This Generator is maintained at a very high vacuum and it contains two metallic electrodes, one of which is constantly cooled by flowing water connected directly to the water supply and the overflow of which is carried directly to the drain. It also contains a filament which is heated to a glow.

When a body is heated to a glowing point it sends off gaseous particles and electrons. These electrons being in a vacuum, are bombarded back and forth between the metallic electrode by the high tension of the circuit, and the ones that strike the electrode, which is cooled by the water, are sent out of the chamber. These are the ones which affect the glass. Directly under the electron chamber are rotating wheels which carry the lenses to be treated. The distance of a lens from the electron chamber is carefully regulated by micrometer adjustment. Below the rotating wheels is an automatic timing device which regulates the length of treatment for the lens. The operator, knowing the exact distance of the electron chamber from the lens, as measured on a scale on top of the apparatus, and knowing also the amount of current which is sent into the apparatus, as measured by the two meters, one on the switchboard and one on the apparatus, can always duplicate results by setting the automatic timing device. This means that lenses can always be matched for their color. This is impossible to do today with chemically colored glass. Some of the chief advantages of treating lenses by this process are:

The ability to treat white optical lenses after they are ground and polished and ready to be mounted. By doing this an evenness of tint is obtained even in lenses of extreme focus. By this process it is possible to obtain the same tint in lenses which are very thin in the center and thick on the edge or vice versa. This is impossible to do when ordinary colored glass is used.

No color distortion, therefore even transmission of all the visible colors of the spectrum.

The reduction of the brilliancy of light. The absence of noticeable color, when the lenses are being worn.

Any person wearing white lenses will be benefited by having these lenses treated because the effect of the treatment is to tone down the brilliancy of light without in any way disturbing the relative color values to the wearer.

By this process it is possible to color bi-focal lenses the same color all over, or else to leave a portion white.

The present process requires only a few minutes to treat a pair of lenses; this enables the optician and oculist to get practical immediate service.—Photos and data courtesy Rosenthal Electric Lab., Camden, N. J.

You Can KNOW

all about AUTOS, TRACTORS, AEROPLANES, STARTING and LIGHTING SYSTEMS, STORAGE BATTERIES, VULCANIZING, etc.

Valuable Book FREE

"How to Succeed in the Automobile, Tractor and Aeroplane Business," gives much new and very useful information; also tells all about the many splendid advantages and practical training you can get at this college in a few weeks. Tear this out and write for a copy, FREE, today.

GREER COLLEGE
OF AUTOMOTIVE ENGINEERING
Dept. 123 1519 S. Wabash Ave.
CHICAGO

Cut Your Tire Cost

Pocket 50% and more by buying 5000 mile **CONQUEROR Double-Tread** tires, made only from the best selected materials, in our own factory by thoroughly experienced workmen, insure maximum mileage at 1/2 to 2/3 usual cost and are placed on the market with an

IRON GLAD GUARANTY

Put in a supply of your sizes now at these amazing low prices, while they last:

Size	Tire	Tube
30x3	\$5.25	\$1.75
30x3 1/2	6.25	1.90
32x2 1/2	6.75	2.00
31x4	7.50	2.05
32x4	8.00	2.15
33x4	8.25	2.25
34x4	8.50	2.35
34x4 1/2	9.75	3.51
34x4 3/4	10.00	2.65
34x4 1/2	10.50	2.65
35x4 1/2	11.00	2.75
35x5	11.75	2.85
37x5	12.75	2.95



Tubes are guaranteed fresh stock. Send only \$2.00 with each tire ordered. Balance C.O.D. subject to examination. For full cash without deduction 5%. State whether extra wide or clincher plain or no skin desired. Order NOW—TODAY—get greatest value for your money.

CONQUEROR TIRE & RUBBER CO.
3031 S. Michigan Blvd. Dept. 140 CHICAGO

THE ALSOP-ALL-SPARK

BEST BY GOVERNMENT TESTS

This simple little device does away with Spark Plug and Ignition Troubles, pays its owner big dividends. It saves spark plug and starts. Eliminates Carbon—gives your car greater power—will fire old or cracked plugs no matter how full of oil or grease. Insures a hot spark. Prevents misfires. Makes it easy. Send your order today and put it on to your engine troubles. Cost complete, with Money-Back Guarantee, \$7.50

ALL-SPARK IGNITION CO.
Mail Order Dept.
13 Water St., N. Y. City

CONVERT YOUR BICYCLE INTO A MOTOR CYCLE

by using a STEFFEY ATTACHMENT
Simple-Reliable-Economical
Fits any ordinary wheel, diamond, double-bar or truss frame. Easy to attach. Send stamp for circulars.

STEFFEY MFG. CO.
Dept. E, 5025 Brown Street, Philadelphia, Pa.

You Can Save \$50.00

By recovering your old auto top from yourself. We make these recoveries to fit all makes and models of cars. Any person that can drive a car can put it on. Panels Post Paid We furnish instructions, Roof and quarters and with rear curtain, fasteners, walts and tacks. All complete. Give us the name, year and model number of your car and we will send you our catalogue with samples and quote you exact price.

LIBERTY TOP & TIRE CO., Dept. E4, Cincinnati, O.

Tire Agent

We want one exclusive representative in each locality to use and sell the new Mellinger Extra-Ply, hand made tires. Guarantee Bond for 5000 Miles. (No seconds). Shipped prepaid on approval. Sample sections furnished. Don't buy until you see our special agents. Write for details.

MELLINGER TIRE & RUBBER CO.
901 Oak St., Kansas City, Mo.

BE A REAL MAN!

LOOK LIKE ONE AND FEEL LIKE ONE

Broaden your shoulders, deepen your chest, enlarge your arms, and get a development that will attract attention. Fill yourself full of energy and be powerful.



My New Book "Muscular Development" Will Explain How

This book is illustrated with 25 full page photographs of myself and of some of the world's finest developed athletes I have trained. It will interest and benefit you greatly.

Send 10c (stamps or coin) for a copy NOW, today, while it is on your mind.

EARL LIEDERMAN, Dept. 205 305 Broadway NEW YORK CITY

1/4 MOTORS

H. P., 110 volts, A. C., 60 cycle, single phase. 1750 R. P. M.

LARGE QUANTITIES NEW WASHING MACHINE MOTORS

These are of standard manufacture and carry the full factory guarantee. Shipped in original boxes. Complete as set. Suitable for special Coffee Grinders, Cream Separators, Bottle Washers, Air Compressors, Small Lathe, etc.

\$22.75 Each

MANUFACTURER'S DISTRIBUTOR
WAS. H. JOHNSTON - Box 12 W. E. Pittsburgh, Pa.

Home Electric

By G. L. HOADLEY, M. E.

(Continued from page 40)

heavy filament used in 100 watt gas-filled lamps and larger sizes has less surface exposed to the circulating gas compared to its volume than the small filament used in lamps of less capacity, hence the heat losses in gas-filled lamps of much less than 50 watts are considerable.

The Rating of Lamps: Formerly lamps were rated in candle power. The old standard size carbon lamp gave off light equivalent to 16 candles and was so rated; it used 50 watts. The modern Mazda B lamp, vacuum type, is rated at 25 watts and gives approximately 16 candles. The same light then, can be obtained for one-half the cost. Lamps are now standardized at 10-15-25-60-75-100 watts. Nothing is said about candle power.

Cost of Electric Light: Suppose a dwelling uses the following lights and it is desired to compute the cost:

Kitchen 2 50-watt lamps—100 watts
Dining-Room 4 50-watt lamps—200 watts
Living-Room 4 50-watt lamps—200 watts
(With floor lamp)

Total500 watts

The maximum connected load, then, is 500 watts or 0.500 kilowatt. For the first 30 hours use of this maximum load or $(30 \times 5) = 15$ kilowatt-hours you pay at the rate of 10 cents or $(15 \times 10c) = \$1.50$. For the second 30 hours use of the maximum load you pay at the rate of 6 cents or $(15 \times 6c) = \$0.90$. For anything more than (15×15) or 30 kilowatt hours you pay at the rate of \$0.03 per kilowatt hour. Your meter bill will appear then somewhat as follows:

Meter	Total	First	Second	Excess
Read-	Con-	30 hrs.	30 hrs.	over 60
ings	sump-	use of	use of	hrs. use
	tion	Max.	Max.	of Max.
		KW hrs.	KW hrs.	KW hrs.

May 28				
0850	32	15	15	2
April 28				
0818				

Cost15 x 10c 15 x 6c 2 x 3c
Total Amount of Bill.....\$2.46

"WHISPERING MOUTHPIECE" FOR TELEPHONE.

These attachments are supposed to reduce the necessity of loud talking in the transmitting telephone or microphone, and to improve the vocalization

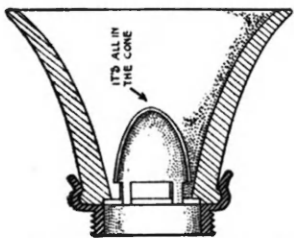

New "Whispering" Mouthpiece.

of the receiver. A paraboloid reflector or deflector is placed at the base of the mouthpiece. It is held there by the mouthpiece proper which screws and clamps it in position. The parabolic reflector, is supposed, according to the inventor to concentrate the sound waves on the transmitter diaphragm so as to do away with the necessity of shouting. An incidental feature is that the mouthpiece is made of glass, which is certainly conducive to the sanitary features of the telephone. A similar attachment is provided for the receiver.

Learn Mechanical Drawing

Men Needed

Salaries:
\$35 to \$100
per Week



I personally stand back of the Columbia School of Drafting—founded, directed and owned by myself—and guarantee the training given by it to be absolutely as represented. The work of each one of our students has my personal supervision. We seek "Quality" students rather than "quantity," as our proposition is of the highest character in every respect.

Roy C. Clafin
President

Are you earning less than \$35 a week? Can you reasonably expect your present position to pay you \$35 to \$100 a week in the near future? If not, this offer will interest you. We offer to qualify you for a profession which, at the very start, pays higher salaries than the average man receives. We offer you the best personal service obtainable. We offer you personal instruction in mechanical drawing and teach you expert Draftsmanship in your spare time, at your home, by mail, in the same practical way that you would learn it in any big Drafting department. We offer to qualify you for one of the many high-salaried positions in the Drafting field, and to keep you in touch with openings for Draftsman in big machine shops, industrial plants, manufacturing concerns and United States Government Departments. We guarantee to start you on real Drafting work at once qualifying you as a thoroughly trained professional Draftsman, capable of succeeding from the very start. One of the many outstanding features of our training is that it qualifies you in an unusually short time.

Become a Chief Draftsman

You cannot make a mistake by taking up mechanical drawing. The field is not crowded, nor can it be. No single profession today offers better opportunities. The great need for trained Draftsmen continues to increase. Each step forward in mechanical development creates a need for more trained Draftsmen. Promotion in this field is sure and certain. Men who start as Draftsmen are often advanced to Chief Draftsmen, Chief Engineer, Production Manager or other high-salaried positions. There is a constant demand for our graduates. We cannot supply them rapidly enough. Many of them are accepted even before they complete their training. This unusual demand for "Columbia" Trained Men is explained by the fact that our students enter upon actual drawing work the day they receive their first lesson. They spend no time with unnecessary preparation or useless theory.

The Largest Institution Specializing in the Training of Draftsmen. Teaches You Mechanical Drawing at Your Home.

This is the mechanical age in world history. The day of big opportunities for technically trained men is here. Especially is this true in the case of Draftsmen, on whom the mechanical industries of America and the entire world depend. On no one profession does the continued development of machinery so nearly center. With the training which we can give you at your home, your services will always be in demand, at a premium, in this permanent, highly paid field.

Drawing Instruments Furnished Send in the Coupon Today

We supply our students with complete drawing equipment. A professional outfit is furnished, together with a highest grade set of Drafting instruments for your permanent use.

It Brings to You full particulars of our proposition. Your future depends upon what you do now. We cannot begin to tell you here, in so few words, of the advantages afforded you by this unusually practical course in up-to-date mechanical drawing. If you are in earnest and desire to learn a big-paying profession, we urge you to act now by returning the following coupon. We will immediately send you our book of information, "Your Future in Drafting," which tells of our new method of teaching mechanical drawing and outlines our offer to you fully.

No Previous Training Necessary

As our students are put into actual practice at the beginning, they grasp the essentials of drawing quickly. The lessons supplied are thorough, clear and easily understood even by those who have had no previous technical training of any kind. No previous experience or special education is necessary.

SEND THIS COUPON TODAY

COLUMBIA SCHOOL of DRAFTING

Dept. 1437, 14th and T Sts., WASHINGTON, D. C.

Without obligation to me, please send me your illustrated book on Drafting, telling how I can secure your complete home study course and your help in securing a position as Draftsman.

Name.....Age.....

Address

City.....State.....

COLUMBIA SCHOOL of DRAFTING

Roy C. Clafin, President

Dept. 1437, 14th and T Streets
WASHINGTON, D. C.

Mechanical Engineering

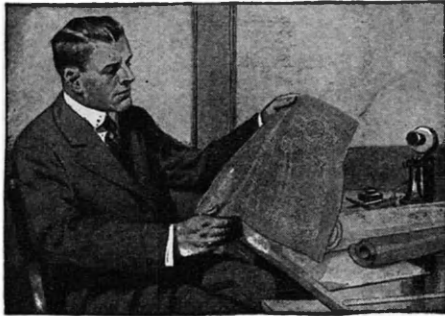

Learn at Home!

Employers everywhere are looking for men with mechanical ability. Splendid salaries and rapid advancement are offered.

There is an easy, delightful way in which you can learn right at home in spare time. For 29 years the International Correspondence Schools have been giving men and women just the training they need for success in mechanical engineering and more than 200 other subjects. Hundreds of thousands have stepped into good positions through I. C. S. help, but never were opportunities so great as now.

Let the I. C. S. help you. Choose the work you like best in the coupon below, then mark and mail it today. This doesn't obligate you in the least and it will bring you information that will start you on a successful career. This is your chance. Don't let it slip by. Mark and mail this coupon now.

INTERNATIONAL CORRESPONDENCE SCHOOLS

BOX 6191-B SCRANTON, PA.
 Explain, without obligating me, how I can qualify for the position, or in the subject, before which I mark X.

- | | |
|---|---|
| <input type="checkbox"/> ELECTRICAL ENGINEER | <input type="checkbox"/> SALESMANSHIP ADVERTISING |
| <input type="checkbox"/> Electric Lighting and Wye. | <input type="checkbox"/> Window Trimmer |
| <input type="checkbox"/> Electric Wiring | <input type="checkbox"/> Show Card and Sign Ptg. |
| <input type="checkbox"/> Telegraph Engineer | <input type="checkbox"/> Railroad Positions |
| <input type="checkbox"/> Telephone Work | <input type="checkbox"/> ILLUSTRATING |
| <input type="checkbox"/> MECHANICAL ENGINEER | <input type="checkbox"/> Cartooning |
| <input type="checkbox"/> Mechanical Draftsman | <input type="checkbox"/> BUSINESS MANAGEMENT |
| <input type="checkbox"/> Machine Shop Practice | <input type="checkbox"/> Private Secretary |
| <input type="checkbox"/> Toolmaker | <input type="checkbox"/> Business Correspondent |
| <input type="checkbox"/> Gas Engine Operating | <input type="checkbox"/> BOOKKEEPER |
| <input type="checkbox"/> CIVIL ENGINEER | <input type="checkbox"/> Stenographer and Typist |
| <input type="checkbox"/> Surveying and Mapping | <input type="checkbox"/> Cert. Pub. Accountant |
| <input type="checkbox"/> MINE FOREMAN OR ENG'N | <input type="checkbox"/> TRAFFIC MANAGER |
| <input type="checkbox"/> STATIONARY ENGINEER | <input type="checkbox"/> Railway Accountant |
| <input type="checkbox"/> Marine Engineer | <input type="checkbox"/> Commercial Law |
| <input type="checkbox"/> Ship Draftsman | <input type="checkbox"/> GOOD ENGLISH |
| <input type="checkbox"/> ARCHITECT | <input type="checkbox"/> Common School Subjects |
| <input type="checkbox"/> Contractor and Builder | <input type="checkbox"/> CIVIL SERVICE |
| <input type="checkbox"/> Architectural Draftsman | <input type="checkbox"/> Railway Mail Clerk |
| <input type="checkbox"/> Concrete Builder | <input type="checkbox"/> AUTOMOBILES |
| <input type="checkbox"/> Structural Engineer | <input type="checkbox"/> Mathematics |
| <input type="checkbox"/> PLOMBING AND HEATING | <input type="checkbox"/> Navigation <input type="checkbox"/> Spanish |
| <input type="checkbox"/> Sheet Metal Worker | <input type="checkbox"/> AGRICULTURE <input type="checkbox"/> Teacher |
| <input type="checkbox"/> Textile Overseer or Supt. | <input type="checkbox"/> Poultry Raising <input type="checkbox"/> Banking |
| <input type="checkbox"/> CHEMIST | |
| <input type="checkbox"/> Pharmacy | |

Name _____
 Present Occupation _____ Business Address _____ 1-1-21
 Street and No. _____

City _____ State _____
 Canadians may send this coupon to International Correspondence Schools Canadian, Ltd., Montreal, Canada

COPPER Air Tight KETTLES—Send No Money

Simply send a postcard—at once—and we'll send this 100% pure, heavy, cold rolled, solid copper kettle right to your door—perfect and complete in every detail. But you must act quickly. At these special low prices this wonderful kettle will be snapped up at once. Don't send a penny—simply drop a postcard. Note these amazing bargain prices:

2 gal. size \$4.00	10 gal. size \$ 9.87
4 " " 5.00	15 " " 15.00
6 " " 6.42	20 " " 20.00
8 " " 8.34	25 " " 25.00

50 gal. size \$50.00



TO DEALERS

You can't duplicate this value anywhere. Special spunned covers—extra heavy handles—positively airtight kettles—they're going fast. Don't delay—send your order today. Here's our special limited offer: We'll ship kettle by express direct to your address. On receipt you simply pay express agent for kettle and expressage. Order at once—a wonderful kettle at this low price. Packed in strong plain wooden boxes. Mail postcard now. The PEOPLES FAIR STORES
 2640 W. Madison St., Dept. 700, CHICAGO, Ill.

The Human Aura

By H. GERNSBACK

(Continued from page 27)

gine and a furnace, giving out a certain amount of heat. We know that heat changes the ambient atmosphere, as does everyone who has looked across a hot stove plate, when ordinary air, invisible before, becomes plainly visible, by a sort of refraction effect, popularly called "boiling." Objects seen behind the plate, suddenly seem to become distorted.

That heat has something to do with the human aura seems to be borne out by the fact that no aura has ever been seen on a corpse after a subject has died. The aura in all cases vanished within a few hours after the death of the subject.

Dr. Kilner had tried at times to photograph the aura, but had never succeeded, and for this reason it seems that the phenomenon hardly can have much to do with ultra-violet rays as a whole. If it had, the photographic plate should be able to register the effect, as most photographic plates are sensitive to ultra-violet rays. When then is the real reason?

The writer advances a theory that may be rather startling at first, but it seems to fit every requirement in the case. He simply thinks that the aura is nothing more or less than the chemical emanation exuding from every animal body. In other words, the writer believes that what Dr. Kilner has done is merely making visible the odors of the human body.

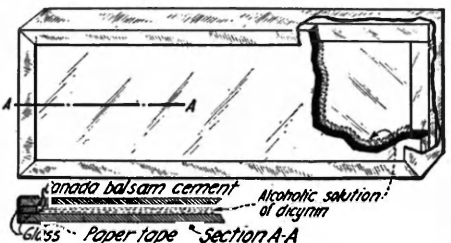

Diagram Showing How the Dicyanin Screens Used for Viewing the Human Aura Are Constructed. The Glass "Box" So Formed Is Filled With An Alcoholic Solution of Dicyanin. Sometimes Several of These Screens, One in Front of Another, Have to Be Employed to Attain Certain Results.

Take a piece of scented soap, a perfume, or an onion, if you care. You will have no difficulty in smelling the odor of these substances from a distance. These scents that are thrown off by the various substances are very material and are corpuscular in composition. They are very fine particles floating in the air and these particles naturally are densest near the substance. Suppose we could make the emanation of an onion visible to the human eye. What would we observe? We would see the onion enveloped in a sort of mist, densest near the vegetable, growing less dense as the distance increases. The same should therefore be the case with the human body, which as we know gives off a certain emanation from the cells and glands of the skin. Perhaps Dr. Kilner has made it possible with the use of dicyanin to make visible what we know as a fact exists, viz., an odorless envelop surrounding the human body. This theory fits all the observed phenomenon which Dr. Kilner made, particularly the one of the electrification. If the human aura is composed of corpuscles, the ionization effect of the Wimshurst machine would certainly tend to disperse the aura for the time being, and as soon as the current is turned off, the aura would return again.

The human aura is a fascinating subject and has now been brought into the realms of physical research. Its chief use probably will be for physicians in diagnosing certain diseases as Dr. Kilner already has done.

Mr. Car-Owner

Save Money! Buy Dependable Double Tread Tires. Guaranteed for 6,000 Miles Service

Dependable Tires are constructed of the highest grade material and hardly ever blow out. Order today at these low prices.

Size	Tires	Tubes
30x3	\$5.50	\$1.60
30x3 1/2	6.50	1.75
31x3 1/2	6.75	1.85
32x3 1/2	7.00	2.00
31x4	8.00	2.25
32x4	8.25	2.40
33x4	8.50	2.50
34x4	8.75	2.60
34x4 1/2	10.00	3.00
35x4 1/2	11.00	3.15
36x4 1/2	11.50	3.40
37x5	12.75	3.75

You'll reorder like thousands of others—because these guaranteed tires "make good" every where—every time.

Dependable tires are only guaranteed for 6,000 miles, but it is not unusual for them to give 8,000 to 10,000 miles service. Send \$2 deposit for each tire ordered, balance C. O. D. subject to examination. State whether S. S. or Clincher, plain or non-skid. Send full amount and save 5% discount. Order NOW.
DEPENDABLE TIRE & RUBBER CO.
 3448 Ogden Ave. Dept. 123 Chicago

Put Your Initials On Your Car

AGENTS SALESMEN GOLD TRANSFER MONOGRAM INITIAL LETTERS

Full Time or Sideline NO LICENSE NO EXPERIENCE NO

Every automobile owner wants his initials on his car. You apply them while he waits, charging 25c per letter, three letters on each side of his car; six initial letters in all cost him \$1.50; you make \$1.38 profit. He could not get finer work if he paid \$5; then again no sign painter could give him as nice a job as you could do without experience in 15 minutes; or sell to individual auto owners their initials; or you can sell to garages and supply stores complete display outfits like the one illustrated at his profit.

A clean, dignified business for ambitious men—put in your whole time or spare time. Write us today for free sample, General Agency, and full details showing how you can make \$10 to \$25 a day from the start.

TRANSFER MONOGRAM CO.
 Bowers Bldg., Desk E, 191 Market St., Newark, N.J.

TIRE PRICES CUT

A High Standard Reconstructed Tire at 65% Saving. Guaranteed 6,000 Miles.

Size	Tires	Tubes
30x3	\$5.25	\$1.50
30x3 1/2	6.25	1.75
32x3 1/2	6.75	1.85
31x4	7.85	2.00
32x4	8.10	2.25
33x4	8.25	2.35
34x4	8.50	2.45
34x4 1/2	10.00	2.50
35x4 1/2	10.50	2.75
36x4 1/2	11.00	2.85
35x5	11.75	3.00
37x5	12.00	3.25

Reliner Free with Every Tire. State whether you want straight side or clincher, plain or non-skid. Send \$2.00 deposit for each tire; \$1.00 deposit on tubes; balance C. O. D. subject to examination, or 5 per cent. discount if full amount is sent with order.

UNITED ECONOMY TIRE CO.
 265 W. 48th St., New York, N. Y. Dept. D.

Oh Boy! Build This Car

This nifty little car driven by gasoline motor can be built by any boy. New Bizi plans, bigger, better than ever. Now ready. Send 30c for building plans and price list of parts showing how to build a car.

SYMPHER MFG. CO. 156 Sypher Bldg., Toledo, Ohio

ENINGER WILL SAVE

440 BIG MONEY SAVINGS FOR YOU

Used and rebuilt motorcycles, single and twin. \$25 to \$100. Used bicycles, \$5.00; tan dems, \$10. All machines guaranteed in good working order. New bicycles and motorcycles at Factory prices. You save dealers' profits. Motorcycles and automobiles tires too. \$3.00. Complete line of parts and supplies.

Send for catalog
Daninger Cycle Co., Rochester, N.Y.

YOU 25 TO 50 DOLLARS

STAMPS

50 all diff. British Guiana, Cuba, China, India, Jamaica, Japan, Portugal, Venezuela, etc., only 10c; 100 all diff., 15c; 1000 all diff. fine collection in 1921, \$5.00; 100 diff. U. S. 800+ 1000 hinges, 10c. Agents wanted, 50% commission. List free. I BUY STAMPS.
L. B. DOVER LONGMONT, COLO.

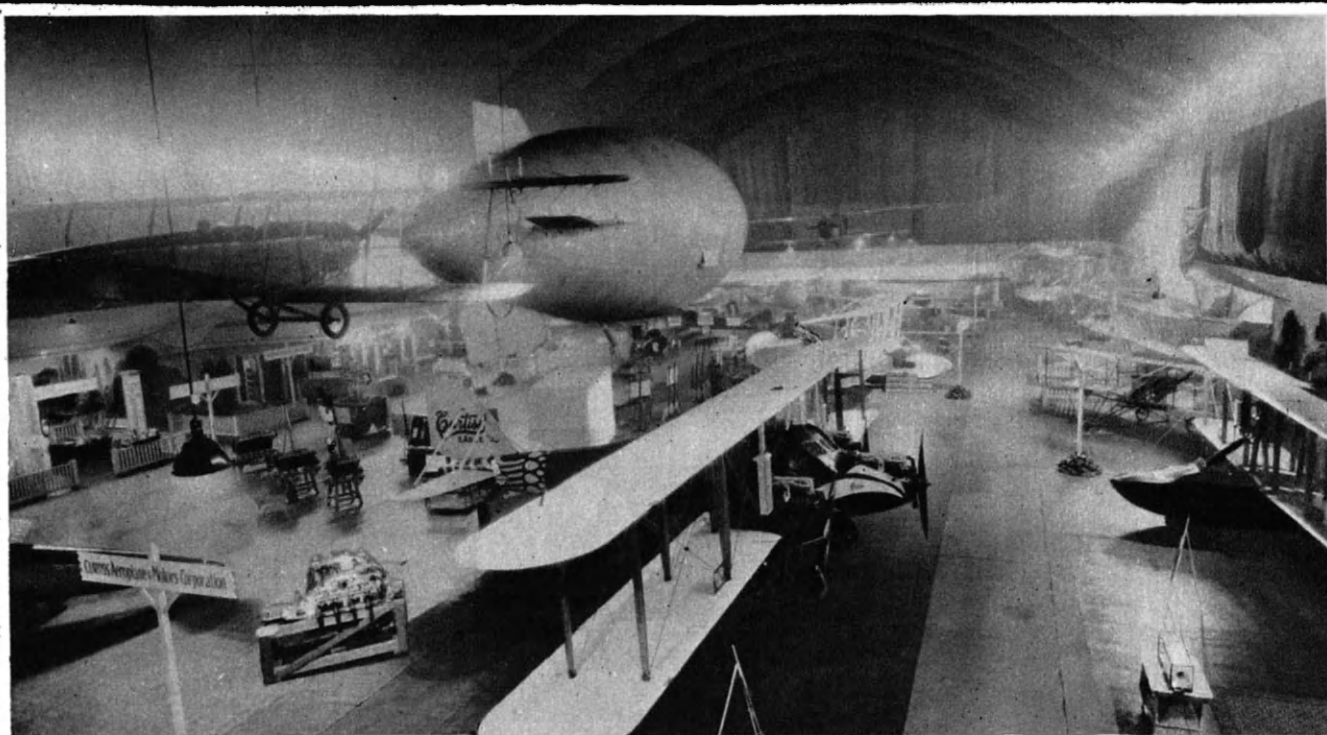

Aviation Brings Quick Success Fascinating—Daring—Big Paying

To young men of daring no other field of work offers such a fascination, such high pay, nor such opportunities for quick success as the field of Aviation. As yet, aviation is practically in its infancy. NOW is the time to get in.

Amazing Opportunities In Airplane Industries

In the automobile industry and in the moving picture business hundreds of men got rich by getting in at the start. They made their success before others woke up. Today, these lines offer no greater opportunities than a hundred and one others. **BUT AVIATION IS NEW.** Get in while the opportunity and pay are big. All over the country there is a clamor for trained men. It is not a question of pay but of getting capable men.

A Sore and Easy Method of Becoming an Aviation Expert—\$50 to \$150 per Week

The study of aviation is almost as fascinating as the actual work. Every lesson is full of interest. That is why it is easy to learn aviation. You do not have to make yourself study—it is like reading an interesting book that tells you things you have always wanted to know.

PREPARE FOR ONE OF THESE POSITIONS

- Aeronautical Instructor \$60 to \$180 per week
- Aeronautical Engineer \$100 to \$300 per week
- Aeronautical Contractor Enormous profits
- Aeroplane repairman \$60 to \$75 per week
- Aeroplane Mechanician \$40 to \$60 per week
- Aeroplane Inspector \$80 to \$75 per week
- Aeroplane Salesman \$8000 per year and up
- Aeroplane Assembler \$40 to \$65 per week
- Aeroplane Builder \$75 to \$200 per week

Only one hour each evening will give you the basic training in a surprisingly short time

One student, S. F. McNaughton, Chicago, says: "Your lessons are like a romance, and what is more, after one reading, the student gets a thorough understanding. One never tires of reading them." James Powers, Pa., another student says: "I am indeed surprised that such a valuable course can be had from such practical men for so little cost."

Personal Instruction By Experienced Men

Men who have had actual experience give you personal attention. They select the lessons, lectures, blueprints and bulletins. They tell you things that are essential in everyday practice. Each lesson is easy to read and understand.

Get Big FREE Book Now

Send coupon below for New Book, just out, "Opportunities in the Airplane Industry." It is interesting and instructive. It will show you many things you never knew before about aviation. Due to shortage of paper we could get only a limited supply of these books—send the coupon before they are all gone.

**American School
of Aviation**
8661 Michigan Ave.
Dept. 7445 Chicago, Ill.

What Students Say:

"After completing your Course I have been with the St. Louis Air Mail Corporation helping build planes. I have climbed in both pay and position, being foreman of the assembling."—*T. A. Kent, Ill.*

"I have received my License and am more than pleased. I can hear the thank you message for the way you have personally taken up my application."—*Edward Reed, N.Y.*

"I have never before received so much valuable information from books or data, as I have from your correspondence. When I used to think of trying to design a plane of any kind and thought of all the mathematical necessities, I nearly came to as a halt. I had with your Course to do as many as working plain arithmetic and that is saying a lot."—*J. M. Stewart, N.Y.*

From an Aviation Expert:

"Any one who takes up at the moment completing your Staff immediately realizes that to receive the benefit of their research work will be invaluable, for they are men nationally known for their pioneer work in aeronautics. The student who wishes to learn the inner secrets of airplane design will find that your Lessons, Bulletins, Blue Prints, Lectures, etc., contain information not found in books or magazines. They are trade secrets and are jealously guarded by airplane manufacturers."—*J. Colin Brown, Los Angeles, Cal.*

AMERICAN SCHOOL OF AVIATION
8661 Michigan Ave., Dept. 7445 Chicago, Ill.

Without any obligation, send me your Free Book, "Opportunities in the Airplane Industry," also information about your Course in Fractional Aeronautics.

Name _____

Street _____

City _____ State _____

CIRCULATION
LARGER THAN
ALL OTHER
RADIO JOURNALS
COMBINED



FOR SALE
AT ALL NEWS
STANDS

ARTISTIC
TWO COLOR
COVER

"THE 100% WIRELESS MAGAZINE"

**VERY
SPECIAL**

FOR A SHORT TIME
A full year's subscription to both



AND

*Science and
Invention*

Regular Price \$5.00

BOTH FOR

\$3.95 USE COUPON
Save \$1.05

What "Radio News" Is:

RADIO NEWS now in its second year holds the field undisputedly as the greatest radio magazine in print today. In point of circulation, number of articles, illustrations, RADIO NEWS leads all other wireless magazines. The April issue has 88 pages; there are seventy-nine separate purely radio articles and 140 illustrations. *Over forty-six thousand copies were printed and circulated.*

20c.
The Copy \$2.00
A Year
Canada and Foreign \$2.50 A Year

SEND 10c. FOR SAMPLE COPY TODAY

Each issue of RADIO NEWS contains 88 pages (or more) and an artistic cover in two colors. The illustrations average 140 every month and there are from 60 to 80 up-to-date articles, some by our greatest radio scientists, in every issue.

REGULAR DEPARTMENTS:

- Latest Radio Achievements.
- General Radio News:
- Radio Telephony.
- "Radio Constructor."
- Radio Stories.
- "Radio Digest."
- "Club Gossip."
- "With the Amateurs."
- "Junior Section."
- "Junior Constructor."
- "I-Want-to-Know."
- "Correspondence from Readers."
- "Dictionary of Radio Terms."

88 PAGES

140 ILLUSTRATIONS

SPECIAL OFFER

Gentlemen: Please enter my subscription for both "RADIO NEWS" and "SCIENCE AND INVENTION" for the term of one year for which I enclose herewith \$3.95. (Add \$1 for postage if for foreign country.) I have written my name and address in margin below.

EXPERIMENTER PUB. CO., 231 Fulton St., N. Y. C.

Quick Success in Electricity!

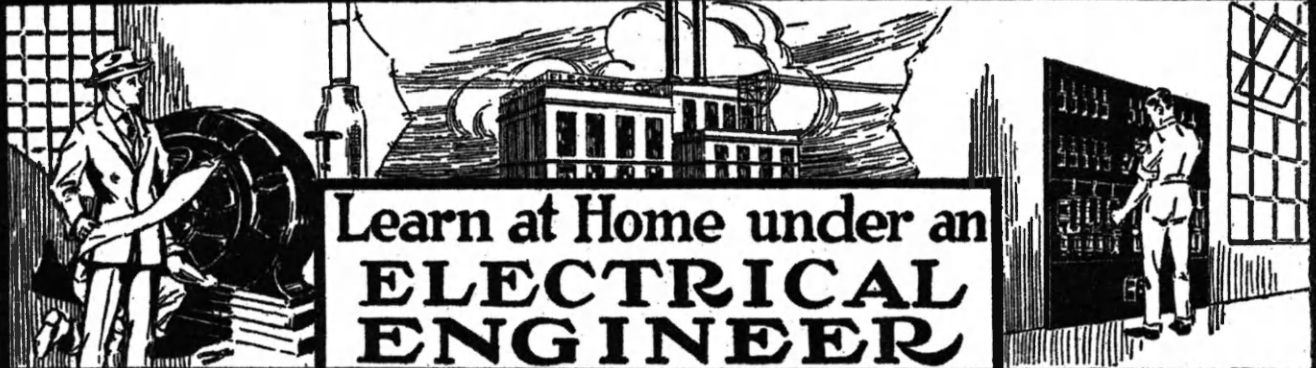

Learn at Home under an
**ELECTRICAL
ENGINEER**

Wicks Trained Men Make Big Money



A. W. WICKS
Elec. Engineer
Formerly with the General Electric Co. Former General Manager of company manufacturing Electric Motors, also formerly with Fairbanks, Morse & Co. Now Consulting Engineer, also Director of the Wicks Electrical Institute.

Electricity, the greatest force in the world—offers you “Big Money” and “Quick Money” if you have the ambition to go and get it. Let me train you in electricity—at home—in your spare time—no matter where you live. I can quickly fit you to qualify as an expert electrician earning \$2000.00 to \$4000.00 a year. You don’t have to go to school. You don’t have to serve time as an apprentice. You start drawing the big pay as soon as you are qualified.

I am an authorized Electrical Engineer. So far as I know I am the only man with the degree of Electrical Engineer to offer a Home Study Course in Electricity. My Electrical Engineering experience has covered a period of twenty-five years with some of the leading engineering and industrial corporations in this country. This wide and varied experience is the secret back of the success of my students.

Qualify to Fill One of These Big Paying Positions	
Chief Electrician	\$300 per month and up
Sub-Station Operator	\$200 per month and up
Electrical Contractor	Unlimited
Maintenance Electrician	\$250 per month and up
Power Plant Supt.	\$200 to \$1000 per month
Electrical Wireman	\$150 to \$200 per month
Meter Tester	\$150 to \$200 per month
Electrical Sales Engineer	Unlimited
Supt. Elec. Installation	\$250 to \$500 per month
Traveling Elec. Inspector	\$200 per month and up

Why Wicks Trained Men Are Successful

Wicks trained men succeed where other men fail because they are trained thoroughly from the ground up. They have been trained under an Electrical Engineer. They have the knowledge gained of 25 years of experience behind them. Wicks trained men can’t go wrong—they know only one way to do things—the right way.

Mail Coupon for FREE Book

Get the Special Rate



New, Easy Method

My new, easy method knocks out all the unnecessary frills and gives you real practical electricity—the money-making facts that you can cash in on. I teach both why and how through practical problems—the kind of problems you will meet later in your everyday work.

FREE Electrical Outfit and Tools

Big outfit containing material, apparatus and tools FREE. I know the value of the right kind of tools, so I want my students to start out with the very tools they will need on the job. This outfit contains everything—there are no extras for you to buy.

Great Opportunities In the Electrical Industry

Just stop and think what electricity means to us in our everyday life and you will realize why there is such a big demand for electrically trained men. The whole world depends on the electrician. Electric Light Companies, Municipalities, Manufacturers and Contractors are paying bigger wages than ever and still need more men to fill big jobs.

A. W. Wicks, E. E., Pres., WICKS ELECTRICAL INSTITUTE
3601 Michigan Avenue, Dept. 7435, Chicago, Ill.

Send the coupon to me today—it will bring you my new big book “Opportunities in the Electrical Field.” If you are interested in your own future you will want this book. I will also send you full particulars of my method of training—show you why Wicks training brings quick success. You will also find out about my Special Tuition Rate now in force. Act at once.

Without any obligation send me your Big New Book, “Opportunities in the Electrical Field” and full particulars regarding your method of training.
A. W. Wicks, E. E., Pres., WICKS ELECTRICAL INSTITUTE
3601 Michigan Ave., Dept. 7435, Chicago, Ill.

Name
Address
City
State

Important Notice

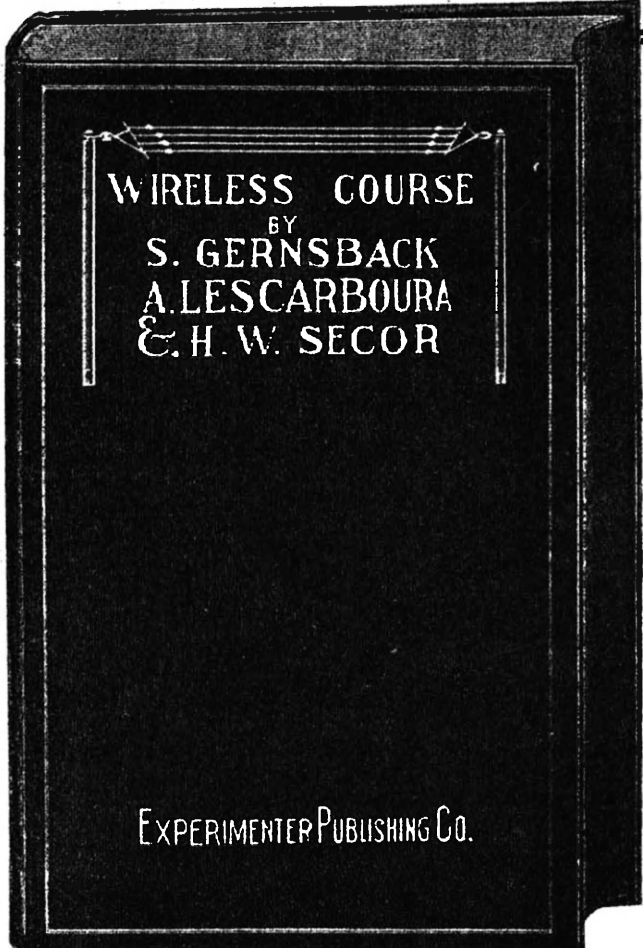

JUST OFF PRESS:

10th Edition

of the well-known

WIRELESS COURSE

in 20 Lessons

By

**S. GERNSBACK, H. W. SECOR,
A. LESCARBOURA**

Beautifully Bound
in Red Cloth
Gold Stamped
Size 7x10 inches
160 Pages
20 Lessons
360 Illustrations
30 Tables

Price \$1.75

PREPAID

THIS Course has been considerably revised in order that it meet some of the many important changes which have occurred in Radio Telegraphy and Telephony within recent years. Much valuable data and illustrations concerning the Vacuum Tube has been added. This comprises the theory of the Tube as a detector and as an amplifier, and in addition has been included modern amplification circuits of practical worth. Incidentally, space has also been devoted to the development of the Radio Compass as operated and controlled by the United States Navy with its consequent great aid to present-day navigation.

The beginner and general student of radio will find this Course of great value in securing the necessary fundamentals of a most fascinating and instructive vocation, or avocation—as the case may be. Radio holds out considerable inducements as a career.

THE PUBLISHERS

**The Experimenter
Publishing Co., Inc.**

**236 FULTON STREET
NEW YORK, N. Y.**

THE EXPERIMENTER PUBLISHING CO., Inc.
236 Fulton Street, New York, N. Y.

Enclosed find \$1.75 in UNIQUE **P.O.** for which send me one copy of 10th EDITION WIRELESS COURSE POSTPAID.

Name _____
Town _____
Address _____
State _____



BOOK REVIEW

WHO'S WHO IN AMERICA, 1920-1921. Vol. II. Cloth covers, size 5½ by 7¾ inches. 3,302 pages. Publish by A. N. Marquis & Co., Chicago.

We have received Volume 11 of "Who's Who in America," a work which has had a long and honorable career, and which really sets the pace for all similar books of contemporaneous biography.

The first volume was for the year 1899-1900 and contained 827 pages with 8,602 biographies. Since then it has grown, the proportional growth being most marked in the early editions. And now, in Volume 11, there are 3,302 pages with 23,453 biographies, of which biographies 2,514 appear in no previous issue. Increasing at this rate, it would seem as if it would surely reach a prohibitive size, but the subjects of its text keep dying, and that is what saves it; because it is a dictionary of only living people. Back references are given to former volumes for those who have died. It therefore is a complete modern American biographical dictionary in its full set of 11 volumes, and any library possessing such a set, should preserve it carefully.

The work has become an absolute standard and is based on the following rule which we quote from the foot of its tenth page, "Not a single sketch in 'Who's Who in America' has been paid for—and none can be paid for."

RADIO INSTRUMENTS AND MEASUREMENTS. Circular No. 74 of the Bureau of Standards, Washington, D. C., 330 pages, fully illustrated. Cloth covers, 7¾ by 4¾ inches. Publish by Wireless Press, New York City.

A volume of over 300 pages, elaborately illustrated with one appendix on the radio of the Bureau of Standards; the second one on the bibliography of the subject; a third one covering the symbols used in the book; and the last one which is by no means to be underestimated in value, as tending to standardize symbols, appears in the very modest guise of a circular of the U. S. Bureau of Standards.

Like everything else coming from that Bureau, it is of a high order of merit, and its range of subjects is such that no advanced radio engineer can afford to neglect it.

A rather full contents may be taken as some sort of an apology for the absence of an index.

SELECTED STUDIES IN ELEMENTARY PHYSICS. A Handbook for the Wireless Student and Amateur. By E. Blake, A. M. I. E. E., 176 pages; illustrated. Cloth covers, 7½ by 4¾ inches. Publish by the Wireless Press, Ltd., London.

This very clever little book written for the wireless student and amateur, with its clearness of statement, its condensing of the subject matter, and in the ground it covers, is so good that it is to be recommended to all students of elementary physics, in the extended sense, because it covers chemistry as well as mechanics and electricity.

We are very glad to recommend it to our readers.

STORAGE BATTERIES SIMPLIFIED. Operating Principles—Care and Industrial Application. By Victor W. Pagé, M. S. A. E. 208 pages, profusely illustrated. Hard cloth covers, 7½ by 5 inches. Publish by the Norman W. Henley Co., New York.

This very timely and fully illustrated book with comprehensive index, gives an excellent presentation of its subject. It is very practical, telling of batteries as they exist and as they are used, both in the acid and alkaline electrolyte construction.

Special instructions for the care and repair of automobile batteries form a valuable feature, and the troubles of batteries (which we all know, are only too many) receive adequate treatment. Major Pagé is no mere theorist, but his years of practical experience give great weight to his text.

WIRELESS TELEGRAPHY AND TELEPHONY. First Principles, Present Practise and Testing. By H. M. Dowsett, M. I. E. E. 331 pages, clearly illustrated. Hard cloth covers, 8½ by 5½ inches. Publish by Wireless Press, Ltd., London.

This book publish by the Wireless Press, who are also the publishers of Mr. Blake's

Electrical Books Sent to You For One Week FREE

Here are the world's greatest Electrical Books. You can have them for a weeks' Free use in your home or shop. Eight big books, 4000 pages of money-making facts. More than 3000 pictures, blue prints and diagrams that make everything clear as day. Prepared by 28 of the world's master electrical minds in plain every day English that any one can understand. They teach you electricity from the ground up. They explain everything—from the simple wiring of electric bells to the mighty electric machinery you see in the power houses. They save you the money it would cost to go to an electrical school. They save you years of hard work as an apprentice. Old-time electricians say "they are the finest books they ever saw." See our free trial—easy payment offer below.

Master These Subjects

Principles of Electricity; Telephones; Construction. Operation and Repair Dynamos and Motors; Storage Batteries; Alternating Current Machinery; Switch Boards; Armature Winding; Construction and Operation of Transformers; Electrical Measurements; Electromagnets; Induction Coils; Controllers; Electric Elevators; Railway Signaling; Interior and Exterior Wiring; Materials and Methods Used; Underwriters' Requirements; Electric Lighting; Planning Systems; Estimating; Contracts; Specifications; Maintenance; Electrochemistry; Power Stations; Operation and Maintenance; Management of Dynamos and Motors; Electric Welding; Electric Transmission Lines; Distributing Systems; Electric Railways; Construction of Power Plants; New Electrical Devices.

Get in the Big Money Class Electricians Earn \$60 to \$100 a Week

The electrical field is seriously under-manned. Thousands of men who know what's what are needed right now to fill important jobs such as Sub-Station Operators, Switch-board Operators, Dynamo and Motor Tenders, Installation Experts, Trouble Men and Engineers. The work is fascinating and the pay is big.

Your Future Is in Electricity

Electricity is the greatest force in the world and it is growing greater every day. The whole world depends on the electrician. Think what opportunities this offers to the fellow with a little ambition. You can succeed in electricity. You can have a big job and the big pay that goes with it. These books will show you the way.

Don't Send Money

Prove to yourself how easy it is to master electricity by getting these books for a weeks' free use. Just mail the coupon and the whole set will come to you at once. If you don't like them—if you don't think they will do for you what we claim—send them back at our expense and you won't owe us a cent. If you are satisfied with the books in every way just send us \$2.80 as first payment and \$3.00 each month, until \$34.80 is paid. This is only a dime a day. Most of us waste more than this. Mail the coupon now and get a membership in this Society, Free.

Mail Coupon For These 8 Big Books

AMERICAN TECHNICAL SOCIETY
Dept. E-255, Chicago

Please send me a set of Practical Applied Electricity in 8 volumes by express collect, for a week's free use. At the end of a week I will either send the books back at your expense or send you \$2.80 as first payment and \$3.00 each month thereafter until a total of \$34.80 is paid. I understand that I will get a consulting membership in your Society, FREE with the books.

Name

Address

Reference





Headquarters for Campers' and Tourists' Supplies

CARNIE-GOUDIE CO.
(Established 1908)
Kansas City, Mo.

WE have everything for Campers, Hunters, Tourists, Boy Scouts and Camp-fire Girls at lower prices than ever before. Order direct from this advertisement. Big purchases direct from the government. Saves you one-half or more on every purchase! A splendid stock of goods that will go fast. Order now! Money back if not satisfied.

100—Turo-Camp Tent. Very fine Olive Drab Army Duck. Almost good as new. Comes in two sections. Buttoned together making tent 7x12 with 2 13-ft. sidewalls. Half section can be attached to auto. Complete with poles as shown in above illustration. **Price delivered..... \$26.75**

101—One section Complete with poles. **Price delivered \$13.95**

200—Army Wool shirts, Olive Drab, best quality wool shirting. Thoroughly washed and repaired. **Price del. \$2.65**

New Army Shirts 200 1-2-Brand New G. D. as illustrated. Cost over \$5 wholesale. **Special \$4.95**

554—New Flannel Shirts from French Army. Bines and grays with pin stripes. Two large pockets. Reinforced elbows. Collar fastens with special patent links. A very dresy sport shirt. **Special Price delivered \$4.95**

No. 197—New Olive Drab Cotton Shirts. Light and durable. The regulation khaki. Cost the government over \$2 in million lots. **Our Special price, del. \$1.97**

571—New Hip Rubber Boots. Extra heavy solid rubber extension soles. Reinforced throughout. Uppers extend to hips and fasten with rubber strap. Give size. **Price delivered \$4.95**

556—Army Officers Leather Puttees. Mahogany leather beautifully finished. Fine for riding, hiking, etc. Less than half price. **Special \$4.95**

137—Genuine O. D. Army Blankets. Best you can buy. Reclaimed by government methods. Practically like new. Genuine wool. For camping, touring, etc. **Price delivered..... \$7.05**

111—Army Coat. O. D. Cotton. Reclaimed and lanndered. Fine for work, outing, etc. Saves good clothes. Give size. **Price delivered \$4.95**

112—Army Breeches. O. D. Cotton. Thoroughly required. A bargain for everyday work, outing, hunting, etc. **Price delivered 85c**

199—Genuine Shelter "Pup" Tents used by Yanks in France. Just the thing for hunters, campers, hiking trips. Water-proof. Complete with poles, etc. **Price delivered..... \$3.75**

114—Army Raincoat. Purchased from government in large numbers. Made of waterproof khaki cloth. Black metal fasteners. Slightly used but good condition. **Price \$8.95**

99—Pyramidal Tent, Khaki or white. Sz. 16x16; 8 ft. side walls; 11 feet center. In splendid condition. Wonderful for touring, camping, summer use. Complete with poles and stakes. **Price delivered..... \$33.75**

281—Military Luggage Carrier. All steel and collapsible. Fits any car. Adjustable length from 27 inches to 4 ft. Doesn't rattle. When not in use folds neatly on running board. **Special Price, delivered \$4.95**

Gas Mask Bag made of heavy water-proof canvas. Just the thing to carry your supplies. **Price.....57c**
Army Knives \$1.27
Spiral Leggins, new..... 95c
Army Mess Kits 75c
Military Axes \$1.25

Money Back Guarantee—Every article sold on our Satisfaction or Money Back Guarantee. You take no risk. Order from this ad. Send for Free Catalog of Bargains.

CARNIE-GOUDIE COMPANY
Dept. S. I. KANSAS CITY, MO.

Complete Catalog of Supplies for Campers and Tourists

comprehensive little work, gives an excellent resume of up-to-date wireless work.

Wireless telegraphy and telephony are changing from day to day. There is, of course, a feeling that with the introduction of the vacuum tube, wireless has reached its last development. But this is a very unsafe statement, so manuals like the one under review, up-to-date in their subject and sufficiently detailed in their descriptions, are certainly to be welcomed and in a way are more useful than larger and more elaborate works would be.

ELECTRICIANS' HANDY BOOK. A Modern Book of Reference. By T. O'Connor Sloane, A. M., E. M., Ph. D. 823 pages, numerous illustrations. Cloth covers, 6 1/4 by 4 1/2 inches. Publish by the Norman W. Henley Co., New York.

This work has had a long career and the present edition is brought up-to-date by an addition covering the recent developments in electrical science. Such topics as electric furnaces, electric bleaching, the pupinization of land line and submarine cables, lifting magnets, metallic filament lamps and modern treatment of wireless telegraphy appear in the new portions of the book.

WIRING FOR LIGHT AND POWER. By Terrell Croft. 465 pages, fully illustrated. Leatherette covers, 7 3/8 by 4 1/2 inches. Publish by McGraw-Hill Book Co., Inc., New York.

Mr. Croft's booklet is written as a comment upon or an enlargement of the National Electric Code. This code has been instituted for the protection against fire and accidents. And it is quoted, section by section, thruout the book, and statements follow the sections, telling how its regulations should be carried out, with numerous illustrations to make the descriptions clear.

The index is so full that it would be safe to refer anyone to it, as an example of how a scientific work should be indexed, while the absence of an index is always to be condemned—some are such poor apologies that they are very little better than none.

TEXT-BOOK OF EXPERIMENTAL PSYCHOLOGY—PART TWO. Laboratory Exercises. By Charles S. Meyers, M. A., M. D., Sc. D. 107 pages, 44 illustrations. Cloth covers, 8 3/4 by 5 1/2 inches. Publish by Longmans, Green and Co., New York.

Laboratory exercises in what is called "experimental psychology" a subject which has an unsuspected way of merging into physiology, is treated elaborately in this book with numerous illustrations, the whole being arranged in numbered sections.

Professors have found that the psychologic examination of students is really very useful in determining the course to be pursued in their studies. Especially is this the case with young pupils.

The present work, however, is quite highly developot and goes into the minutia of the subject, with the application of plain and simple apparatus. The psychology of the author, we regret to say, is such that he has given no index.

PRINCIPLES OF RADIO TELEGRAPHY. By Cyril M. Jansky, B. S., B. A. 242 pages, profusely illustrated. Cloth covers, 8 3/4 by 5 1/2 inches. Publish by the McGraw-Hill Book Co., Inc., N. Y.

The fundamental principles underlying radio telegraphy are at the base of its treatment in Prof. Jansky's book.

Numerous formulæ and adequate mathematical treatment of the subject go to make the book a standard. It is a great mistake to endeavor to avoid mathematics in the study of modern electricity and their use in the present work gives it much value and at the same time it is to be noted, that the same mathematics are kept well within the range of knowledge of the elementary student of electricity; higher mathematics are not utilized. All that is needed on the part of a student is a knowledge of simple algebra.

Much of this book may be read with advantage by any electrical student because the technique of radio work fills less than one-half the work.

HOUSEHOLD PHYSICS. By C. H. Brechner. 304 pages. Profusely illustrated. Cloth covers, 7 1/2 by 5 inches. Publish by Allyn and Bacon, Boston.

The practical element of this book is indicated by its frontispiece, which shows four attractive young women studying the operation of a washing machine and wringer. The frontispiece, like the title of the book, gives a clue to the ground it covers, altho it is fair to say that it passes outside the limits of its subject in a way which really adds interest to it.

The book was written primarily for girls. Examples and references with which they are supposed to be thoroely familiar are used. It was said that the work was developed in the classroom.

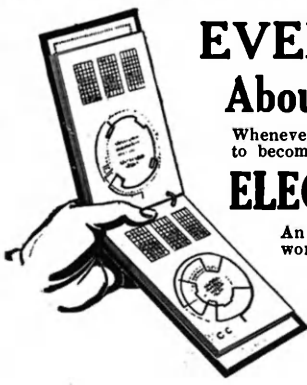

EVERYTHING You want to know About A. C. Motors and Repairing

Whenever any question arises regarding motors, or if you are anxious to become a specialist on electrical motor work, you need the

ELECTRICAL WORKERS FRIEND

An invaluable collection of diagrams and instructions for electrical workers, students, amateurs, etc. This book contains 66 motor diagrams with complete instructions for rewinding and reconnecting A. C. Motors. Shows how to put each coil in the slots, give all internal and external connections. For reconnecting they cover all practical changes showing which diagram to use for the change wanted. Bound in loose leaf form for

handy reference. The only complete book of its kind on the market. So simple anyone can understand. It is helping thousands of other workers—it will help you too, as hundreds of testimonials prove.

SPECIAL PRICE, COMPLETE \$4.00. Order today. If desired we will ship C. O. D. by Parcel Post, U. S. only.

YOU CAN EARN YOUR COPY FREE

We offer all owners of the Electrical Workers Friend a commission of 50c on every book they help us sell. All you have to do is show your book and recommend it. You can earn the full price of one of these books in a few days. Write immediately for full particulars—this offer is limited.

SMITH & SMITH PUB. CO. 1524 Lowrie St., N. S. Dept. B, Pittsburgh, Pa.

Heat, sound, light, color, electricity, mechanics, et cetera, are some of the leading topics, and numerous problems for solution by the students, are embodied in the text. We believe there are many college men who would be enlightened by going thru this book, which the modesty of the author seems to appraise at a lower standard than it really deserves. We take pleasure in recommending it to our readers.

THE AMERICAN BOYS' ENGINEERING BOOK. By A. Russell Bond. 309 pages, 232 diagrams. Stiff cloth covers, 8¼ by 5½ inches. Published by J. B. Lippincott Co., Philadelphia, Pa.

This excellent work covers a range of subjects, shop work, the home production of machines, tools for the work shop, surveying, roads, railroads and many other engineering topics, and goes on to electric power and astronomy. We should think this would be a welcome addition to the library of a mechanically disposed boy.

Mr. Bond is well known from his connection with the "Scientific American" and like any really good book of its type, there is much in it which can be read with profit by the average adult.

Quite an interesting chapter is devoted to Weather Bureau work.

ELEMENTARY ELECTRICITY AND MAGNETISM. Their Applications. By Jackson and Black. 598 pages, clearly illustrated. Cloth covers, 7½ by 5 inches. Published by the Macmillan Co., New York.

This book is a new edition of Jackson and Black's "Electricity and Magnetism," first published in 1902.

All that need be stated about it is that it presents an excellent treatment of its subject; that problems inserted in the text elucidate the subject; and that each chapter is followed by a summary in full in heavy face type with a list of questions.

The illustrations are numerous and there are several interesting portraits of the early workers in this science.

SELENIUM CELLS—The Construction, Care and Use of Selenium Cells with Special Reference to the Fritts Cell. By Thomas W. Benson. 63 pages, fully illustrated. Cloth covers 7½ by 5 inches. Published by Spon & Chamberlain, New York.

There are so many people interested in selenium and its possibilities that this little manual with very full contents (but which we are sorry to say has no index) with numerous illustrations, appears very timely.

MAGNETISM AND ELECTRICITY FOR HOME STUDY. By H. E. Penrose. 515 pages, well illustrated. Cloth covers, 7½ by 4½ inches. Published by the Wireless Press, Ltd., London.

The subject of electricity is given in this book, in what the author terms, "a series of lessons"; but no pains are spared to clarify the subject. The forty-nine lessons cover the entire subject of electricity pretty thoroughly, and at the end of each lesson are given questions.

The use of full face type in the text, while not conducive to typographical attractiveness, is made here to serve a useful purpose and to really make the work of increased value to the student by a species of visual effect.

THE MYSTERY OF SPACE. A Study of the Hyperspace Movement and an Inquiry into the Genesis and Essential Nature of Space. By Robert T. Browne. Illustrated. Cloth covers, size 5½" by 8¼", 395 pages. Published by the E. P. Dutton Co., New York.

Many peculiar books, to say the least, have appeared in recent years, devoted to what is known as "the Fourth Dimension, and non-Euclidean geometry." This work starts really on rather a serious basis. It begins with an introduction composed of a series of definitions and biographic notes alphabetically arranged, and then the book proper follows. The definitions, of course, are peculiar, and among them are some curious words.

A sketch of the hyperspace movement opens the real text, in which very properly appear the names of a great many philosophers and notes on their work. The essentials of non-Euclidean geometry dimensionality follow, and then comes a page on the fourth dimension.

The essential nature of space and all of its many attributes, including what is termed "the mystery of space," comparable really to the mystery of infinity, are treated at length. One chapter is devoted to what is very modestly termed "near truths." New Perspective Faculties are treated upon in the last chapter, followed by a brief biography and a satisfactory index.

40 Years of Progress with Fine Tools

"-when typewriters were curiosities"

Forty years ago, when the typewriter was still a "new-fangled contraption," machinists were beginning to learn what so many thousands know today—that Starrett Tools are made to insure complete satisfaction to the men who use them.

"Tools just a little better than were ever made before" was the Starrett idea in 1880. It is the same in 1920. That explains why Starrett Tools have had so big a share in the industrial development of the country.

If you're interested in fine tools write for a copy of Catalog No. 22 "LE."

THE L. S. STARRETT COMPANY

The World's Greatest Toolmakers
Manufacturers of Hack Saws Unexcelled
ATHOL, MASS.



1920



Use Starrett Tools



WURLITZER
200 YEARS OF MUSICAL INSTRUMENT MAKING

On Trial

ANY instrument sent with complete musical outfit, for a week's free trial at home. No obligation. Return it at our expense after trial if you wish. Outfit includes velvet lined case, self instructor, music and all accessories at factory cost. A tremendous saving.

Monthly Payments
A few cents a day will pay. Wurlitzer instruments are known all over the world for artistic quality. Every instrument known, including pianos and Victrolas included in this plan.

Send for Catalog
All instruments illustrated with price, easy terms and free trial blank. Catalog free. No obligation. Send coupon now.

The Rudolph Wurlitzer Co. Dept. 185, 117 East Fourth Street, Cincinnati, Ohio
329 S. Wabash Av., Chicago; 120 W. 42nd St., New York

Send me your new catalog illustrated in color with details of Wurlitzer Complete Outfits, free trial and easy payment offer.

Name.....Address.....
.....State.....

Musical instrument in which I am especially interested.

SPECTACULAR TESLA EXPERIMENTS
HIGH FREQUENCY CURRENTS

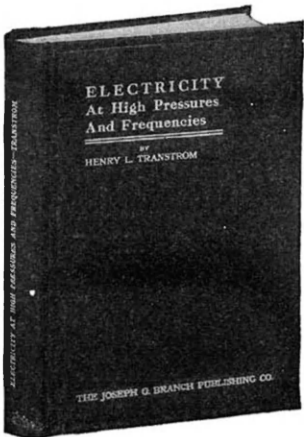

Second Edition

A Fascinating Book that Every Experimenter Needs

The book itself is well written, explaining all the fundamentals of high frequency currents, devoid of any obtruse mathematics and technicalities which would only hamper the average student.

Printed in large type, 266 pages, 141 original illustrations, bound in stiff paper, \$2.50, postpaid; or, in cloth, \$3.00, postpaid.

Order Your Copy To-day

THE JOSEPH G. BRANCH PUBLISHING CO.

3800 Lake Park Ave., Chicago, Ill.

DIRECT CURRENT MOTOR AND GENERATOR TROUBLES. Operation and Repair. By Theodore S. Gandy and Elmer C. Shact. Profusely illustrated. Cloth covers, 5 1/2" by 8 1/4", 274 pages. Publish by the McGraw-Hill Book Co., New York.

The best reason for accepting the value and merit of this book lies in its introduction, which does more to establish its worth than anything we can say in our columns. It is because the introduction is a commendation and encomium written by Dr. Charles P. Steinmetz. This is an ipse-dixit in the electrical world and leaves nothing more to be said.

With numerous illustrations, the data on motors and generators for organization and assembly and for starting and operation, take about one-half the book. When in the seventh chapter, troubles and their remedies are reached and are exhaustively treated, then approved remedies and finally a treatment of tests and repairs are given. A final section gives what the author terms "useful data" which are very practical and a very satisfactory index closes the work.

THE NEW SCIENCE OF THE FUNDAMENTAL PHYSICS. By W. W. Strong, Ph.D. Cloth covers, 6" by 9 1/4", 107 pages. Publish by the S. I. E. M. Co., Philadelphia, Pa.

The "new" science in this book is defined as a more complete application of physics to the basic units, measurements and laws of science. It appeals very strongly to experimenters. Non-Euclidean geometry is also appealed to, and many interesting topics, such as the disappearance of energy, the ionization phenomenon, the atomic structure of matter, the disintegration of atoms; atom models and atom nuclei are suggestive topics.

The relativity theory is briefly treated in the last chapter, and the book unfortunately lacks an index.

THE ROSICRUCIAN MYSTERIES. The Rosicrucian Fellowship. By Max Heindel. Cloth covers, 5" by 7 3/4", 192 pages. Publish by the Rosicrucian Fellowship, Oceanside, Calif.

The order of the Rosy Cross has been the subject of various pieces of literature in the English language and here we have a serious book supposed to be devoted to the teachings of the Rosicrucians. One of the peculiar things about it is, that the author seems to know more about the after-world than most of us do.

PHOTO-ENGRAVING PRIMER. By Stephen H. Horgan. Cloth covers, 5 1/2" by 8", 81 pages. Publish by the American Photographic Publishing Co., Boston, Mass.

The author of this book is one of our distinguished authorities on all classes of photo-engraving. It is enough to say that the book is by him, to recommend it. He endeavors to give and succeeds in giving a simple yet practical knowledge of line and half tone engravings for the beginners in the art. But it is fair to say that there are few, however experienced, who will not find much to interest them and a great deal which will be new even to those who understand this subject.

One thing may be noted as an example of how this work is done,—and that is, where temperatures are given, both Fahrenheit and Centigrade are printed. Numerous formulae are contained in the book, and the most practical kind of methods are given for the application thereof. A very nice glossary of terms with a quite adequate index ends the book, which we recommend to all interested in this art.

MODERN WELDING METHODS. By Victor W. Pagé, M.S.A.E. Well illustrated. Cloth covers, 5 1/2" by 8 1/4", 292 pages. Publish by the Norman W. Henley Publishing Co., New York.

Major Pagé with his long experience in the automobile and airplane world, in which service part of his time was past in France with the American Army, gives anything that he writes on this subject exceptional value.

Oxy-acetylene welding and cutting are first treated. This is followed by the two types of electric welding, the resistance welding in which incandescence is produced by the passing of current thru metal, and the other in which the arc is used. After this comes thermit which is one of the most impressive developments in autogenous welding, where, because of it, the largest kind of operation can be performed virtually in a few minutes, if we omit consideration of the pre-heating.

Under these Goldschmidt processes some most wonderful work has been done, altho, of course, so much has really been effected by science within the last two decades, that we bid fair to lose the power of wondering.

We notice one or two errors in the spelling of proper names of foreign scientists, but these are far from vital.

The illustrations are particularly commendable and certainly make modern welding processes very impressive. Two very acceptable additions to the work touch on soldering and brazing; on the old process of forge welding; and on heat terms of metals. There is a full index.

\$2.00 BRINGS A Satisfactory Tire

Save One-Half

Size	Tires	Tubes	Size	Tires	Tubes
28x3	\$5.25	\$1.50	34x4	\$8.75	\$2.60
30x3	5.50	1.60	34x4	10.00	3.00
30x3 1/2	6.50	1.75	35x4 1/2	11.00	3.15
31x3 1/2	6.75	1.85	35x4 1/2	11.50	3.40
32x3 1/2	7.00	2.00	35x5	12.50	3.50
31x4	8.00	2.25	35x5	12.75	3.65
32x4	8.25	2.40	36x5	12.75	3.75
33x4	8.50	2.50	37x5	12.75	3.75

Special offer on "SATISFACTORY" reconstructed double tread tires. Each tire guaranteed. Refiner free with every tire, also a new Miller inner tube at factory price.

State size, also whether straight side, clincher, plain or non-skid. Send only \$2.00 deposit for each tire, balance C.O.D. subject to examination. Orders shipped day received. Extra 10% discount for full cash with order. Order NOW.

SATISFACTORY TIRE & RUBBER COMPANY
2941 S. Michigan Blvd., Dept. 62 Chicago, Ill.

Small Cash Payment Starts You Making Big Profits Charging Batteries

BUY YOUR H B CHARGER ON EASY MONTHLY TERMS

You have almost a year to pay for any H B Charger. Thousands in use piling up big cash profits for owners. \$1500 to \$3000 clear profit a year. Sizes for charging 10, 16, 32 or 70 batteries at once. Sold on absolute money-back guarantee. Choose size you need then write for information

Hobart Bros. Co.
Box 577E, Troy, O.
Canadian Distributors, Battery Service & Sales Co., Hamilton, Ontario

You Can Clear \$150 to \$300 Monthly

LUCKY RING ON 7 DAYS TRIAL

Believed by many to be a Charm of Good Luck. The Horseshoe Top is Solid Gold and the Nail Solid Silver, set with Genuine Garnet. It is odd, unique, attractiv., admired by everybody. Send your name, address and ring measure (strip of paper around finger). When you receive Ring, pay \$4.98. Wear it seven days and follow the seven golden rules which come with Ring. All your money back if not fully satisfied.

KOSMOS CO., Dept. 36 828 North Clark Str., Chicago

\$4 AND \$5 WILL BUY a month A Standard, Guaranteed TYPEWRITER

With Every Modern Writing Convenience

WRITE TODAY FOR ILLUSTRATED CIRCULAR Explaining Try-Before-You-Buy Plan

HARRY A. SMITH, 738-218 North Wells St., Chicago, Ill.

Do Your Own Soldering and Metal Repairing with SOLDERALL 25 cents

Patented Oct. 3, 1911

A Paste That Turns Into Metal When Heated

A match will do it. Requires no acid or soldering iron. Joins or repairs wires, metals or metalwares.

SOLDERALL CO., Dept. E 129 Sussex Ave., Newark, N. J.

Combination Belt

Keeps Trousers \$300 Up, Shirt Down!

This "Serviceable" Combination Belt keeps your trousers up—firm and smooth without belt or suspenders. Positively prevents slipping, no binding or discomfort. Invaluable peak ribbed protector near waistline. Once adjusted always fits. Send waist measure and \$3.00—belt will be sent postpaid. \$4.00 value. Money-Back Guarantee. Catalogue FREE. Fine for Athletic Men. 100,000 users. Write TODAY.

Serviceable Mfg. Co., Dept. C-530 N. Michigan Ave., Chicago

WRITE IT WITH A "VULCAN"

Red or Black Vulcan Ink Penell

The only perfect, non-leakable ink penella at moderate prices.

Efficiency, economy, no binding or discomfort. Order today, Postpaid 45c

Absolute necessity to any business man or woman. Promotes efficiency. Unequaled for general writing, signing, routing and manufacturing. Made of pure vulcanized rubber, non-corrosive, durable, writing point. Lock-Cap prevents leaking. Extra size, 8 ins., black only, \$1.75. Agents Wanted. Big Profits.

J. F. ULRICH & CO., 161 Washington St., N. Y.

Double Your Mileage Save Your Money

Long Wear Double Tread Tires have double thickness, which insures them against punctures and blowouts, also weather proof. These tires are guaranteed on a 6,000-mile basis, but often give the user 8,000 miles. Take advantage of this great offer and order at once while our stock is complete.

Size	Tire	Tube	Size	Tire	Tube
30x3	\$6.00	\$1.75	34x4	\$ 8.25	\$2.65
30x3 1/2	6.00	1.75	34x4 1/2	9.75	2.75
32x3 1/2	6.50	2.05	35x4 1/2	10.00	2.75
31x4	8.00	2.35	36x4 1/2	10.50	2.75
32x4	7.75	2.45	35x5	11.25	2.75
33x4	8.00	2.50	37x5	11.75	2.85

When you order, state whether you want straight side or clincher, plain or non-skid tires. Send \$3 deposit for each tire ordered, balance C. O. D. subject to examination. We allow a special discount of 5 per cent if you send full amount with order. Refiner free with every tire. We ship the same day order is received.

LONG WEAR TIRE WORKS
Dept. A-31 3817 W. Harrison St., Chicago

Build Your Own PHONOGRAPH

IT'S EASY WITH OUR HELP. A few hours interesting work saves over half and gives you a machine to suit your ideas. We furnish motors, tone arms, case material, blue prints and full instructions. Plays any record. Make fine profit building phonographs for your friends.

Write today for our **FREE** Blue print offer.

AGENTS wanted for Choralon King Phonographs

Choralon Phonograph Co.
521 3rd St., Elkhart, Ind.

SAVE OVER HALF



PATENT ADVICE

Edited by
H. Gernsback

In this Department we publish such matter as is of interest to inventors and particularly to those who are in doubt as to certain Patent Phases. Regular inquiries address to "Patent Advice" cannot be answered by mail free of charge. Such inquiries are published here for the benefit of all readers. If the idea is thought to be of importance, we make it a rule not to divulge all details, in order to protect the inventor as far as it is possible to do so.

Should advice be desired by mail a nominal charge of \$1.00 is made for each question. Sketches and descriptions must be clear and explicit. Only one side of sheet should be written on.

TELEPHONE TRANSMITTER

(434) Henry Goldblatt, Chicago, Ill., enters a drawing of a telephone transmitter having an electro-magnetic core, which in turn acts upon iron filings; the latter constituting the transmitting granules, and supposedly take the place of the carbon granules in an ordinary transmitter. He adds: This transmitter will be 95% perfect.

A. In the transmitter which you have designed, you are defeating the purpose, because what is desired is a change of electrical resistance due to the compression and decompression of the carbon granules in the transmitter. If this transmitter is filled with iron filings, the compression and decompression sets up changes in electrical resistance which in turn magnetizes and demagnetizes the iron core and creates a secondary compression and decompression in the iron filings of the transmitter, and therefore will constantly give you a sort of echo, a very undesirable element for proper speech transmission, and therefore we do not believe that the transmitter which you have designed will be 95% perfect as claimed by you.

DUMPING AUTO-TRUCK.

(435) Norman J. Harvey, Wayne, Nebr., forwards specifications of an automatic dumping automobile truck.

A. The scheme which you have advanced is not new and is used every day in New York City and perhaps many other large towns.

It will undoubtedly become universal after a time. In New York City practically no trucks are unloaded manually. Some are provided with chutes to release coal, grain, etc.; some are automatically dumped by means of a piston arrangement driven by the motor, which pumps oil into the piston cylinder and raises it the same as is the case in many hydraulic elevators. Other trucks operate on a cable principle, some by levers, and some by the arm and worm gear, as described by you.

We doubt if you can obtain a broad patent on such a principle.

AIRPLANE BOMB DROPPER.

(436) Adolph A. M. Korn, Chatworth, Ill., submits a U. S. Patent No. 1196834, of a tubular bomb dropper for airplanes with a sighting device parallel with the barrel of the bomb dropper.

A. Just at the present time you will probably find it rather difficult to dispose of your invention of a bomb thrower for airplanes.

Obviously, you have overlooked the most important feature, that when an airplane drops a bomb, no matter how accurately it is set, the course of the bomb will not be straight down to the earth,—but the bomb will proceed forward to a certain distance and fall in a curve, according to Newton's law of motion.

Therefore a sight in parallel with the barrel of the bomb dropper will be of no practical value. A little experimenting on your part would have brought this fact to light.

RIFLE AND NOVELTY.

(437) C. Hewes, Staunton, Va., sends a drawing of an automatic repeating rifle made with a barrel similar to a revolver, and another of a toy smoking figure or mannikin.

A. We do not believe that a patent on the automatic repeating rifle would be of any great value as it would not be accurate at the best, and could not be produced so as to be both serviceable and cheap. There are many such systems now employed, but which are not looked upon favorably by the riflemen.

In reference to your second device we would certainly advise a patent on the same. The scheme is novel, unique and commercially practical, and undoubtedly if handled successfully, might be very profitable. It certainly would find its way into many households, particularly in view of the fact that perfumes and essences could

be made up cheaply, because they are being rolled up into cigarette form and a blower automatically creates a draft. The idea is undoubtedly one of the best which we have seen for a long time, and we would advise that you get in touch with a patent attorney immediately.

We would advise that the clock work be contained within the same figure, and that the key be so disguised as to represent a cane or a button so as to make it practically unnoticeable.

MOULDING COMPOUND.

(438) A. LeDuc, Everett, Washington, says: I have made compounds similar to Redmanol for moulding objects, etc., can I manufacture such moulded articles?

A. Redmanol, Formalite and Bakelite are all thoroly covered by patents, and for that reason, you could not use and manufacture devices having similar formulas, unless your formula differs materially, or unless you can ascribe a different feature to compounds which you are moulding.

We believe that you will run chances of having a patent suit brought against you. It is an easy matter to obtain copies of patents covering these compounds, and also the processes for the manufacture of the same by writing to the U. S. Patent Office, Washington, D. C.

TIRE ILLUMINATOR.

(439) Edu Milligan, Casper, Wyoming, places lights in the recesses in the bumper so that tire changes may readily be made.

A. Altho the idea which you have evolved, namely, that of employing lights in the bumper of an automobile to throw a beam of light upon the wheels if making tire changes at night, is quite practical and feasible, it is so simple that we doubt very much whether a basic patent could be obtained on the same.

There are many drawbacks and hindrances to a patent on such a device. In the first place, a different type of bumper will have to be employed and therefore, anyone who makes a simple attachment to the bumper, will have evaded your patent claims. In the second place, the ordinary spotlight, with which all automobiles are fitted, answers the purpose very well, and can be used as a trouble lamp for engines as well. In the third place, lamps on the bumper are susceptible to breakage much more so than on any other part of the machine, and therefore, the upkeep will be considerable.

In view of these hindrances, we do not believe that a patent obtained on such a system will be of commercial value, altho it is quite possible that a patent could be secured.

U.S. PATENTS



SEND FOR THIS FORM

Don't Lose Your Rights

Before disclosing your invention to anyone send for blank form "Evidence of Conception" to be signed and witnessed. A sample form together with printed instructions will show you just how to work up your evidence and establish your rights before filing application for patent. As registered patent attorneys we represent hundreds of inventors all over the U. S. and Canada in the advancement of inventions. Our schedule of fees will be found reasonable. The form "Evidence of Conception" sample, instructions relating to obtaining of patent and schedule of fees sent upon request. Ask for them,—a post card will do.



255 OURAY BLDG.,
WASHINGTON, D. C.

"Originators of form Evidence of Conception"

PATENTS

TO THE MAN WITH AN IDEA

I offer a comprehensive, experienced, efficient service for his prompt, legal protection and the development of his proposition.

Send sketch, or model and description, for advice as to cost, search through prior United States patents, etc. Preliminary advice gladly furnished without charge.

My experience and familiarity with various arts frequently enable me to accurately advise clients as to probable patentability before they go to any expense.

Booklet of valuable information and form for properly disclosing your idea, free on request. Write today.

RICHARD B. OWEN, Patent Lawyer
164 Owen Building, Washington, D. C.
2276-8 Woolworth Bldg., New York City

PATENTS TRADE-MARKS AND COPYRIGHTS

Before disclosing an invention, the inventor should write for our blank form "EVIDENCE OF CONCEPTION." This should be signed and witnessed and if returned to us together with model or sketch and description of the invention we will give our opinion as to its patentable nature. Electrical cases a specialty.

Our illustrated Guide Book, "HOW TO OBTAIN A PATENT," sent Free on request. Highest References Prompt Attention Reasonable Terms

FREE COUPON

VICTOR J. EVANS & CO., Patent Attorneys

Chicago Offices:
1114 Tacoma Bldg.

Pittsburgh Offices:
514 Empire Bldg.

Philadelphia Offices:
135 S. Broad St.

San Francisco Offices:
Hobart Bldg.

New York Offices: 1001 Woolworth Bldg.

MAIN OFFICES: 779 NINTH, WASHINGTON, D. C.

Name..... Address.....

U.S. PATENTS

PROTECT YOUR RIGHTS

RECORD OF INVENTION

Send sketch and description for report upon patentable nature and instructions. Preliminary service without charge.

PROMPT PERSONAL - SERVICE

J. REANEY KELLY

PATENT ATTORNEY

892 SOUTHERN BLDG. WASHINGTON D.C.

CAN YOU

think of a simple, practical idea that will fill one of the many requests we have on file for new inventions? It may mean a fortune for you. Thousands of things are needed **RIGHT NOW**. Your brains can help. Send today for our great new book—"Inventions and Trade Marks, Their Protection and Exploitation" and learn more about making money from ideas than you ever knew before. It tells many things that are wanted, too. A postal will do—**it is free.**

We help our clients, without charge, to get the dollars out of their ideas—having facilities none others possess.

Advice free. Don't delay—get the book at once.

AMERICAN INDUSTRIES, INC.

225 Patent Dept., WASHINGTON, D. C.

PATENTS ADVERTISED For SALE FREE

In INVENTION And MANUFACTURING SUPPLEMENT.

Published for the man with an idea. Send for free sample copy. One year's subscription 50c

PATENT SENSE

The Book for INVENTORS and MANUFACTURERS

SIXTH EDITION

The Book for Inventors and Manufacturers

SIXTH EDITION.

By return mail **FREE**. Write **LACEY & LACEY** Dept. K, Washington, D.C.

PATENTS

Send sketch or model for preliminary examination. Booklet free. Highest references. Best results. Promptness assured. Watson E. Coleman, Patent Lawyer, 624 F St., Washington, D. C.

VIOLIN VARNISHING METHOD.

(440) Monroe Wills, Dry Creek, W. Va., says: I am sure that I have resurrected the method of varnishing violins as employed by the Italian masters. Can I get a patent on it?

A. If you have a distinctly novel method of polishing and varnishing violins, which has not been published heretofore, you undoubtedly can secure a patent on the same.

However, the fact that you suggest that you have resurrected the Italian method, on the face of it indicates that you have, thru manuscripts or otherwise, learned of a method used long ago, and which you are again trying to bring to the front. This would be unpatentable.

You will have to be sure that it is the method, and not the varnish which is radically different from any of the other methods now so extensively employed, which causes this system of varnishing to be of such extreme value. A varnish may also be patented and a trade mark applied to protect its name.

RESISTANCE FURNACE.

(441) Douglas McHenry, Minneapolis, Minn., submits a variable, resistance furnace with renewable units and asks our opinion.

A. Your idea is indeed very clever, and we see no objection to its use. Such a furnace as you have described would be of advantage and undoubtedly far surpasses the types using resistor units in that it is much cheaper and easier to control.

Perhaps some method of snapping these resistance tubes of your type into place would be an advisable change, as that would naturally increase the speed of replacing the resistances.

We do not doubt that you can obtain a patent on this device, and would advise that you get in touch with some reliable attorney.

CRUDE OIL BURNER.

(442) James M. Ryan, Kokomo, Ind., asks us for advice on a crude oil burner.

A. Altho the crude oil burner which you designed has several new features, there is nothing radically novel or new in the device as a whole, and we believe it will be rather difficult for you to secure a basic or even any form of patent upon such an idea. During each week the Patent Office passes thru one thousand patents and quite a large percentage of these are for crude oil burners. Very few of these ever see the light of day. We therefore hesitate to advise patent on this device.

DEMOUNTABLE RIM

(443) Armin Richard, Lafayette, Ind., submits a rather clever idea of a demountable auto-wheel rim, consisting of a series of transversely slotted bolts attached to the wheel, and openings in the rim adapted to receive said bolts so that when the rim is turned the bolts and rim are locked firmly in place. Three nuts serve to hold the rim in the locked position.

A. In the first place, a wheel on an auto is generally centered by the action of the screws and lugs, which lugs have a V shaped surface. For demountable rims some such system is absolutely essential. With your scheme this is impossible as it would be necessary to have a very snug-fitting wheel and rim in order to absolutely center the rim upon the wheel. Any appreciable difference in the size of the wheel and the size of the rim would make your scheme void.

In the second place, if the rim and the wheel, as we may assume, are fitted snugly and allowed to remain in place for a considerable length of time, dust and dirt would clog the device over the snug-fitting wheel, and could not be turned in order to release the tire except perhaps by a very large wrench. This necessitates an additional tool.

Thirdly. Many rims have been patented. Most of them will never see the light of day because the few types now employed are universally used. For these reasons we do not advise a patent on your device.

TELEPHONE MOUTHPIECE STERILIZER.

(444) H. F. Tatro, Franklin, N. H., submits a plan of a sterilizer for telephonic use consisting of a silk gauze screen adapted to fit over the mouth-piece of a telephone, which is kept saturated with a disinfecting solution.

A. We do not advise a patent for the following reasons: First, such screen as you intend placing upon a telephone always has a tendency to impair phone service, because the disinfectant comes in close contact with the transmitter and is blown into it, and secondly because it is a screen, which screen has always impaired service, as the telephone company can prove by extensive tests upon the same.

It is evident that such gauze would be a great dust retainer and make itself unsightly. The disinfectant idea will not be met with very favorably by either the public or the telephone officials.

PATENTS & TRADE-MARKS

SEND SKETCH AND DESCRIPTION for report on patentable nature, and instructions. Preliminary advice without charge. Full, prompt report in strict confidence. Reasonable terms, reliable service by Registered Patent Attorneys. **WRITE TODAY**

CLARENCE A. O'BRIEN & Co.

PATENT LAWYERS
1023 WOODWARD BLDG., WASHINGTON, D.C.

PATENTS

Hand Books on Patents, Trade Marks, etc., sent free. Our 74 years of experience, efficient service, and fair dealing, assure fullest value and protection to the applicant. The Scientist American should be read by all inventors.

MUNN & CO., 618 Woolworth Bldg., N. Y.
Tower Bldg. Chicago, Ill. 625 F St, Washington, D. C.
Hobart Bldg., 582 Market St., San Francisco, Cal.

PATENTS

If you have an invention and desire to secure a patent, send for our Free Guide Book. **HOW TO GET YOUR PATENT.** Tells our Terms, Methods, etc. Send model or sketch and description for our opinion of its patentable nature.

RANDOLPH & CO.
Dept. 172 Washington, D. C.

PATENTS

Thirty-five years experience. Send model or sketch for opinion as to patentability. Free "Inventors' Guide." Highest references and personal attention assure best results.

FRANKLIN H. HOUGH
520 Washington Loan & Trust Bldg.
Washington, D. C.

PATENTS

Write for free INVENTOR'S RECORD form for establishing the date of your invention, and INVENTOR'S BULLETIN Confidential Service

WM. H. MULLIGAN, PATENT LAWYER
110 Woodward Bldg. Washington, D. C.

INVENTORS

MODELS EXPERIMENTAL WORK

Are you looking for a reliable concern to assist you in developing that idea that you just can't work out? Consult us. With our staff of expert engineers and thoroughly equipped experimental machine shop, we can develop any proposition for you, mechanical or electrical, and make it work.

We develop, simplify and perfect inventions, make them commercially possible, and build working models. We design and build special automatic labor saving machinery. All business strictly confidential and protection guaranteed.

ELK MFG. CO., INC. 1926 Broadway, New York

PATENTS & TRADE-MARKS

FREE BOOKLET ON REQUEST—MY CLIENTS ARE INFORMED OF EVERY STEP TAKEN IN THE PROSECUTION OF THEIR CASES—

WARNER I. CUBBERLEY, PATENT ATTORNEY
22 NATIONAL CITY BLDG.
WASHINGTON, D. C.

PATENTS

C. L. PARKER Formerly Member Examining Corps. U. S. Patent Office. **PATENT LAWYER** McGill Bldg. Washington, D. C.

Patents, Trade Marks, Copyrights, Patent Litigation

Handbook for Inventors, "Protecting, Exploiting and Selling Inventions," sent upon request.

Free Book on PATENTS

Contains valuable information and advice to inventors on securing Patents. Send model or sketch of your invention for Free Opinion of its patentable nature. Prompt service. 20 years experience. Write today.

TALBERT & TALBERT 4287 TALBERT BLDG., Washington, D. C.

Printing Cheap

Cards, circulars, labels, book paper, Presses, etc. Larger \$5 Job press \$150. Save money. Print for others, big profit. All easy, rules sent. Write factory for press catalog, TYPE, cards, etc. **THE PRESS CO., D-47, Meriden, Conn.**

Electric Turn-table for Private Garages

(Continued from Page 42)

one wire being sufficient, the ground being employed as the *return* circuit. Connecting the two terminals of the circuit to two iron rods driven into the ground at G-1 and G-2, or to water-pipes eliminates the second wire.

On open-circuit systems such as that shown at D, the contact spring placed behind the door is of the *open-circuit type* and this particular type should be asked for when buying the same. A constant ringing attachment is almost always desirable in a burglar alarm of this type, and at Fig. E, the one used successfully by the writer for several years, is shown. Here an open circuit system is employed, using dry cells. If the spring contact is closed by opening the door of the garage, the four ohm relay, constructed from an old bell, attracts its armature and releases the weighted drop which falls on the two insulated contact springs, shown in further detail at Fig. 2-H. Once the bell starts ringing it continues to ring until its switch is opened or the springs separated by re-setting the relay drop.

A simple closed circuit system available for those having a 110 volt direct current circuit in their establishment for lighting and other purposes is shown at Fig. 2-F. Here a 150-ohm relay of standard telegraph pattern or else home-made, can be used with a 110-volt low wattage lamp connected in series. If the spring contact is released by opening the door or if the wire is cut, the relay armature will be released and the alarm bell circuit closed. A detailed diagram is shown also at Fig. 2-F for using a potentiometer resistance coil, so that if desired, the bell may be rung by current taken from the 110-volt D.C. line, thus eliminating all batteries. The voltage taken off in the bell circuit will be in direct proportion to the number of turns embraced in this circuit as compared to the total number of turns in the coil, i.e., if the coil contains 100 turns of resistance wire (usually wound over a layer of asbestos on a piece of iron pipe), then if the bell circuit includes say 10 turns, the voltage will be 1/10 of that passing thru the coil, or 11 volts, etc.

Fig. 2-G shows a balanced relay burglar alarm system. This is illustrated and described in *Modern Wiring Diagrams and Descriptions* by Horstmann and Tousley.

In the diagram C is a coil of any chosen resistance, which is to be placed inside the room or building to be protected. By tracing the circuits it will be seen that the current from battery B₂, which is a closed circuit battery, flows thru this coil and thru a closed circuit burglar alarm spring G, thence thru magnet R₁ back to the battery.

Another circuit running from the same battery goes thru magnets R₁₁ and M, back to the battery. When current is flowing from battery B₂, the armature E is held in a balanced position midway between R₁ and R₁₁ (this is facilitated by means of springs as shown), and the armature A is attracted. This holds the local bell circuit open. If the line running to C is opened, the current thru R₁ ceases, and it becomes demagnetized. The armature is then attracted by magnet R₁₁ and the bell circuit is closed at F. If the line running to C is short-circuited, the increased current in R₁ attracts the armature and the bell circuit is closed at F₁. If for any reason the battery B gives out



Bring Me A City!

Heeding no barrier of river, mountain, forest or desert; unmindful of distance; the telephone has spread its network of communication to the farthest outposts of our country.

The ranchman, a score of miles from his nearest neighbor, a hundred miles from the nearest town, may sit in the solitude of his prairie home and, at will, order the far-distant city brought to him. And the telephone obeys his command.

Time and space become of small account when, through desire or necessity, you would call across a continent.

This is what the "Long

Distance" service of the Bell telephone has accomplished for you; what science in construction has created; and what efficiency of workers has maintained.

You take the telephone as much for granted as you do the wonder of the changing seasons. You accept as a matter of course the company's ability to keep all the parts of this great nation in constant contact.

By so doing you offer a fine tribute to the Bell organization which has created this "Long Distance" service—a service no other country has attempted to equal.



AMERICAN TELEPHONE AND TELEGRAPH COMPANY
AND ASSOCIATED COMPANIES
One Policy One System Universal Service
And all directed toward Better Service



10c CHARGES YOUR BATTERY AT HOME WITH AN F-F BATTERY BOOSTER

Which is a Magnetic Rectifier for 105-125 Volt 60 Cycle Alternating Current. Leave battery right in the car. Snap clips of Charger on battery terminals. The Meter shows you just the amount of current flowing. No skill required to operate. Everything complete in one compact unit, ready to use. Automatic and fool-proof. Carbon electrodes rectify the current and last for thousands of hours.

Bantam Type 6-6 amp. 6 v. battery \$15 Bantam Type 12-5 amp. 12 v. battery \$15
Type 16-8 amperes for 6 v. battery 24 Type 112-6 amperes for 12 v. battery 24
Type 166-12 amperes for 6 v. battery 32 Type 1612-7 amperes for 12 v. battery 32
Type 1626-12 or 7 amperes in combination for both 6 and 12 volt batteries. . . . 48

The larger type are recommended for the heavier batteries or where time is limited. Shipping weight complete with Ammeter and Battery Clips, 11 to 15 pounds. Order from your dealer or send check for prompt Express shipment; include postage and insurance charges for Parcel Post Shipment or tell us to forward C.O.D. Also other F-F charging apparatus that operate on Farm Lighting Plants and Direct Current Circuits. If not ready to order now write today for descriptive Bulletin No. 12.

F-F ROTARY RECTIFIER FOR GROUP CHARGING
Real Economy in first cost and in service. Charges up to 36 cells. Full Wave, Automatic, Dependable. Bulletin 12-A gives full information. Write today.

The France Manufacturing Co., Cleveland, Ohio, U. S. A. General Offices & works:

YOUR TROUBLES ARE OVER

THIS DOES IT



CHAMPION TRANSFORMERS

Decrease gasoline consumption—give greater power—reduce carbon deposits. They can be attached in a few minutes and from that time you will have a sweet, smoothly running motor which starts easily even in zero weather.

YOUR MOTOR PUMPS OIL? DON'T WORRY!

The intense, hot blaze at your plug due to the Transformer, explodes every particle of oil and gas, giving greater power, and leaving no carbon.

DON'T BE FOOLED BY REPAIRMEN who tell you that the transformer is not practical. **THE CHAMPION**

TRANSFORMER is not only practical, but it is the only oxygen burning system of ignition on the market. Burn more oxygen and less gas!

THE CHAMPION TRANSFORMER IS A PERFECTED ARTICLE

—the result of fourteen years' ignition experience. It is sold on a money-back guarantee, which comes with every set. The special gauze covering over electrodes is a patented fire-proof feature. Champion Transformers are suitable for any engine that uses a spark plug.

For Tractors, Motorcycles, Pleasure Cars, Gas Engines

SEND NO MONEY

Write us today and give us your name and address; also the kind of car you drive. We will send you a set of Champion Transformers by parcel post. Pay the postman \$1.50 for a four-cylinder set or \$2.00 for a six-cylinder set and the Transformers are yours. You also get a free booklet written by ignition experts which alone will save your usual Spring repair bills.

VAN KERR CO., Dept. AT, 139 N. Clark St., Chicago
Over 100,000 satisfied customers are using Champion Transformers

Attach them yourself. All you need is two minutes and a pair of pliers.

Proudfoot Radio Specials

TUNING TRANSFORMER—RANGE 140-3500 METERS

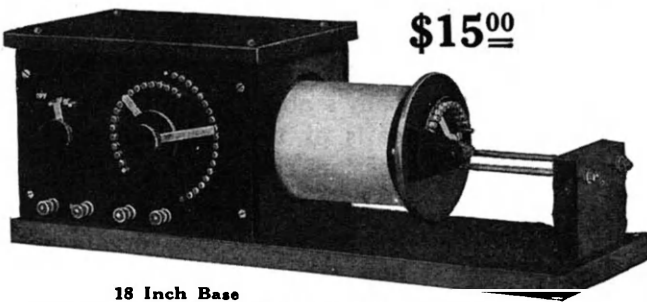

\$15⁰⁰

DESIGNED FOR MOST SENSITIVE ADJUSTMENT POSSIBLE METAL NICKEL WINDING GREEN SILK MAHOGANY FINISH

18 Inch Base

- 1—Vacuum Detector Cabinet, 7½"x5¼".....\$12.50
- 2—Amplifier Cabinet, 7½"x5¼"..... 18.00
- 3—Detector and One-Stage Amplifier, 7½"x6½"..... 25.00
- 4—Detector and Two-Stage Amplifier, 7½"x9"..... 35.00
- 5—Regenerative Set, 7½"x14"..... 35.00
- 6—Regenerative Set with Detector and One-Stage Amplifier, 7½"x18"..... 45.00

SPECIAL OFFER—Amplifier cabinet with any other purchase..... 13.00
You can add as many stages of amplification as you desire. Special design transformer so that 5 stages of amplification can be added. **NO HOWLING.**

THESE INSTRUMENTS HAVE—Panels of ¼" bakelite; boxes with waxed oak finish, hinged covers, no ugly hooks, special spring ball clasp; black oxidized binding posts; fixed condenser in grid circuit; VT sockets highly polished lacquered brass, parts all machined. All INSTRUMENTS 5" in depth. Have standard nickel jacks. **PLUG** with each instrument ordered.

ALL INSTRUMENTS ABSOLUTELY GUARANTEED

G. M. PROUDFOOT, 361 E. Ohio St., Chicago, Ill.



ACHROMATIC TELESCOPE MADE UPON NEW SCIENTIFIC PRINCIPLES.

Positively such a good Telescope was never sold for this price before. Eastern Telescopes are made by one of the largest manufacturers of telescopes in America; we control entire production: measure closed 8 inches and open over 2½ feet in 4 sections. They are nicely brass bound, with scientifically ground lenses. Guaranteed by the maker. Every sojourner in the country or at the seaside resorts should certainly secure one of these instruments, and no farmer should be without one. The scenery just now is beautiful. A Telescope will aid you in taking views. Objects are brought to view with astonishing clearness. Sent by mail or express, safely packed, prepaid, for only 99 cents. Our new Catalogue of Watches, etc., sent with each order. This is a grand offer and you should not miss it. We warrant each telescope just as represented or money refunded, Send 99 cents today. To dealers 6 for Four Dollars.

EASTERN NOVELTY CO., DEPT. 67, 172 E. 93d STREET, NEW YORK.

the magnet M is demagnetized and the armature A closes the bell circuit. When the alarm is not in use, the switch S is thrown over, opening the alarm circuit.

Fig. 2-H shows the details of the continuous ringing relay drop described in connection with the diagram illustrated at Fig. 2-E. It is self-explanatory and it need only be mentioned that several different forms of contacts may be provided, such as having one of the contacts fastened on to the drop so that it will fall into a little cup containing mercury, and thus close the circuit; or two spark coil vibrator springs, having platinum, silver or tungsten contacts, can be used as shown.

The diagram, Fig. 2-I, shows the best way to install any burglar alarm wiring, particularly when an open circuit system is used, which will fail to give a signal in the event that the wires are cut. Standard rubber-covered wires, such as used for electric lighting, are run thru iron pipes, preferably the standard enameled wiring conduit. In some cases, lead covered cable is used, containing one wire if a ground return is to be used, or two wires if a full metallic (ungrounded) circuit is to be employed.

Bombing Planes Versus Battleships

(Continued from page 19)

than that in which the dreadnaught can be built. At this point it is interesting to consider for a moment a somewhat different phase of this airplane-versus-battleship controversy, as it is not by any means the explosive bomb and its consequent destructive effects alone that constitute the reason for the apparent superiority of the bombing plane, but the chances are, that by means of poisonous gas bombs, particularly those filled with the latest gas or volatile liquid poison produced by the U. S. Chemical Warfare Service, the whole crew of 900 to 1200 men on the mightiest war-ship afloat, can be "snuffed out" or seriously incapacitated, in a very short time if along with the destructive high explosive bombs, the bombing planes keep dropping a number of bombs delivering poisonous gas or liquids.

The poison gas spreads thruout the compartments of the ship very quickly and the steel cut-off walls of the cabins and compartments would be of practically no value in actual battle attack by such an aerial bombing squadron, as these walls would soon be battered severely and holes would be blasted thru them by the exploding TNT or other high explosive bombs.

One of the claims of the naval experts who have in a sense scoffed at the claims and actual demonstrations by the army aerial bombing experts, has been that aerial bombs have never yet succeeded in puncturing the hull of a warship and sinking it. This argument can be answered in two ways on the score of the flying men, viz: if the bombing attack includes both explosive destructive bombs as well as the poisonous gas or liquid types, it does not make any difference whether the ship is sunk or not, for it will certainly be incapacitated in a few minutes; and the second answer lies in the fact that successive bombing would almost certainly damage the superstructure and deck armor to such an extent that eventually some of the bombs, possibly after the second or third attack, would pass into the lower regions of the hull, and exploding, would damage the underwater hull armor and cause the sea water to enter and sink the ship.

(Continued on page 82)

LEARN WIRELESS At Home By Mail



WIRELESS Operators Wanted at Once—For Merchant Marine, Commercial Land Radio Service, Radio Supply Factories, U. S. Navy Government Service and Aerial Mail. National Radio Institute experts will teach you Wireless at your home by mail, through fascinating course of copyrighted lessons and our famous Automatic Natrometer. Read About This Splendid Opportunity for the Young Men of America.

Salaries up to \$6,000

At the very start our graduates are paid \$125 a month which with their allowance for room and board is the equivalent of about \$200 a month. Promotion is sure and steady for the well-trained Wireless man. One of our graduates has risen to \$6,000 a year. Positions and pay are as follows: Supercargo and Wireless Operator—\$175 a month; Radio Mechanic—\$1,500 to \$2,000 a year; Radio Aid—\$6 to \$8 a day; Radio Inspector—\$1,500 to \$3,000 a year; Radio Engineer—\$6,000 a year up; Radio Draftsman—\$7 to \$10 a day.

Travel Without Expense

As a Wireless Operator you can travel, visit foreign countries, increase your knowledge of world affairs while drawing excellent pay. On shipboard you are rated as an officer with fine living quarters. If you do not care to travel, there are positions nearer home at Land Radio Stations and Offices.

Experts of Nation's Capital Teach You Wireless at Home

The National Radio Institute is headed by experts of the Nation's Capital who have been closely allied with government training of men for wireless positions. Instruction of students is under direction of Jas. E. Smith, former director of Radio Dept. Howard University, and E. R. Haas, formerly of the Radio Division of Yale University. These experts, assisted by a large staff of well-known Radio men, will teach you Wireless by mail, in your home, quickly and easily, in a fascinating practical way, just as they have already taught hundreds of students throughout the world.

Remarkable Automatic Wireless Instrument FREE

In addition to all necessary text books, including a full set of our up-to-date, copyrighted Lesson Pamphlets, for home study, we present FREE to each student, while taking the course, our remarkable Automatic Wireless Instrument—The Natrometer. It transmits messages in 600 different combinations just as though coming from thousands of miles away. It can be regulated to any speed from 1 to 30 words a minute, works automatically without use of aerials, and comes to you complete with phones, etc., in a neat carrying case. Teaches you practical Wireless at home in a simple though scientific way. It is yours to keep upon completion of the course.

Pay as You Learn

A small first payment will start these practical lessons on their way to you. You pay as you learn. Many of our students secure wireless positions before completing the course.

Oldest and Largest Correspondence School of Wireless in America

The National Radio Institute, established in 1914, is today the oldest and largest Wireless School in America teaching Wireless by mail. Our graduates are making good all over the world. We are fully recognized by the U. S. Department of Commerce which allows our graduates five to ten points credit when taking First Grade Government License examinations. The National Radio Institute heads the printed list of Wireless Schools recommended by the U. S. Shipping Board.

Special Free Offer

Students who enroll promptly receive in addition to our complete course in Wireless Telegraphy, a complete Special Course in Wireless Telephony, and if you wish, a one month Post Graduate Course at our big Washington School. These special privileges are free only to N. R. I. Home Study Students.

NATIONAL RADIO INSTITUTE
Dept. 571
WASHINGTON, D. C.

FREE

Write Today for FREE BOOK
Send the following coupon,
or a post card today for a
copy of our interesting book
"Wireless. The Opportunity of Today."

MAIL THIS COUPON TODAY

National Radio Institute,
Dept. 571, Washington, D. C.
Send me your FREE book, "Wireless the Opportunity of Today." Tell me about your Home Study Course in Wireless Telegraphy and Telephony—and free post-graduate course—and your Special Instrument offer.
Name
Age Occupation
Address
City State



Professionals as well as Amateurs

The "Superior" type headset was originally designed for amateur use. As such it has been used by tens of thousands of wireless enthusiasts. But so skillfully had this headset been designed, from the standpoints of both efficiency and durability, that it soon was adopted by commercial wireless companies and issued by them to their operators.

"Superior"
2,000 ohms, D.C., weight 14 oz.,
complete with head band and polarity
indicating cord. Price, \$8.00.



BRANDES MATCHED-TONE HEADSETS 100% Receiver Satisfaction

Both telephones so perfectly matched that they emit exactly the same tone; catching the faintest signals in one clean, clear note. This feature is found in Brandes Headsets only.

Brandes Headsets will last for years. We know of "Superior" Headsets, bought in 1910, still in use and giving the same good service as when new.

TRIAL OFFER

Send \$8 for a "Superior Headset." Try it for 10 days. If you don't find it the best headset regardless of price you ever tried and are not entirely satisfied with it, send it back and your money will be refunded promptly.

C. BRANDES, Inc.
Room 814, 32 Union Sq., New York
Pacific Coast Distributors

LEO J. MEYBERG CO.
428 Market St., San Francisco, Cal.
Also Makers of

Navy Type Headsets, 50,000 ohms, A.C. \$14.
Trans-Atlantic Headsets, 25,000 ohms, A.C., \$12.

Send 5c for Catalog "F."

Dealers: Write for our special proposition to you.

Bombing Planes versus Battleships

(Continued from page 80)

Another important phase of the aircraft-versus-the-navy-ship battle and which undoubtedly the reader has been thinking of all along, is that even with the present arrangements, the navies of practically all the leading powers have provided Motherships for aircraft, either of the land or seaplane type, and it is also quite generally known that the largest ships, such as cruisers and dreadnaughts, are now equip with one and in some cases several armed seaplanes. When this point was brought up in the recent discussion at Washington that the navy would not only attack such bombing planes in actual battle with anti-aircraft guns, but that they would also have the added protection of their seaplanes (which would counter-attack the bombers) the army bombing plane experts practically laughed at these facts. They stated as we have already mentioned, that they were not the least afraid of anti-aircraft gun-fire in the first place—and secondly, they were certainly much less afraid of any counter-attack by the seaplanes carried upon warships at the present time, for the reason that the seaplane, owing to at least its present design, cannot fly much faster than 100 miles an hour and in many cases a much lower speed only is attainable, while the modern bombing planes of the latest type, can make a far greater speed than this. Furthermore, a bombing squadron made up of say five large planes loaded with bombs, would be accompanied invariably by a flock of high speed scout or combat planes. The army knows what they are talking about, for with their standard plane of average power they can reel off 150 miles an hour, easily, and with their specially high-powered planes such as the Verville-Packard type, they have actually attained a speed of 175 miles an hour or more.

Another argument put up by the naval experts was that in the recent bombing test on the old battleship *Indiana*, the ship was stationary and therefore the target was extremely easy to hit, whereas under actual battle conditions (under which the ex-Secretary of the Navy, Hon. Josephus Daniels, stated that he would be willing to take his chances on a dreadnaught) the ships would not stand still and thus provide such an easy target for the flying bombers.

It was quite surprising to hear the counter-testimony by the army experts, who firmly believe in the undoubted supremacy of the *air wing*, and whose final argument was that as a matter of actual fact, it is easier to bomb accurately and hit a moving target, such as a dreadnaught tearing thru the seas at even 28 to 30 knots an hour, than it is to hit a stationary target. So far as has been learned, very little if anything has been done on the part of the navy experts, that is in a radical way, to circumvent the menace of the aerial bombing squadron of tomorrow, which presents a serious problem that should at once be attacked by the best naval experts our country has at its command.

As we go to press a report comes from Washington that in June, General Mitchell will attempt to incapacitate a battleship with crew aboard, simply by bombing it with the newest poison gas bombs.

The old saying still holds true, and was never more completely applicable than now, we believe, "An ounce of prevention is worth a pound of cure."

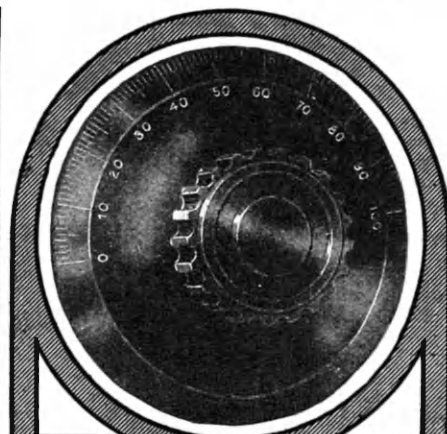

CORWIN DIALS

The distinction Corwin Dials impart to a radio station is only exceeded by their accuracy and ease of operation. Prices are as low as economical production and efficient marketing will permit, with due regard for quality. *Outside of that*, there isn't any particular reason for specifying Corwin Dials.

3" Dial, 75c; with knob, \$1.30
3 7/8" Dial, \$1.00; with knob, \$1.70

At all Radisco Agencies,
and other reliable dealers
or sent postpaid anywhere.

A. H. CORWIN & CO.
4 West Park St., Newark, N. J.

ACE E THAT DOLLAR

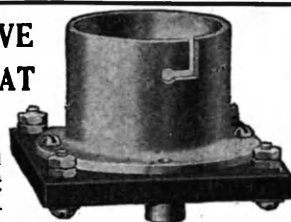

you intend spending for a grid leak. Buy the "Ace" Vacuum Tube Socket complete with Grid Leak mounted on base.

Ace V. T. Socket with grid leak . . . \$1.50
Ace V. T. 4 tube socket mounting for C. W. Units 6.00
Ace V. T. Die Casting only without base55

Specify whether panel or table type is desired. If your dealer cannot supply you order direct from us. Dealers solicited. Mail orders given prompt attention.

Send 3 cents in stamps for SPECIAL PRICE BULLETIN NO. 102.

THE PRECISION EQUIPMENT CO.

Mfrs. & Distrs. of Radio Equipment

Dept. E., 2437-2439 Gilbert Ave., Cincinnati, Ohio
"You May Pay More But You Can't Buy Better"
Member A.R.R.L. Radio Call "8xB"



RADIO EQUIPMENT

Our catalog No. 22 illustrates everything in wireless. Send 10 cents in stamps for it.

F. D. PITTS CO.

Boston, Mass.

12 Park Square Dept. D

WIRELESS CATALOG

JUST OUT 10c in stamps or coin, brings new loose-leaf wireless catalog; places you on mailing list to receive bulletins sent out regularly. Bulletins fit catalog and keep you posted on latest developments in wireless telegraph and telephone, give hook-ups, illustrations and prices on latest MAGECO apparatus. Get your name on our mailing list NOW. The Marshall-Gerken Co., Dept. 105, Radio Bldg., Toledo, Ohio

RADIOTRONS

“A TUBE FOR EVERY NEED”

Radiotrons are now recognized as the amateur's and experimenter's standard for Radio detection, amplification and power work. They are available at established Radio dealers throughout the United States.

Scientifically designed and manufactured in the country's largest lamp factories, Radiotrons come to the experimenter with uniform and dependable characteristics.

One of the following tubes is certain to meet your requirements

**U. V. 200
DETECTOR
\$5.00**

**U. V. 201
AMPLIFIER
\$6.50**

**U. V. 202
POWER TUBE
5-Watt
\$8.00**

**U. V. 203
POWER TUBE
50-Watt
\$30.00**

**U. V. 204
POWER TUBE
250-Watt
\$110.00**

The Radio Corporation's tubes are covered by patents dated November 7th, 1905, January 15th, 1907, and February 18th, 1908, as well as by other patents issued and pending. Tubes licensed for amateur and experimental use only. Any other use will constitute an infringement.

Your dealer has Illustrated Bulletins on Radiotrons,
or write direct to

SALES DIVISION, COMMERCIAL DEPARTMENT,
SUITE 1805

**RADIO CORPORATION OF AMERICA
233 BROADWAY
NEW YORK CITY**

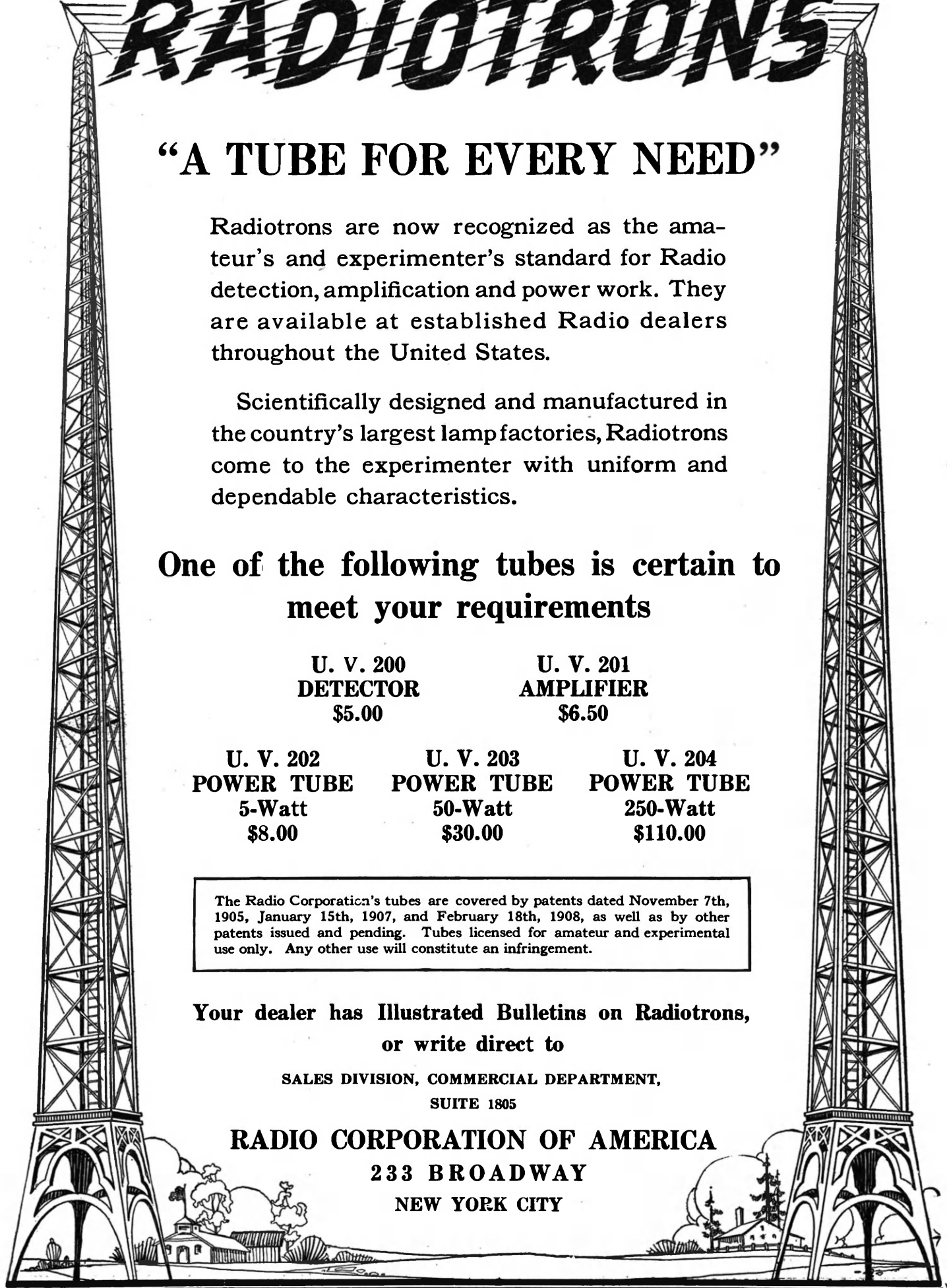

Compact Audion Control Unit

(Continued from page 50)

filament control by both amateur and the commercial companies. Its resistance unit consists of a special wire so wound on an insulating core that it cannot become short-circuited. Neither will the turns loosen with use. The spring lever making contact with the resistance is remarkably smooth running. Resistance of the unit is 6 ohms, current carrying capacity 1.5 amperes.

The Grid Leak is of the "pencil mark" type and can be easily varied to suit the characteristics of the tube, it being necessary to provide a resistance of sufficiently low resistance to enable excessive grid charges to leak off and thereby prevent paralization of the tube.

Nine Binding Posts are provided, two for the telephone receivers, two for the "A" battery, two for the "B" battery, and three for the timer. Arrangement is made so that connection to the grid can be established either directly or thru the mica grid condenser. All connections are brass punchings, insuring low resistance and perfect contact.

The Panel itself is moulded *condensite*, a material of the highest insulating qualities and great mechanical strength. It is heat proof and possesses a durable, glossy black finish. All metal fittings are brass, nickel plated. The unit may be used in a horizontal position on the table or mounted vertically as a panel. It measures 5 by 3 1/4 by 1 3/4 inches.

A Decremeter for the Amateur

(Continued from page 50)

tion where it is concentrated in a narrow band. With this decremeter, it is possible to picture to yourself graphically just how the energy is distributed and to really adjust your transmitter for the most efficient results.

Specifications—The decremeter is furnished in a mahogany finished case with a Bakelite panel. All metal parts are nickel plated. Complete operating instructions and calibration are furnished. Wave Length scale: Direct reading. Range: Present and contemplated Amateur Wave Lengths. Dimensions: 7"x5"x6". Weight about 3 lbs.

Electric Weather Forecasting for Amateurs

(Continued from page 43)

the voltage generated in the coils, a scale can be made, where each volt will equal so many miles per hour. A better way is to graduate a scale from a standard instrument.

Fig. 4 shows the circuit by which all are utilized. For their connection the wires 1, 2, 3, 4 and 5 are necessary from the location of the instruments to the registering apparatus.

The resistance of the sections AC and AB must be equal, and also DE and DF, as the Wheatstone bridge method is used. This may be accomplished by the use of a smaller wire in the shorter circuits, or by adding resistance wire until they are equal.

By using the switch S one bridge is made use of. The two sections of the arm are insulated.

By placing these instruments in an efficient place subject to wind and rainfall, and by making them weatherproof by shellacking the coils, etc., efficient results may be had.

LEARN WIRELESS AT HOME

The Demand for Good Wireless Operators far Exceeds the Supply

The New York Wireless Institute will make you an operator—AT HOME—in your spare time—quickly, easily and thoroughly. No previous training or experience required. Our Home Study Course has been prepared by Mr. L. R. Krumm, formerly Chief Radio Inspector, Bureau of Navigation, N. Y. He resigned last August to accept a position of still greater responsibility with one of the largest Commercial Radio Corporations in the United States. Radio experts able to impart their practical and technical knowledge to YOU in an easy to understand way will direct your entire Course. The graded lessons mailed you will prove so fascinating that you will be eager for the next one. The instruments furnished free will make it as easy to learn the Code as it was to learn to talk. All you will have to do is to listen.

Big Salaries

Wireless operators receive excellent salaries ranging from \$125 to \$200 a month and it is only a stepping stone to better positions. There is practically no limit to your earning power. Men who but yesterday were Wireless Operators are now holding positions as Radio Engineers, Radio Inspectors, Radio Salesmen at salaries up to \$5000 a year.

Travel the World Over

A Wireless Operator can visit all parts of the world and receive fine pay and maintenance at the same time. Do you prefer a steady position without travel? There are many opportunities at the numerous land stations or with the Commercial Wireless or with the Steamship Companies.

FREE Instruments and Text Books

We furnish free to all students, during the Course, the wonderful receiving and sending set exactly as shown in the illustration. This set is not loaned, but given to all students completing the Course. One coil of dry battery all that is required. No additional wiring, aerials, etc., needed.

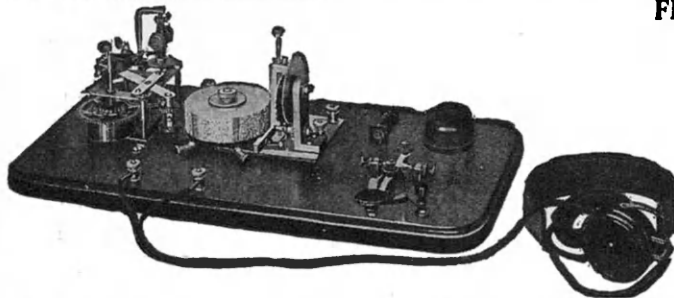

This wonderful Set for learning the Code furnished free with our Course.

The Transmitter shown is the celebrated Omnigraph used by several Departments of the U. S. Government and by the leading Universities, Colleges, Technical and Telegraph Schools throughout the U. S. and Canada. Start the Omnigraph, place the phone to your ear and this remarkable invention will send you Wireless Messages, the same as though you were receiving them through the air, from a Wireless Station hundreds of miles away. When you apply for your license, the U. S. Government will test you with the Omnigraph—the same model Omnigraph as we furnish to our students. Ask any U. S. Radio Inspector to verify this.

Wireless Telephony Course

We have incorporated in our Institute an up-to-date and complete Course in Wireless Telephony, written by our Chief Instructor, Mr. L. R. Krumm. This Course is also furnished free.

AMERICA'S FASTEST GROWING WIRELESS INSTITUTE

Send for FREE Booklet

Without obligating you in any way, send for our booklet "How to Become an Expert Wireless Operator"—it is free. Mail the coupon below, or postal or letter—but do it today.

NEW YORK WIRELESS INSTITUTE,
Dept. 213, 258 Broadway, N. Y. City.

NEW YORK WIRELESS INSTITUTE
Dept. 213, 258 Broadway New York City
Send me, free of charge, your booklet "How to Become an Expert Wireless Operator", containing full particulars of your Course, including your Free Instrument offer.

Name.....
Address.....
City or Town.....State.....

FREE Post-Graduate Course

A one month's Post-Graduate Course. If you so desire at one of the largest Wireless Schools in New York City. New York—the Wonder City—the largest port in the World and the Headquarters of every leading Wireless and Steamship Company.

The Department of Commerce of the U. S. Government

recognizing the value of the instruction furnished by us, allows all of our graduates a five-point credit in their examination for first-grade license. THE U. S. SHIPPING BOARD will also testify as to the value of this instruction.

Easy Payments

A small payment down will enroll you. We will make the payments so easy that anyone ambitious to enter the fastest growing profession—Wireless—may do so.

There Must Be a Good Reason.

There Is—

- The Best Course in Theory available.
- The Best Instruments obtainable.
- The Best Text Books and Diagrams on the market.



\$100.00 EARNED BY YOUNG ARTIST IN 2 DAYS

Conscientious, careful training by members of our Faculty made this possible. You, too, should succeed.

Earn \$50, \$75, \$100 a week and more

The business world pays big prices for good designs and illustrations. Learn to draw during your spare time by the "Federal" home-study method—endorsed by high authorities. EASY TO LEARN, EASY TO APPLY. Send 6c in stamps today for "Your Future," a beautiful new 66-page book which explains every step. State age and occupation. Federal School of Commercial Designing, 529 Federal Schools Bldg., Minneapolis, Minn.



New Invention—Radio Apparatus

Write for Literature—it's FREE
Mignon System Mfg. Co.
Buffalo, N. Y., U. S. A.



ANNOUNCEMENT



Made Right

Mr. Manufacturer Mr. Jobber Mr. Amateur

Stay Tight

DID YOU SEE THE LEADER BINDING POST AT THE NEW YORK RADIO CONVENTION? IF NOT, A GLANCE AT THE ACCOMPANYING CUTS (actual size) WILL ACQUAINT YOU WITH THESE UNIQUE POSTS

These novel patented Posts were not only **Real Winners** but were one of the surprises of the Convention.

This line of unique Posts appeals to the trade **BECAUSE!**

There are no parts to become lost.
They will not mar the finest of wires.
They are easily mounted on standard equipment
They are built for a 24-hour service.

They permit a smaller sized Post to be used.
Extreme vibration will not loosen their lock grip.
They are surprisingly low in price.
They harmonize with other moving parts.

THEIR PARALLEL CONTACT SURFACES EXTEND THE FULL WIDTH OF THE POST

The cuts, which are actual size, illustrate a few sizes of the plain Post and one size of the insulated Post opened and closed.

The Base of the plain Post is knurled which prevents turning and is tapped to take a 6, 8, or 10-32 machine screws. We also supply them with a standard machine screw, wood screw or threaded stud of various lengths and with nuts and washers.

The insulated Post at present is being made in two sizes with threaded studs 8, 10 or 1/4-32 thread and in suitable lengths.

We can supply either style Post in any finish desired but unless otherwise ordered they will be furnished in a plain screw machine finish of first class quality.

Our modern equipment and facilities also enables us to quote unusually low prices on furnishing contacts, nuts, washers, standard machine screws, inserts and other accurately made screw machine products.

Pamphlets describing both of these unique Posts giving price lists are now ready for distribution and our attractive discounts in quantities will appeal to manufacturers and jobbers.



Buddy



Sergeant

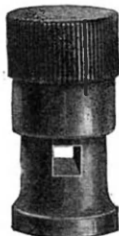

Captain



Opened



Closed

IMPORTANT NOTICE TO AMATEURS

Do not accept inferior binding posts. Demand the "Leader"—specify that it be used on the sets you order from your dealer. Or you can buy "Leader Binding Posts" yourself from any leading radio house. Ask for them. Do *not* order from us. Your dealer can supply you if you insist.

THE H. H. EBY MANUFACTURING CO.

1302 Wallace Street

Philadelphia, Pa.

Never in the History of Radio Were These Prices Approached

Improved Navy Type Receiving Transformer again reduced from \$27.50 to the startling price of **\$16.95**

Improved Arlington Receiving Transformer again reduced from \$15.00 to the startling price of **\$7.75**

Substantial reductions on many other radio instruments in our catalog No. 14. Circular with reduced prices and a large number of new instruments mailed on request.

Mail 12c in stamps or coin (not sent otherwise).

"The Greatest Radio Catalog in the World"

The Universal Verdict of Tens of Thousands of Radio Amateurs.

Duck's No. 15 Big 225 Page Wireless Catalog Just Out.

A Veritable Treasure House of Everything Worth While and Dependable in Radio. The largest, most comprehensive, artistic and educational wireless catalog published. The Beacon Light to guide you right in the selection of your radio purchases, and at prices that will command your attention. Every instrument guaranteed with privilege of return if not satisfied.

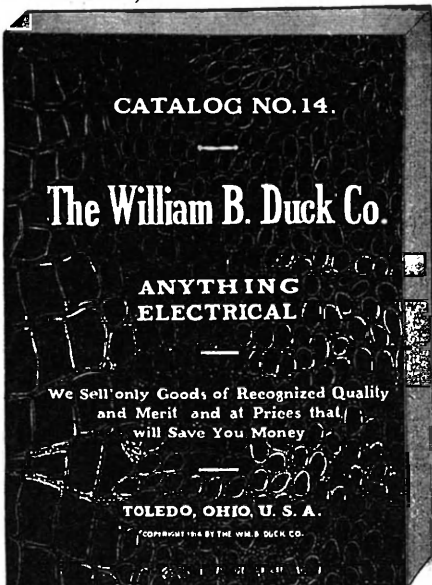

OTHER SUBSTANTIAL REDUCTIONS ON ITEMS IN CATALOG NO. 14

- No. R40 Receiving Set..... **\$22.50**
- No. R41 Receiving Set..... **38.50**
- No. R41a Receiving Set..... **28.50**

THORDARSON TRANSFORMERS

- 1 K. W. Type R..... **\$40.00**
- 1/2 K. W. Type R..... **28.00**
- 1/2 K. W. Type R..... **22.00**
- 1 K. W. Type RS..... **30.00**
- 1/2 K. W. Type RS..... **20.00**
- 1/2 K. W. Type RS..... **15.00**
- No. A1792 Thord. Condenser..... **25.00**
- Nos. 50-51, 52 Switch Contacts, each... **.03**
- No. 1023 Mica Condenser..... **.60**
- No. B670 Det..... **2.75**
- No. A862 Det..... **2.75**
- No. A1915 Det..... **1.50**
- No. A367 Murdock Condenser..... **4.50**
- No. A1002 Receiving Set..... **9.75**
- No. A1916 Condenser..... **1.65**
- No. 61x08A Tuning Coil..... **2.95**

- No. 61x10 Tuning Coil..... **\$4.95**
- No. 14 Aluminum Wire per lb..... **.90**
- All Binding Posts Reduced..... **33 1/2%**

ONLY A FEW OF THE MANY NEW RADIO INSTRUMENTS IN CATALOG NO. 15

- Type C-300 Cunningham Bulb..... **\$5.00**
- Type C-301..... **6.50**
- "UV" 200 Radiotron Bulb..... **5.00**
- "UV" 201..... **6.50**
- Type C-302 5-Watt Cunningham Power Tube..... **8.00**
- Type "UV"-202 5-Watt Radiotron Power Tube..... **8.00**
- Type C-303 50-Watt Cunningham Power Tube..... **30.00**
- No. A200 Control Panel..... **7.50**
- A complete line of new detector regenerative and amplifying sets
- Connecticut Variable Condenser..... **6.50**
- Turney Spider-Web Unit..... **6.00**
- All the new Murdock Panel Type Variable Condensers.....
- Burgess "B" Batteries.

Send 12c for Our Big Catalog Today

THE WILLIAM B. DUCK COMPANY, 230-232 Superior Street, TOLEDO, OHIO

Let CONTINENTAL

fill all your radio needs—wherever you live—from their wonderfully complete stocks, by mail, with

ACCURACY : SPEED : COURTESY

Order direct from this ad. Send your remittance, by bank draft or P. O. Money Order. Your goods will be shipped the day we receive the order.

MAY SPECIALS

PARAGON-RADIOTRON COMBINATION.

A complete VT control unit—equipped with grid condenser, grid leak, tube socket, rheostat and a Radiotron UV 202. Includes everything needed for an efficient VT unit—all for \$11.00 postpaid. If you haven't a VT detector, start in now with one of these complete units.

RADIOTRON UV 202
The new 5-watt transmitting tube
Price \$8.00. Postage 10c.

PARAGON R. A. TEN
Amplifying Short Wave. Regenerative Receivers.
Guaranteed for two Years
Price Eighty-Five Dollars.

VARIOMETERS

Radio Craft.....	\$6.00
Nightingale (small).....	4.50
Nightingale (large).....	5.50
Grebe.....	8.50
Clapp Eastham.....	5.75
Clapp Eastham (with knob and dial).....	6.50

COIL MOUNTINGS

LC 100-7.....	10.00
LC 101-7.....	13.00
LC 201-7.....	15.00

DUBILIER CONDENSERS

D 100-23 1/2 KW 10000 volts, .007 MFD.....	19.00
D 101-23 1/2 KW 14000 volts, .007 MFD.....	30.00
D 102-23 1 KW 21000 volts, .007 MFD.....	45.00
D 103-23 1 KW 25000 volts, .007 MFD.....	50.00
D 113-23 1 KW 25000 volts, .01 MFD.....	55.00
Murdock, per section, 483, 8 transmitting condensers.....	8.25
Murdock, per section, 488, 8 transmitting condensers.....	5.00

SPARK COILS

7758 1/4 inch.....	4.50
7759 3/8 inch.....	5.50
7760 1/2 inch.....	7.50
7761 1 inch.....	8.25
7762 1 1/4 inch.....	11.00
7763 2 inch.....	15.00

INSULATORS

6222-50 Lead-in Insulator (Commercial size)....	5.00
6858-50 Lead-in Insulator.....	4.60
6815-50 Lead-in Insulator.....	2.50
6268-50 Lead-in Insulator.....	1.70
4507-50 10 inch, commercial.....	1.00
4502-50 5 inch.....	.60
4507-50 Ball Insulator.....	.50

Our 112-page catalogue, containing tables for quickly figuring all radio calculations, the conventional signals and abbreviations, etc., mailed anywhere in the world for 25 cents.

CONTINENTAL RADIO & ELECTRIC CORP.

J. DiBlasi, Sec. J. Stantley, Treas.
Dept. A14 6 Warren St. New York

NEW MOTOR BARGAIN

GENERAL ELECTRIC

1 HP Motor
110 V
A. C. 60 cycle
single phase,
1750 Speed.
Complete with
Cord, Plug and Grooved Pulley.

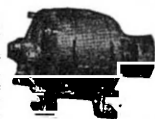

Will operate \$21.00 Washing Machines, Sewing Machines, Lathes, Grinders, Bottle Washers, Etc. Satisfaction guaranteed or money refunded.

Illustrated catalog of motors and supplies FREE

HYRE ELECTRIC CO.

631 K. South Dearborn Street Chicago, Ill.

TELEGRAPHY

(Both Morse and Wireless) and RAILWAY ACCOUNTING taught thoroughly and quickly. Big salaries now paid. Great opportunities for advancement. Oldest and largest school; established 46 years. Endorsed by Telegraph, Railway, Radio, and Government officials. Expenses low—opportunities to earn large portion. Catalog free.

BODGE'S INSTITUTE

A Street, Valparaiso, Ind.

What to Invent

By JAY G. HOBSON

(Continued from page 52)

efficient as far as they go, but they don't go far enough. The other day I was riding along the street with a friend who happened to remember the need of more gas, so we pulled into one of these regular supply stations, with an important young attendant keeping watch, and honked our honker until I began to think it wouldn't ever be able to honk again, but no "gas-boy" came to our klaxon-bidding. After waiting for several hours (it seemed) the young attendant appeared from his cubby-hole, inquiring if we wanted something. Of course we could have been paying him a social call, but any observing individual could have seen how empty our buss was, by the fact that we didn't have gas enough to get all the way into the station before old-faithful chugged her last breath and died.

We pointed to the tank in disgust, telling the gas-giver the amount desired. After fumbling around with several levers, the young fellow connected the hose to our tank and began to grind out the liquid gold. After a little longer he completed the operation by extracting a goodly sum from my companion for the liquid. Continuing on our way I asked him how he knew that he received what he paid for, and he frankly admitted he did not know, that the attendants could very easily set the measures at a scant quantity and the motorist would never be the wiser. This condition set me to thinking and the idea of an automatic filling station appeared.

A filling station with the gas stored overhead in a large tank with concrete base and super structure. With a drive-way underneath, so that motorists could drive under the supply, deposit the proper amount in the slot, place the hose in the automobile tank and receive an exact measure of gas without waiting for an absent attendant, or the uncertainties of the proper amount paid for. Gasoline companies would effect a large saving in the wages of a clerk who would no longer be necessary with an automatic station as described above. This, aside from the fact that there are several automatic curb dispensers of gasoline on the market. Water should also be made available.

Non-Skid Horse Shoe

Many inventions have been patented for the safety of the favorite equine in the Winter time, but all of them have failed to satisfy all demands upon them. Chains have been secured to the bottom of horse shoes, spikes have been welded on them and screwed into them, and various other things have been used to keep the quadrupeds from slipping on the ice and breaking their horsely necks. A prize of \$500 is offered thru the American Humane Association of Albany, N. Y., for the best non-slipping horse-shoe. This prize will be awarded on July 1st next.

As a suggestion I believe that a horse shoe with "V" shapt grippers welded to the bottom of the shoe would serve the purpose because of their peculiar shape and action relative to the motion and weight of the horse. Being "V" shapt the grippers should have a tendency to pack the snow and ice back of the horse's foot, thereby giving him a hold to pull forward. They would also act equally well going down hill or backing up, as the point of the "V" would cut into the ice and anchor the foot properly for the movement desired. The large sale of a successful invention of this kind would certainly make the inventor independent.

ACME

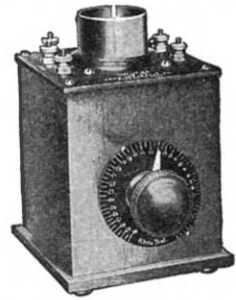

DETECTOR—AMPLIFIER

A complete detector (without tube)..... \$10.00
A single stage amplifier (without tube)..... 13.00

High amplification at low cost

Send for bulletin

ACME APPARATUS COMPANY

196 Massachusetts Avenue
Cambridge, 39, Mass.

Transformer and radio engineers and manufacturers

Service-- the Keynote

There is no guesswork about what GREBE RADIO apparatus will do. In design, workmanship and material it is built for the most exacting Service.



apparatus is licensed under the original Armstrong and Marconi patents. Our guarantee is absolute and unconditional. Each instrument must give satisfactory service. If your dealer doesn't carry our line, write us—mentioning his name—for catalogue.

A. H. GREBE & CO., Inc.

70 Van Wyck Blvd., Richmond Hill, N. Y.

KNOBBS

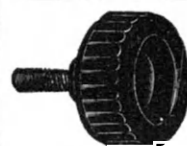

We have a large stock of knobbs as illustrated. This knob is made of "Insulate" and is 1 inch in diameter with a 1/8-inch A threaded shank. Just the thing for rotary switches.

No. 4 Knob, each 15c; Per dozen \$1.50
Shipping weight, each 2 ozs., per doz. 1 lb.

OTHER BARGAINS

Young & McCombs rotary spark gap, shipping weight 4 lbs. \$16.00
Young & McCombs saw tooth rotor, shipping weight 1 lb. \$4.50
De L...-est variable condenser, shipping weight 2 lbs special \$1.75
Skinderviken transmitter button, shipping weight 4 oz. \$1.00
Acme 1-2 K. W. semi-mounted transformer, shipping weight 30 lbs. \$22.00

Send 15c for our big illustrated catalogue. This amount may be deducted on your first order for \$1.50 or over. High printing costs make free distribution impossible.

ELECTRICAL SPECIALTY CO.

Dept. E. 48-50 S. Front St. Columbus, Ohio
Dept. E. 30 N. 9th St. Philadelphia, Pa.

LEARN WIRELESS

At the OLDEST, LARGEST and BEST EQUIPPED school of its kind in New England. Thousands of satisfied graduates all over the world. Splendid opportunities in the Merchant Marine, Day and Evening classes. Start any Monday. Illustrated Prospectus for the asking.

EASTERN RADIO INSTITUTE
699E Boylston St. Boston, Mass.



INTERPANEL SET

The Most Advanced Idea in Radio Telephone Transmitting and Receiving Apparatus

THE INTERPANEL Set consists of a series of panels, each comprising a complete piece of apparatus in itself, and designed to be combined with other panels, thus making a Set as complete as desired. The Set shown below contains these units, reading from right to left in the picture:

Complete Radiophone Transmitter, transmitting speech at least 30 miles; Type OT-3; two panels;
 Complete short wave Tuner of highest efficiency; Type MT-100; one panel;
 New Audion Control panel designed especially for tubes of the gaseous type, now considered as standard; Type MP-100; one panel; and
 One-step Amplifier complete in every respect; Type MP-200; one panel.
 (Additional steps of amplification may be added).



Complete Set of four units (five panels) mounted in cabinet, without batteries or tubes; \$189.25. Panels are also sold separately for mounting in home-made cabinet; or with legs for Vertical or Horizontal Table-style mounting. Get full particulars at once.

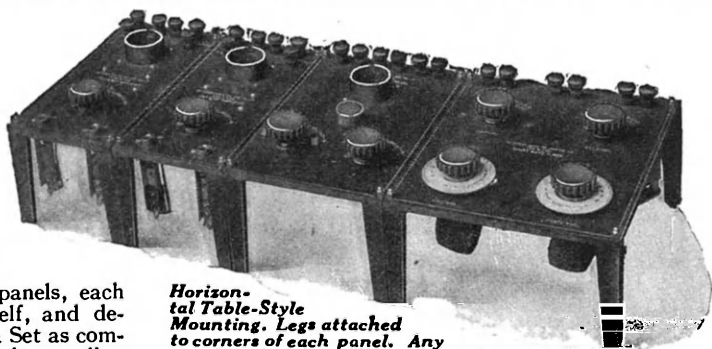

Horizontal Table-Style Mounting. Legs attached to corners of each panel. Any number of panels can be mounted in this style. Ample space under panels for batteries. Very convenient and inexpensive method of mounting.

PANELS are all 9 inches high, varying widths. Adaptable to any operating requirement and when placed side by side all binding posts are in line and convenient to wire.

30 Miles Range for the Telephone Transmitter on Average Amateur Antenna.

Only one 6-volt battery required for all filaments and microphone; motor-generator, "B" battery or rectifier supply may be used.

Send Now for Catalogue "E"

Get full details and place your order early to assure quick delivery.

De Forest Radio Tel. & Tel. Co.

Inventors and Manufacturers of High Grade Radio Apparatus.

1415 Sedgwick Ave.

New York City

WANTED—FOR CASH

Used Radio Apparatus of All Standard Makes

Our used wireless apparatus department, connected with our local retail store at 233 Fulton Street, New York City, is anxious to buy any radio instruments you may have for sale. These goods are for our New York customers only—we sell no used radio apparatus by mail. But we do have a tremendous call at our store for fine class goods and we will be glad to hear from you if you have any that you would like to dispose of.

WE PAY CASH

for all such merchandise that we buy, and this is an invitation extended to the radio fraternity to sell us their radio apparatus for which they have no further use. Write us in your first letter what make apparatus you have to sell, and your lowest spot cash price. It must be understood that all transportation is to be paid for by you. All goods to be sent to us prepaid either by parcelpost, express, or freight.

We can use only standard apparatus, no obscure instruments or home-made apparatus can be considered in any event.

If you have friends who wish to dispose of such apparatus, show them this advertisement. Also please note that your letter must state in just what condition the instruments are and that no goods must be sent to us unless we send you a written order to do so.

We invite amateurs residing in New York or vicinity to call at our store and inspect the used radio apparatus which will be placed on sale shortly after this advertisement appears.

Address all letters to

Used Apparatus Department

ELECTRO IMPORTING COMPANY

(Established 1904)

231 Fulton Street

New York City

Special Prices for Wireless Parts

D-L Inductance Coils Unmounted less 40%. DeForest Bleaching Condenser less 25%. Hot Wire Ammeter Roller-Smith 4 U Transmitting Station O-1 A, O-2.5A, O-5 A, O-10 A, \$7.00 each

Western Electric Telephones \$14

Before buying your complete apparatus or parts, call up AMERICAN ELECTRO TECHNICAL APPLIANCE COMPANY and get our prices. We carry a complete line of wireless goods.

Write for price list

American Electro Technical Appliance Co.

Dept. E, 235 Fulton St., New York City

MODEL STEAM LOCOMOTIVE

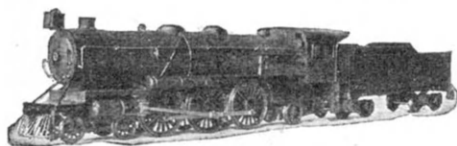

As illustration, with *braced* water tube copper boiler guaranteed to twice working pressure; *steel frames*; cast iron wheels on steel axles; *high efficiency* gunmetal cylinders; slip eccentrics for reversing.

Total length 3 feet. Gauge $2\frac{1}{2}$ inches. Ready to run. \$250.

Full set of machined parts with finished boiler, \$110.

(Requiring the use of hand tools only.)

FREDERICK DEY, Grand Ave., Englewood, N. J.

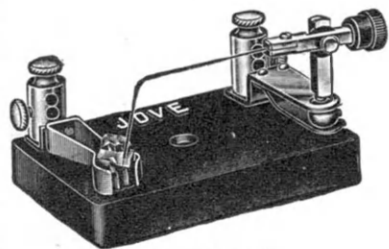

(GHEGAN PATENT)

Bunnell INSTRUMENTS
Always Reliable

JOVE DETECTOR

Handiest, Handsomest, Best
Sample by Mail — \$2.00
Tested Galena Crystal—25c

Distributors of Standard Electric Novelty Company Type B "Cyclone" Audion Batteries. Also De Forest, and all other makes of High Class Wireless Apparatus.

Send stamp for new edition 42E Catalog.

J. H. BUNNELL & CO., 32 Park Place, New York



Send for a Copy of Our Manual of Wireless Telegraphy

We now have ready for distribution our Manual of Wireless Telegraphy. It contains 200 pages, fully illustrating and describing the many instruments used in Radio. 45 pages cover general instructions, diagrams, station calls, tables, codes and other information identified with the art. The book is printed on high finished paper with a two-color cover and measures 9x5 $\frac{3}{4}$ inches.

Due to the scarcity of paper, the high cost of publication, and in order that the Manual may get into the hands of those most interested in Wireless, we ask 25 cents for it, give a coupon receipt for the amount, which coupon can be applied on a future purchase.

Get Your Copy Before the Edition Is Exhausted

MANHATTAN ELECTRICAL SUPPLY CO. INC.

17 Park Place
New York

114 S. Wells St.
Chicago

1106 Pine St.
St. Louis

604 Mission St.
San Francisco



Offers a thorough course in all branches of wireless telegraphy. Radio Operators earn at the start \$125.00 per month, and first-class board, etc., free. Our school prepares you for your license in three to four months. Positions guaranteed to first-grade licensed operators. ALSO MORSE TELEGRAPHY.

Day and Evening Classes

8 State Street, New York, N. Y.

Phone, Bowling Green 8079

Cobwebs

BY WILLIAM M. BUTTERFIELD

(Continued from page 24)

If any interest is aroused, it is by the wonderful silk productions which spiders weave and hang up in bountiful profusion in all sorts of places. It was thought at one time that the spider thread was similar to that used by the silkworm (*bombyx mori*) for constructing its cocoon, and some effort was made to obtain silk from large living spiders, by a kind of milking process in which a specimen is confined in a rack, and the silk drawn from one or more spinning tubes in long continuous threads.

The Spider's "Silk Factory"

The silk factory of the average spider is the most complicated mechanism of the kind known. The most complex—that of *stegodyphus*—consists in addition to three pairs of fingerlike spinnerets, of a comb-shaped sieve formed of 9,600 spinning tubes; as the capacity of each of the six spinnerets is at least a hundred threads, it can be seen that this particular machine has altogether a capacity of 10,200 threads which can be delivered,—all at the same time, for use in spinning.

As most spiders employ at least five kinds of thread, it is obvious that there are at least that many varieties of spinning tubes, in fact there are seven varieties known. The thread used by the Banded *Epeira* (*Argiopeidae*) a so-called orb-weaver, is about as follows—colors; white, yellow, red, brown and velvet black; varieties of thread—coarse, fine, smooth, globular, sticky, elastic, non-elastic, and occasionally, films of silk in ribbon form, also silk material churned up by the hind feet into a form resembling eiderdown.

All of these materials are delivered thru the variegated spinning tubes in proper form just at the time, and as Mrs. *Epeira* requires them. Using her hind feet as hands to regulate the blending of materials as they are delivered from the various spigots or conical tubes, she proceeds to form—say a web.

Most spider webs consists of two kinds of thread, a smooth white or grayish variety and a yellowish kind, viscid and with globules studded along it and at its contact with other threads shown in the outside spirals (or trap portion) of the hunting net—illustrated in our drawing. The variety portrayed is called an *orb-web*, and is thought to represent a vast amount of engineering skill on the part of the builder. The characteristic features are; a central platform supporting a series of radiating lines of dry *inelastic* thread, upon which are fastened in spiral form an *elastic* viscid thread in the manner shown. The methods used in sticking the threads together, and for anchoring the ends to any convenient object, is also illustrated—elastic, inelastic, viscid and dry threads are employed at the will of the builder.

Orb building spiders usually travel about with a thread always attached to their spinnerets and to the object upon which they are for the moment resting, this is called a *dragline*. The main portion, or inelastic part, of an orb-web is composed of this kind of thread, and the first strand is laid with the aid of a passing breeze, which conveys a purposely lengthened dragline away to a nearby twig or blade of grass, where it becomes en-

(Continued on page 90)

Paraffin—Its Properties and Use

(Continued from page 44)

which the wax is melted by torch or pressure gasoline furnace, is a common sight. The wax is produced in working up petroleum for kerosene and gasoline, and it occurs in nature, in great quantities, as a mineral called "ozocerite." The mineral is black, but this is due to impurity, and in refining, a pure white product results.

It is perhaps going too far to restrict the term *paraffin wax*, to that which chemists would call a paraffin or a mixture of paraffins. Paraffin wax is a mixture of a number of paraffins and is liable to have other hydro-carbons present in it.

A sieve or coffee strainer may have its gauze heated and rubbed over with paraffin. This may close all or some of the meshes. It is again heated and the paraffin is jarred out while liquid. It now shows no sign of the coating it has received. But if water is very carefully poured into it, there is no difficulty in making it hold a half-inch depth or more, so water repellant is paraffin.

A bright needle can be paraffined with the thinnest possible coating, and will float on water without difficulty. A clean needle will do this also, but paraffining it is to be advised. A canvas canoe can be made waterproof by applying a good coating of paraffin while hot. Sometimes the effect is to make the occupants can see the level of the water outside.

Paraffin can be used to make moulds for plaster of Paris castings, and can be softened by gentle heat, so as to be moulded around the pattern by kneading and pressure, to avoid the necessity of melting it.

1/10,000,000,000 Atmosphere Vacuum Pump

(Continued from page 30)

As for the degree of vacuum which may readily be obtained with the Langmuir pump the physicist would say—better than a ten-thousandth of micron. This can be expressed approximately as 1/10,000,000,000 atmosphere; but, even so, the statement lacks vividness, so let us try it this way.

First, to get an idea of what atmospheric pressure means in terms of molecules, suppose each molecule of air enlarged to the size of a fine grain of sea-sand or 1/100th of an inch in diameter. How big a beach could be made from the sand corresponding to the contents of a cubic inch of air at atmospheric pressure? It would make a beach extending from New York to San Francisco one thousand feet wide and over ten feet deep. Had it been on such a beach as this that Alice's friends were strolling when the walrus put his hypothetical question of seven maids with seven mops sweeping for half a year, there could have been no doubt in the carpenter's mind of the futility of their superstitious efforts. And yet by the aid of the Langmuir pump, assuming the sand were air again, that magnificent beach could, in a few minutes, be reduced to an almost invisible line, only two grains broad and one grain deep.

Invisible Man Next Marvel, Paris Hears

Dr. Vassiliev, a well-known Russian professor of anatomy, who startled the medical world with his discovery of a process for rendering dead human tissues transparent, is attempting to apply his discovery to the living human body.

He is now busied in his Paris laboratory working and dreaming of the time when the living human being can be made almost transparent if not entirely invisible.



Learn Telegraphy

(Wireless or Morse)

AT HOME

In Half the Usual Time

Let the OMNIGRAPH Teach You Wireless

"Just Listen—The Omnigraph will do the teaching"

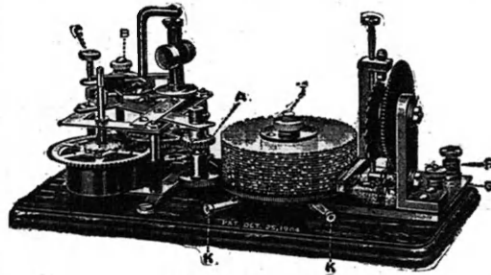

Write for Free Catalogue

For a few dollars you can have a complete outfit that will make you an experienced operator in the shortest possible time. No hard, laborious work—just learn by listening. The Omnigraph is adjustable so you can start receiving messages slowly, gradually increasing the speed as you become proficient. You'll be surprised how quickly you will attain speed. Even if you are already an operator the Omnigraph will help you. It will make you more proficient, more accurate and more confident. Thousands of Omnigraphs are in use today and thousands of operators owe their success to them.

The Omnigraph Mfg. Co., 26 B. Cortlandt St., New York City

The Omnigraph is an Automatic Transmitter that teaches you both the Wireless and Morse Codes, at home, without any expense except the cost of the machine itself. Merely connect to battery and your Buzzer, or Buzzer and Head Phones, or to your Sounder and the Omnigraph will send unlimited messages by the hour, at any speed you desire.

USED BY THE U. S. GOVERNMENT

The Omnigraph Mfg. Co. 26-B Cortlandt St. N. Y.

Gentlemen—

As per your ad in Science & Invention please mail me your free catalog of Omnigraphs.

Name.....

Address.....

City..... State.....

YOU Can Easily BUILD This PHONOGRAPH

TREMENDOUS SAVING IN COST

You don't need to be a cabinet maker. We have made it an easy and pleasant job with

Our Simplified Plans We furnish blue prints, diagrams, motor, ready-built horn, cabinet pieces and all metal parts complete. You do the assembling, **6 models to choose from**. A few hours' work, and you will have as fine a type of phonograph as any produced, and at a price away below what you would pay in a store.

KEEP THE SAVINGS IN YOUR POCKET

Machines play all records, have a wonderful tonal quality, excelled by none. No need now for any family to be without a phonograph because of the cost. **THE MAKAFONE** solves the problem. **BUILD IT YOURSELF AT LESS THAN ONE-FOURTH REGULAR COST**, but equal to the high-priced cabinet machines. Free Records with each outfit. **SEND TODAY FOR FREE CATALOG** and full particulars of our wonderful offer. *Many a manufacturer got his start in this way. Why not you? Build machines and sell to your friends.*

Agents Attention You can make and sell these machines from our plans at a profit of \$50 to \$75 each. Others are selling two and three a week. Here is your opportunity to make big money and become independent. Pleasant and profitable work.

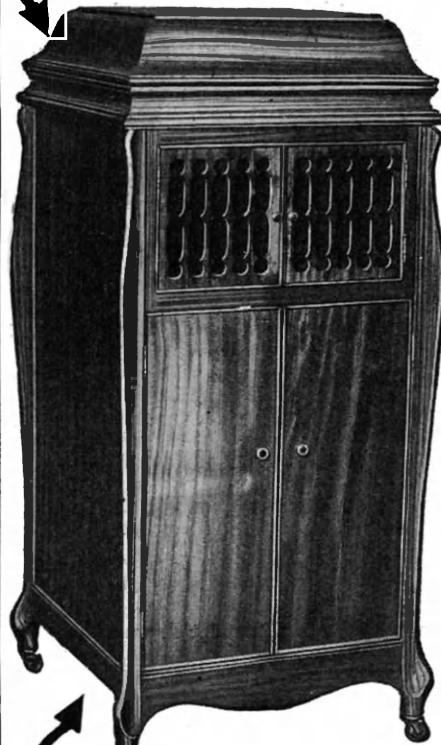

Send Coupon, Now—To-day

MODERN PHONOGRAPH SUPPLY CO.

583 Springer Bldg., 313 So. Clinton Street, Chicago.

Modern Phonograph Supply Co.

583 Springer Bldg., Chicago, Ill.

Gentlemen: Please send me full particulars of your Makafone Proposition, without obligation to me

Name.....

Address..... State.....

You can be quickly cured, if you

STAMMER

Send 10 cents for 288-page book on Stammering and Stuttering, "Its Cause and Cure." It tells how I cured myself after stammering 20 yrs. B. N. Bogue, 778 Bogue Bldg., 1147 N. Ill. St., Indianapolis.

DO YOU WANT ?

Prosperity! Power! Happiness! ?

Positive, Wonderful Results by Our System. "Success," Lesson and Personality Sketch for 10c and birth date.

THOMSON-HEYWOOD CO. Dept. 350 Chronicle Bldg. San Francisco

wireless for everybody



WITH this new Amrad Crystal Receiver you can pick up distant wireless telephone and telegraph messages any time, anywhere.

No elaborate aerial, batteries, license or special knowledge required. Easy to set up. Fascinating to operate.

Portable, compact, convenient. Only 5 x 5 x 7". Wavelength range 180 to 750 meters. Tunes sharply by simply rotating the knob. You can use an indoor antenna or the complete installation we furnish.

How often have you marvelled at the mystery of wireless? This wonderful phenomena has gripped the interest of thousands during the past few years. The Amrad Crystal Receiver brings this constant source of delight to everybody. You can now actually have a real "wireless" in your own home and hear the unseen voices of the air. This outfit is not a toy in any sense,—it is just the most practical and efficient Set a leading manufacturer of quality radio apparatus could build.

Illustrated Bulletin Y gladly sent free on request.

PRICES

- Amrad Crystal Receiver.....\$23.50
- Double Telephone Head Set..... 4.50
- Antenna and Ground Equipment... 12.00

Informative operating instructions included free with each set.

AMERICAN RADIO AND RESEARCH CORPORATION

Medford Hillside, Mass.

MASTER CONTINENTAL CODE DODGE SHORT CUT ONE HOUR METHOD INSURES SUCCESS

Thousands have. Everybody can. Testimonials free. Investigate and win. Costs 50 cents, Saves 50 dollars. C. K. Dodge, Box 300, Mamaroneck, N. Y.

**NEW 1920
REDHEAD PHONES**
\$12.50
We announce the new model of the famous Red Head Radio Receivers, greatly improved, 3,200 ohms. \$12.50 the pair.
THE NEWMAN-STERN CO.
Dept. E. E. Cleveland, Ohio
Distributors for DeForest, Murdock, Signal, Bunnell and other famous lines.

Cobwebs

By **WILLIAM M. BUTTERFIELD**

(Continued from page 88)

tangled, thus forming the first radiating line of a new web. Using this cable as a bridge the spider then walks to the center and sticks on a second line, which she conveys to its proper anchoring station. Carrying out this process she constructs all of the radiating and loop lines, in the meantime constructing the center platform. The viscid spirals, to which an insect becomes glued and entangled, are put in place last.

The thread in liquid form is secreted in various glands within the abdomen of both the male and female spider. There are several forms of glands connecting with their spinning tubes, each form having its special function. This liquid substance on passing thru the spinning tubes is congealed by the atmosphere and becomes more or less hard, and possesses a water-proof surface. The dry kinds resemble chitin, or the horny substance forming the covering or skeleton of insects, it is unlike chitin in its being soluble in rainwater however. Each thread is composed of two or more strands that coalesce or stick together without twisting, and are somewhat stronger than the silk of the silk-worm, or as compared with threads of flax of the same diameter in the ratio of 136 to 47, and of hemp in the ratio of 102 to 40. The male and female do not occupy the same web, each builds its own web and inhabits its own domicile. In the construction of an egg-sac, her *chef d'oeuvre*, she employs all of her skill, and all of her store of silk to the last drop. Every variety of thread, every color procurable in her wonderful *silk factory* is employed. And why not? The work is a sort of death or swan song to end Epeira's last day. The penalty of motherhood in her case is death, and as soon as the sac is completed she will crawl weakly away without once glancing at her work, to some nearby crevice to die.

But how was this wonderful storehouse for her orange-colored eggs made? Surely not by the aid of vision, for from the time the work was started to its completion she worked with her back turned, her spinning machinery working as we might say, automatically. First there are a few threads hung between three or four blades of grass, these supporting a pendant, oblong sac about the size of a small plum, the latter consisting of various layers of silk fabric of several different colors and textures making altogether, a water, heat and cold-proof hanging envelope.

The fabrics are, first, a ball-shaped pocket of the daintiest white satin in which Mrs. Epeira deposited her eggs at the moment it was completed,—strange to say, this little pocket just fitted the ball of eggs like a glove. Next the investment consists of an insulating felt blanket, composed of fluffy web resembling eiderdown or like a wadding of yellow silk. Over this is a net of reddish silk, then a coarse thick outer covering of strong cloth woven in the form of a pear-shaped flask, with a turned over and embost lip ornamenting the small opening at the top. This layer is further decorated with designs woven from black and brown silk on a white ground work. A cork of white wool, held in place by a few strands of thread binder closes the mouth of the sac.

YOU want a Radio School that will train you to be a First Class Radio Operator—at the least expense—in the shortest possible time—and help you to secure a good paying position.

Write today for our latest booklet that explains our methods in detail. If you are an ex-Service man ask us about our special scholarship plan.

Y.M.C.A. Radio School

152 East 86th Street, N. Y. C.

"The Best Radio School in the East"

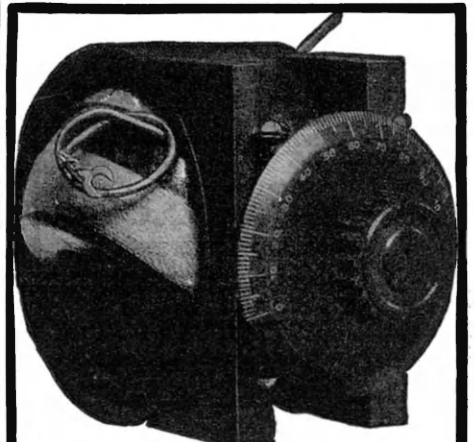

Z. R. V. Variometer for \$6.50 Short Wave Lengths

Complete catalogs of Radio Apparatus sent for 6 cents in stamps.

CLAPP-EASTHAM COMPANY
131 Main St. Cambridge, Mass.

Write for Remler Bulletins Nos. 1001 and 1002

Gives full description and prices on Remler Apparatus

"Apparatus that Radiates Quality"

REMLER RADIO MFG. COMPANY
163 Sutter St., San Francisco, Calif.

200 Big Pages,—

check full of the latest radio equipment—that describes Kelly & Phillip's new radio catalogue, just off the press. Printed on good stock, attractively bound. It lists every reliable make of radio equipment, at the lowest prices. Contains valuable information and data that you will use every day. Price 25 cents, refunded on first purchase of \$2.50 or over. Send to-day for your copy of the world's largest radio catalogue. **KELLY & PHILLIPS,** 312 Flatbush Avenue, Brooklyn, New York

RADIO CLUB PINS

Special folder of designs and prices in addition to regular School pin catalog free on request. Be sure to see these new numbers which will put new life in your club.

METAL ARTS CO.
Dept. 12 Rochester, N. Y.



LIBERTY AUTOMATIC REVOLVER

HIGH QUALITY - RIFLED BARREL - GOOD VALUE

With Shell - Ejecting Device

PRICE

\$9.50

.22 Cal. .32 Cal. .38 Cal.



One of the most powerful and effective weapons made. The shots can be fired rapidly and in succession, as fast as you can count. The ideal weapon for Express Men, Bank Agents, Pay Roll Clerks, Automobileists, and all others where quick action is absolutely essential. Accidental discharge impossible. Another feature is the **Automatic Shell Ejector**, that throws the empty shells out when the barrel is tipped down. The Revolver is exceptionally well made of the finest materials and scientifically tested for accuracy. Fitted with fancy rubber handle. .22, .32, or .38 calibre, **PRICE \$9.50, postpaid anywhere; Cartridges for above Revolvers - by express only, .22 cal. \$1.00 per 100, .32 cal., \$2.50 per 100; .38 cal., \$3.50 per 100.**

BLANK CARTRIDGE PISTOL

This well made and effective Pistol is modelled on the pattern of the latest type of Revolver, the appearance of which alone is enough to scare a burglar, whilst, when loaded, it will probably prove just as effective as a revolver with real bullets, without the danger to life. It takes the standard .22 Calibre Blank Cartridges, that are obtainable most everywhere. Even the most timid woman can use it with perfect safety and frighten a thief without risk to herself or anyone else. A Great Protection Against Burglars, Tramps and Dogs. You can have it lying about without the danger attached to other revolvers. We sell large numbers around the 4th of July. Well made of Solid Metal, **PRICE ONLY 50 CENTS Postpaid.** Better make and superior quality for \$1.00. Blank Cartridges .22 cal., shipped by express only, customer paying expressage 50c Per 100.

PRICES

50c. \$1.00



MELIOR AUTOMATIC PISTOL

SHOOTS .25 CAL. COLT Cartridges



Best value in Automatics in America. Shoots Colt .25 Cal. Automatic Cartridges, 7 Quick Successive Shots. The Pistol takes seven cartridges at one loading; extra magazines can be kept ready for instant reloading. Each empty shell is automatically ejected immediately after firing. Fixed stationary barrel, ensuring great accuracy. Trigger action is exceptionally light and quick, and must be pulled back for each shot. Safety Lock disconnects the pistol when not in use. **WEIGHT OVER ALL - less than five inches, 4 in. Barrel.** Material, workmanship and finish of the highest possible grade throughout. A wonderful combination of **ACCURACY and RELIABILITY.** Superb shooting qualities; as easy to aim as pointing the finger; works as smooth as an engine; will shoot through four inches of pine wood. Fine for target shooting. Weighs only 12 oz. Sold under positive guarantee to shoot equal to any pistol on the market or money refunded. **PRICE, \$15.00 post. Cartridges (express only) \$3.75 per 100.**

MELIOR AUTOMATIC .32 CALIBRE PISTOL

This Pistol may also be had in .32 Calibre, same as above, length of barrel nearly 4 inches, length over all less than 7 in. **PRICE, \$20.00 postpaid. .32 Cal. Automatic Cartridges, (by express only) \$4.50 per 100.**

"The Baby" Double Action Revolver

A Handsome and Most Effective Weapon. Measures But 4 1/4 inches long. Takes Regular .22 Calibre Cartridges **\$5.00**



The new Baby Double Action Hammerless Revolver has been produced to meet the ever increasing demand for a revolver that would combine small size and light weight with the essential features of Efficiency and Practicality. It is small in size, yet is just as effective and serviceable as the most expensive weapon you can buy. Everyone should have a revolver and should know how to use it, and there is no safer or better one made than this. A great feature is its safety action that guards against accidental discharge, making it quite safe for young men and ladies. The illustration gives an idea of its appearance, but it must be seen and used to be thoroughly appreciated. The ammunition used is the standard .22-calibre cartridge obtainable anywhere. The operation of the charging mechanism is extremely rapid and absolutely reliable. Six well aimed shots can be fired in as many seconds. The revolver is very well constructed, with finest nickel plated fitted barrel of cylinder, and it weighs only 4 1/2 ounces. The price of the Baby Revolver is only \$5.50, sent by mail, post. is not added.

Write For FREE Catalog of Revolvers.

JOHNSON SMITH & COMPANY, Dept. P. M. 73, 3224 N. Halsted St., CHICAGO

THE LATEST "MURDOCK" VARIOMETER



No. 345

"MURDOCK" VARIOMETER

\$7.50

THE PRICE IS UNUSUALLY LOW

THE QUALITY IS REMARKABLY HIGH

WINDING FORMS ARE "MURDOCK" MOULDED

No. 55

Head Phone

The continued great demand for these receivers is a wonderful tribute to their extraordinary value, by thousands of satisfied customers. If you are skeptical as to the possibility of so much value at so small a cost, **ASK YOUR DEALER.** We suggest a trial with the assurance of "satisfaction or your money back."

BULLETIN No. 20 Sent anywhere on request.

2000 \$4.50

OHM.

3000 \$5.50

OHM.

Wm. J. Murdock Co., 55 Carter St., Chelsea, 50, Mass.

509 Mission St., San Francisco, Cal.

FREE  **HERE'S MORE MONEY for YOU**
Valuable Book FREE

This Free Book has been the stepping stone to success for thousands of young men. It illustrates and describes hundreds of **Practical Home Study Self Helps**. No matter what line of work you are in, or want to take up, you are sure to find money-making help here. Write today for your free copy. Here are also a few of our up-to-the-minute

ELECTRICAL BOOKS

- Armature and Magnet Winding..... \$1.75
- Wireless Telegraph and Telephone Handbook 1.25
- Telegraphy Self Taught..... 1.25
- Modern Electrical Construction..... 1.75

AUTO BOOKS

- Automobile Ignition..... 2.00
- Automobile Starting and Lighting... 2.00
- Brookes' Automobile Hand Book..... 2.00
- The Ford Motor Car, Truck & Fordson Tractor 1.50
- Automobile Battery, Care and Repair. 2.00

CARPENTRY BOOKS

- Modern Carpentry, 2 vols..... 3.00
 - The Steel Square and Its Uses, 2 vols.. 3.00
 - Wooden Boat and Ship Building..... 1.50
- All books sent post paid upon receipt of price. Order from this ad. Hundreds more in our big catalog, sent free.

FREDERICK J. DRAKE & CO.,
 1009 Michigan Ave., Chicago
Drake Books Are For Sale at All Book Stores

Play the Hawaiian Guitar

Just Like the Hawaiians!

Our method of teaching is so simple, plain and easy that you begin on a piece with your first lesson. In half an hour you can play it! We have reduced the necessary motions you learn to only four—and you acquire these in a few minutes. Then it is only a matter of practice to acquire the weird, fascinating tremolos, staccatos, slurs and other effects that make this instrument so delightful.

The Hawaiian Guitar plays any kind of music, both the melody and the accompaniment. Your tuition fee includes a beautiful Hawaiian Guitar, all the necessary picks and steel bar and 52 complete lessons and pieces of music.



Special arrangements for lessons if you have your own guitar.

Send Coupon NOW
Get Full Particulars FREE

First Hawaiian Conservatory of Music, Inc.
 233 Broadway NEW YORK

I am interested in the HAWAIIAN GUITAR. Please send complete information, special price offer, etc., etc.

Name
 Address
 Town..... State..... E. E.

Write Name and Address Clearly



FLYING MODEL AIRPLANES
 JUST OUT -
 OUR NEW CATALOGUE 52 PAGES
Walling & Wynn, Co.
 EST. 1909.
 672 B-WAY SEND 10¢
 B KLYN, N.Y. FOR ONE

A Compensated Selenium Cell

By W. L. GRIPENBERG
 (Continued from page 44)

proposed and actually built by the writer.

The upper illustration represents—in nine times magnification—the electrodes (towards the light) of both circuits; those of the "feeler"-cell consist of grids or gratings so that the selenium immediately behind it is amply lighted, whereas the compensating circuit has opaque electrodes.

The direction of the current is perpendicular to the surface of the selenium (and electrodes) and parallel to the rays of light.

The electrodes consist of a thin film of platinum (or gold) and are engraved by means of the dividing-engine.

At the back the electrode is whole, common to both circuits and of same material (as otherwise electro-chemical difficulties may ensue).

The middle figure is a section of the cell perpendicular to them.

Lastly there is a perspective view of the whole arrangement with the exception of the screw-press by means of which the electrodes are firmly prest against the selenium plate.

The connections are also shown here: the grids—A and B—are connected to the dissimilar poles of the two batteries. The back electrode A-B is joined with one binding-post of the apparatus to be worked, whereas the other goes to the remaining poles of the batteries.

The current produced in the bridge (apparatus) by lighting became sooner stationary than the main current; thus there was artificial, rapid "recovery" of the photo-current—the so-called inertia of the cell was lessened.

The effect obtained by Korn in his selenium-compensator was here reproduced on a smaller scale. The cause lies in the diffusion of the photo-effect into the compensating circuit; it receives the equivalent of a very feeble illumination and as in this case the recovery is very slow, so the last part of the recovery curve in the "feeler"-circuit is annihilated.

The new electro-chemical compensation was discovered in the following way: In order to test the specific resistance of a selenium plate the cell was used as a "simple" one. Both grids were connected to the same pole of one battery, the back electrode to the other. Then appeared the rather frequent feature that the current was not constant: the needle of the instrument received sudden jerks and shocks; it moved to and fro irregularly.

As, however, the compensation connection with two batteries was established, the irregularities vanished!

Electric Toy Gun

(Continued from page 45)

also allowing for a vertical swing. Its bore can be anywhere from 1/4 to 1/2 inch in diameter, dependent upon the size projectile to be fired.

The magnet at the end should be about two inches long, and have a depth of winding of about 3/8 of an inch. No. 20 wire is used on voltages up to about 6, and No. 22 wire is used on higher voltages up to 12.

The commutator for the machine gun action in rapid firing consists of an ordinary gear wheel taken from an alarm clock from which all but two opposite teeth have been removed. A long piece of spring brass conforming with the curvature of the sprocket wheel, and allowing for 1/3 distance contact as our illustrations clearly show is used as a brush



LEARN TO DANCE AT HOME

Learn all the new steps. Equip yourself with the finest of social graces. This wonderful new Movie Method of Dance Instruction simplifies and makes instantly clear every aspect of the Dancing Art. It comes to you from America's foremost authority on Ballroom Dancing, the instructor who has successfully taught thousands in person and by mail. Let him teach you.

THE GOOD DANCER IS ALWAYS WELCOME

Social life revolves around the graceful swaying of laughing, joyous couples liding through the modern dances. And if you are correctly taught the art of dancing is easily and quickly acquired in your own home.

SAMPLE LESSON 25 CENTS

Just to give you an idea of how remarkable and practical and simple this New Method is. Additional lessons 50c. Send 25c. for sample lesson today—and learn how easily you can master the art of fine dancing.

A. M. SYSTEM OF DANCING
 Dept. 265 290 Broadway, New York



CARPENTERS, Shipfitters, Bricklayers, Structural, Concrete and Sheet Metal Workers, Electricians, Mechanics Plumbers, Pipefitters, Boilermakers— can you read Blue Prints and hold a big job? If not, learn how. It will help you hold your job—it will get you a better job—it will increase your earning capacity. **DON'T DELAY**—it means more money! Write for Catalog Bf stating trade.

BE A DRAFTSMAN

Earn \$35-\$150 Week

Draftsmen are in demand. Books and tools FREE. Write for Catalog G. **DO IT TODAY!**
 Columbia Correspondence School Est. 1904
 Dept 1, Drexel Bldg., Phila., Pa.

PHONOGRAPH USERS

Stop that Scratchy Sound of Your Phonograph



The Universal tone modifier will eliminate the annoying, harsh, scratchy sound, producing soft and clear music. A simple adjustment of the modifier will change the music to loud or soft. No need of using different tone needles. Can be attached to any machine except Edison. Send \$1.00 and we will mail at once one of the Universal Tone Modifiers, postage prepaid.

100% Better Music Pat. May 11, 1920 Money Refunded if Not Satisfactory

Universal Phonograph Attachment Company

1644 S. Karlov Ave., Dept. 10, Chicago, Ill.

Make-UR-Own Wireless "B"-Batteries

The greatest invention in Radio Field—economical and absolutely dependable and harmless. With a Make-UR-Own Battery outfit you can have new batteries, or 2 or 3 cells to replace those that have gone dead. In just a few moments, and you will have a better battery—a battery that is fresh and lasts longer. The outfit consists of wooden case with binding posts for two voltages, and material for thirty 1.5 volt cells. Every Radio man needs one. Send today.

\$6.75 Complete

Send Money Order, Check or P. O. We Pay Transportation Charges

RADIO PRODUCTS SOCIETY

Dept. 1352 Peoples Gas Bldg. Chicago, Ill.

SECRET SERVICE

Operatives, Detectives and Investigators are in big demand; earn big salaries; fascinating work. Be independent. We show you how by home study. Write American School of Criminology, Dept. B, Detroit, Mich.



THIS BOOK ON HOME BEAUTIFYING Sent Free

Contains practical suggestions on how to make your home artistic, cheery and inviting. Explains how you can easily and economically keep the finish of your woodwork, floors and furniture in perfect condition.

DECORATING?

This book gives complete instructions for finishing both hard and soft woods in enameled effects with **Johnson's Perfect Tone Enamel**—and in stained effects with **Johnson's Wood Dye**. We will gladly send you this book free and postpaid. When writing, please mention the name of your best dealer in paints.

Tell your painter and architect that you want your floors and interior trim finished with Johnson's Artistic Wood Finishes. Then you will be assured of satisfactory results when the work is new, and yearly satisfaction at its wearing qualities.

S. C. JOHNSON & SON, Dept. S. I. 5, Racine, Wis.
"The Wood Finishing Authorities"

Popular Astronom Sun Spots and the Weather

By ISABEL M. LEWIS
(Continued from page 37)

range being anywhere from three to ten per cent of the total value of the radiation constant. It is these short period variations that mask and at times reverse the effect of the longer period variations, and increase the complexity of the attendant atmospheric phenomena. The determination of the atmospheric effect of these solar constant variations is largely a matter of experience and as more observations are obtained and the attendant atmospheric phenomena observed the law of association of the two should become more evident.

As to the cause of the two types of variation, it is believed that the longer period variation associated with the sun-spot cycle is due to changes in the heat of the sun itself, while the short period changes arise from changes in the transparency of the solar atmosphere.

It is well known that the center of the sun's disk is brighter than the edges and it has been found that the contrast between the two keeps changing, not only during the sun-spot cycle, but from day to day evidently as the transparency of the solar atmosphere changes. This contrast of the center and edges arises from the absorbing effect of the cooler gases of the sun's atmosphere. The rays that come to us from the edges of the sun have to traverse a longer path through the denser solar atmosphere than the rays that come to us vertically from the center of the disk.

The case is analogous to that of light passing through the atmosphere of the earth. Light coming into the earth's atmosphere, from objects near the zenith, is less obstructed by atmospheric vapors than light from objects near the horizon, which light must travel for greater distances through the denser low-lying strata of the air.

The hotter the sun and the more intense its radiation the greater the contrast between its center and its edges. But the hotter the sun the more its atmosphere is filled with dense vapors of many elements and the more effectively its short wave length radiations are entrapped. In other words two conflicting agencies are at work, increase of solar radiation, on the one hand, and increase of its absorption by the solar atmosphere, on the other hand. When the passage of solar radiation is temporarily retarded by the dense atmospheric vapors, its intensity increases until finally it breaks thru the enveloping gases in local disturbances producing great eruptive prominences and similar signs of great solar activity. Temporary and local retardations of solar radiations by solar atmospheric gases may produce the irregular short period variations of solar radiation that are superimposed upon the longer period variations attending the sun-spot cycle.

It is not necessarily the sun-spots that cause temperature changes and other effects in the earth's atmosphere but rather changes in the intensity of solar radiation or in the transparency of the solar atmosphere. The local seat of the disturbance, if there is one, may lie far from the sun-spot region or there may be a general increase in short wave length radiations from the sun as a whole, that sets up important temperature effects in the earth's atmosphere.

ROTH

PROTRACTOR

DRILL LEVELS



\$2.00

Will make your drill "STAY ON THE LEVEL"

When you know that you can drill holes accurately at any angle, you will want a Roth Protractor Drill Level. Easily attached to any kind of drill. Hand-Chain or Electric. It saves time and assures better work.

You know what this Level will do for you. Mention type of drill you are using. Postage prepaid.

PROTRACTOR LEVEL CO.
620 Arctic Avenue Atlantic City, N. J.

This Book Free

"Success in Music and How to Win It" Sousa and nine other world-famous musicians tell how you can quickly learn to play saxophone, cornet, trombone, clarinet, any band or orchestra instrument and double your income and pleasure.

Free Trial Any Conn Instrument

Used by greatest bands and solo artists. Highest honors at world expositions. Bestest of all to play. Send postcard for free book and detail of free trial plan.

C. G. CONN, Ltd.
556 Conn. Bldg., Elkhart, Ind.

World's Largest Manufacturers of High-Grade Band and Orchestra Instruments.

SEXUAL KNOWLEDGE

320 Pages ILLUSTRATED Cloth
By Winfield Scott Hall, M. D., Ph. D.

SEX FACTS MADE PLAIN

What every young man and Every young woman should know
What every young husband and Every young wife should know
What every parent should know

Table contents and commendations on request

\$1.00 Postpaid

Mailed in plain wrapper

AMERICAN PUB. CO.
545 Winston Bldg., Philadelphia



HIGH SCHOOL COURSE IN TWO YEARS

You Want to Earn Big Money!

And you will not be satisfied unless you earn steady promotion. But are you prepared for the job ahead of you? Do you measure up to the standard that insures success? For a more responsible position a fairly good education is necessary. To write a sensible business letter, to prepare estimates, to figure cost and to compute interest, you must have a certain amount of preparation. All this you must be able to do before you will earn promotion.

Many business houses hire no men whose general knowledge is not equal to a high school course. Why? Because big business refuses to burden itself with men who are barred from promotion by the lack of elementary education.

Can You Qualify for a Better Position?

We have a plan whereby you can. We can give you a complete but simplified high school course in two years, giving you all the essentials that form the foundation of practical business. It will prepare you to hold your own where competition is keen and exacting. Do not doubt your ability, but make up your mind to it and you will soon have the requirements that will bring you success and big money. **YOU CAN DO IT.**

Let us show you how to get on the road to success. It will not cost you a single working hour. We are so sure of being able to help you that we will cheerfully return to you, at the end of ten lessons, every cent you sent us if you are not absolutely satisfied. What fairer offer can we make you? Write today. It costs you nothing but a stamp.

AMERICAN SCHOOL
Dept. H-526 Drexel Ave. & 58th St., Chicago

American School

Dept. H-526 Chicago, Ill.

Explain how I can qualify for position checked:

.....Architect \$5,000 to 15,000Lawyer \$5,000 to \$15,000
.....Building Contractor \$5,000 to \$10,000Mechanical Engineer \$4,000 to \$10,000
.....Automobile Engineer \$4,000 to \$10,000Shop Superintendent \$3,000 to \$7,000
.....Automobile Repairman \$2,500 to \$4,000Employment Manager \$4,000 to \$10,000
.....Civil Engineer \$5,000 to \$15,000Steam Engineer \$2,000 to \$4,000
.....Structural Engineer \$4,000 to \$10,000Foreman's Course \$2,000 to \$4,000
.....Business Manager \$5,000 to \$15,000Sanitary Engineer \$2,000 to \$5,000
.....Certified Public Accountant \$7,000 to \$15,000Telephone Engineer \$2,500 to \$5,000
.....Accountant & Auditor \$2,500 to \$7,000Telegraph Engineer \$2,500 to \$5,000
.....Draftsman & Designer \$2,500 to \$4,000High School Graduate In two years
.....Electrical Engineer \$4,000 to \$10,000Fire Insurance Expert \$3,000 to \$10,000
.....General Education In one year	

Name..... Address.....

Learn Music At Home!

New Easy Method



Piano, Organ, Violin, Drums and Traps, Saxophone, Flute, Clarinet, Ukulele, Trombone, Cornet, Guitar, Banjo, Mandolin, Harp, Cello, Sight Singing. No longer need the ability to play be shut out of your life. Just write us a postal today for our new Free Book, fresh from the printer. Let us tell you how you can easily, quickly, thoroughly learn to play your favorite musical instrument by note in your own home, without teacher, by our New Improved Home Study

Method, *without paying a cent for lessons!* Different, easier than private teacher way—no tiresome, dry exercises—no inconvenience. No trick music, no "numbers," yet simple, wonderful, amazingly easy for even a mere child.

250,000 Pupils!

We have successfully taught over 250,000 people, from seven to seventy, in all parts of the world! Hundreds write—"Have learned more in one term in my home with your weekly lessons than in three terms with private teachers." "Everything is so thorough and complete." "The lessons are marvels of simplicity." My 11-year old boy has not had the least trouble to learn.

Wonderful New Book Free!

We want to have one pupil in each locality at once to help advertise our wonderful easy system of teaching music. For a limited time, we therefore offer our marvelous lessons at practically no cost. Charges amounting merely to about the cost of sheet music, postage, etc. Beginners or advanced pupils. We have hundreds of pupils right here in New York, the musical center of America, who prefer our Home Study method in place of best private teacher. Get all the proof, facts, letters from pupils, amazing offer and fascinating New Book just issued, *all free!* Write postal today. Address

U. S. School of Music, 1335 Brunswick Bldg., New York

No Batteries Needed

HAND GENERATED CURRENT FLASHLIGHT

Gives brilliant light at no operating expense
ELECTRO-AUTOMATE

PRICE \$7.20
Postpaid
Special Offer

Saves cost of batteries and will soon pay for itself. Nothing to get out of order—lasts a life-time. The best electric lamp when hunting or camping. Keep one in your auto or motor boat. Always ready. **Order at once!**

Send check, M. O., or cash to
ELSAESSER & WATTS

138 Liberty St. (Dept. 1) New York City

ACCOUNTING COST-C.P.A.-EXECUTIVE

Just what you have been looking for—a chance to learn practical accounting thoroughly under the personal guidance of the largest active faculty of Certified Public Accountants in the U. S. New loose-leaf course and exclusive result-getting methods enable us to turn out more successful men than any other institution in existence. Post Graduate Courses enable you to specialize in any desired branch without additional cost. Write for handsome new book and full details. Moderate cost—easy terms.

INTERNATIONAL ACCOUNTANTS SOCIETY (Incorporated)
Dept. 521 2626 South Michigan Avenue, CHICAGO

MATHEMATICS MADE EASY

The Arascope—the Combination Triangle with a Brain—will multiply, divide, figure percentage and proportion, solve all problems in trigonometry and geometry, draw symmetrical figures, plot arcs, etc. Superior to any slide rule. Simple to operate. Also includes a **TRANSPARENT TRIANGLE, PROTRACTOR** and **THREE BULBS**. Used at Columbia University, West Point, U. S. Aeronautic Schools, etc. Only One Dollar Postpaid. Order today before you forget.
Dept. J, L. J. LEISHMAN CO., Ogden, Utah

The connection between variations in the intensity of solar radiation as determined by the Smithsonian Institute during the period 1905-1920 inclusive and changes in temperature and rainfall in Argentina as well as in various other parts of the world has been extensively investigated by the Chief Forecaster of the Argentine Meteorological Service, Mr. H. H. Clayton, and his results show a very marked correlation of temperature and rainfall throughout the world, with solar-constant variations. The changes in the solar-radiation constant as determined at Calama, Chile, is telegraphed to Buenos Aires daily and is made the basis of forecasts of estimated temperatures for each day, and expected rainfall for a week in advance. Great interest has been shown by the Argentine government as well as by commercial interests in the practical results of Mr. Clayton's forecasts, and an appropriation has been made by the legislature of Argentina for the establishment of a solar observatory.

It has been found from the investigation of this long series of solar radiation observations and attendant weather changes that the correlation between the two is exceedingly complex owing to the two-fold nature of the solar variation and the irregularity and uncertainty of the short period variations.

Two interesting points brought out by Mr. Clayton in a recent article for "Nature" are, first, the cumulative effect of changes in solar radiation which makes a long period change of solar radiation of small range more effective than a short period change of greater range; and, secondly, the fact that as the sun passes from one hemisphere to the other there is a reversal of the temperature effect, the atmospheric pressure falling over land and rising over water in the hemisphere where the sun's rays fall more nearly vertically. These reversals complicate the prediction of weather changes in the spring and fall.

The average value of the solar constant of radiation as determined by the Smithsonian Institute is 1.93 calories. It will be remembered that this is the amount of heat received per square centimeter per minute *outside the earth's atmosphere* at the earth's mean distance and at right angles to the direction of the solar beam.

Of course all observations must necessarily be made *within* the earth's atmosphere and since the transmission of solar energy by the earth's atmosphere varies for different wave lengths the observations must be made for various wave lengths and the results extrapolated for a point outside of the atmosphere.

Observations of the energy of solar radiation are made by means of the spectrophotometer, an instrument which is made to trace photographically within ten minutes a solar spectrum energy curve reaching from wave length 0.3 to 3.0 microns.

Six solar spectrum energy curves are traced by this instrument a day at each station. The first record is made when the sun is 15° above the horizon and the last when its altitude is about 60°. These curves are then measured at about forty points from far in the infrared to far in the ultra-violet. From this data it is possible to obtain the intensity for each wave length, as it would be outside the earth's atmosphere and these observations in conjunction with the readings of a pyrheliometer give the data for finding the total energy received from the sun per square centimeter per minute outside the atmosphere. The range of the solar constant of radiation according to observations made at Calama, Chile, from July, 1918, to March, 1920, was between 1.88

The Boys' Magazine FREE!

Send us the names and addresses of 10 boys (from 10 to 16 years old) and we'll send you a copy of this splendid magazine FREE. Great stories—beautiful illustrations—handsome covers in colors. Departments devoted to Wireless, Electricity, Mechanics, Athletics and Physical Training, Moving Picture Plays and Players, Cartoons and Jokes. (Write plainly.)

Address

THE SCOTT F. REDFIELD CO.
6028 Main St., Smethport, Pa.

THE BOYS' MAGAZINE on sale at all newsstands, 15c a copy

Gibson Instruments

Mandolin, Mandola, Mando-Cello, Guitar, Tenor-Banjo, Mandolin-Banjo, Cello-Banjo, Guitar-Banjo, Sarr-Banjo, Guitar, Mando-Bass



Easy to Play Easy to Pay

Select your Gibson now. You can soon be playing the music of the day. Your friends will be surprised and delighted. Let us help you organize a Gibson Orchestra in your community. You can increase your popularity, income and pleasure by playing for Concerts, Entertainments, Church Affairs, etc. A small down payment and then \$5 a month will soon pay for a Gibson and will furnish you with wholesome, year-round entertainment. If you have an old instrument, we will make liberal allowance on a Gibson. Write for Free Book, Catalog, Free Trial Offer, information about Wm. Place, Jr. Book and the instrument you prefer.

GIBSON MANDOLIN-GUITAR CO.
1065 Parsons St., Kalamazoo, Mich., U. S. A.

Do You Need MONEY?

If you are making less than \$150 a month, write me today. I have no "get-rich-quick" plan. But if you are wide-awake, honest, willing to work with me and give me at least part of your time, I offer you

MAN OR WOMAN
the Special Agency (local or traveling) for our great line of Household Necessities. Experience is unnecessary. I will furnish everything, so that lack of capital shall not stand in your way. Hundreds of prosperous men and women who started this way are now making \$150 a month and more. It's your great opportunity—and I may don't miss it. Just drop me a post card today for complete particulars FREE.

Albert Mills, Mgr. 3019 American Bldg., Cincinnati, O.

"Lighting Fixtures"

Ready to Hang
(Direct from Manufacturers)
Completely wired, including glass-ware. New designs.
Send for catalog No. 20
ERIE FIXTURE SUPPLY CO.
Sta. C Erie, Pa.

Book on Law Free

Write today for our new 171-page book on "The Power of Law Training." It carries a vital and inspiring message to every ambitious man. Find out about the opportunities that await the law trained man. Find out how you can learn from masters of the law right in your own home. No obligations. The book is absolutely FREE.
Write Today—now while we are making a special reduced price offer.
American Correspondence School of Law
7445-2601 Michigan Ave., Chicago, Ill.

'FIBRE-LITE' LIMBS

Easy Payments—Do Nature's Work. AGENTS WANTED who wear leg. Good Pay. FREE Fibre Sample.
Describe Stamp to
WORMAN CO., 252-D HENNEPIN, Minneapolis, Minn.

I TEACH BY MAIL
WRITE FOR MY FREE BOOK
"How to Become a Good Penman"
and beautiful specimens. Your name elegantly written on a card if you enclose stamp. Write for it today. F. W. TALLEY, 424 Meyer Bldg., Kansas City, Mo.

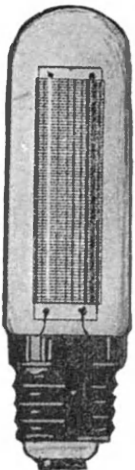

Selenium Cells

(NEW PROCESS)

Highly Sensitive. Quick Acting. Permanent. Uniform in Quality.

Sizes and types for all uses.

OFFER A NEW FIELD FOR THE INVENTOR

Send for illustrated Catalog A describing interesting electrical behavior of this metal under varying light conditions.

Richardson, Cook & Seixas, Inc.
154 Nassau St. New York, N. Y.

Send No Money 6000 Miles Guaranteed



Here is the greatest and most sensational sale of the season. Park Double Tread tires are scientifically reconstructed, and guaranteed for 6000 miles or more.

LOWEST CUT PRICES

Send no deposit. Pay after you have carefully examined and are convinced of their wonderful long wearing qualities. Heavy reliner free with every tire.

SIZE	TIRES	TUBES
30 x 3	\$ 5.50	\$ 1.60
30 x 3 1/2	6.50	1.75
32 x 3 1/2	7.00	1.80
31 x 4	8.00	2.00
32 x 4	8.25	2.00
33 x 4	8.50	2.00
34 x 4	8.75	2.00
33 x 4 1/4	9.50	2.00
34 x 4 1/2	0.00	0.00
35 x 4 1/2	1.00	1.00
36 x 4 1/2	1.50	1.50
35 x 5	2.50	1.50
37 x 5	12.75	3.75

Send your order while prices hold good. State size also whether B. S. or O. I. non-skid or plain tread. Special 5% discount if full cash is sent with order.

PARK TIRE CO. 3540 Ogden Avenue, Dept. 342 Chicago, Ill.



SKINDERVIKEN TRANSMITTER BUTTON

Made in several types for use wherever a transmitter is wanted. Send for instructions and literature No. 1000.

Mechanical Stethoscope

PRICE \$7.50

Improved type for detecting knocks in all running machinery. Test your automobile motor. Descriptive literature sent on request, without obligation.

GENERAL SOUND TRANSMISSION CORP.
Room 507 2 Recter Street New York

THE MIDGET "FIVE-IN-ONE" SLIDE RULE



Is a combination Mannheim, Log-Log, Add and Subtract, Polyphase and Binary Slide Rule. It will instantly add, subtract, multiply and divide any combination involving whole numbers, fractions, decimals and mixed numbers. Gives every possible root and power of every quantity. The graduations are printed on metal, coated with white celluloid and are grease and waterproof. While it is the most versatile calculator ever invented, its operation is simple and easily understood. Diameter 4 inches. Price with 16 page Instruction Book, \$1.50. Less than the carrying case 50c extra. Catalogue Free. Your money back if you are not satisfied.

GILSON SLIDE RULE CO. Niles, Mich.

Stuck on a Chemical or Electrical Problem?

I solve it for Five Dollars

W. STEDMAN RICHARDS

220 Washington St. Boston Mass.

HANDY BINDER for the Electrical Experimenter. Holds and preserves 12 issues, each of which can be inserted or removed at will, without tools. Will keep your magazines perfectly for all time or just preserve them permanently, 65c. Add postage for 2 lbs. Experimenter Pub. Co., inc., 233 Fulton St., N. Y.

and 2.03 calories. To show the suddenness with which changes in this constant occur, its value dropped from 1.95 on March 18, 1920, to 1.87 on March 23, 1920, an interval of only five days. It was on March 22 that there appeared an extensive area of sun-spot disturbance at the center of the sun and most unusual auroral displays and magnetic storms on the earth.

Changes in the intensity of solar radiation affect not only the earth's atmosphere but the atmospheres of other planets as well, as is evident from changes in the brightness of the disks of Jupiter and Saturn and in the appearance of the snow caps and vegetation of Mars, attending changes in the solar constant of radiation. These planets are evidently affected not only by the longer sun-spot period of solar variation but also by the irregular short period variations. For instance photo-electric observations of the brightness of Saturn made by Dr. Guthnick of the Berlin-Babelsberg Observatory compared with observations of the variations in solar radiation made by the Smithsonian Institute at Calama, Chile, show a remarkable correlation, which seems to indicate that the short period solar variations of radiation are caused by the emission of rays of unequal intensities from various regions of the sun, such as would be caused by local changes in the transparency of the solar envelope. These rays of unequal intensities rotate with the sun and affect the atmospheres of the various planets as they come in line with them, one by one.

An effect of the long period solar variation attending the sun-spot cycle was evident in the appearance of the North polar cap of Mars in the apparition of 1913-14, the time of the last sun-spot minimum. The extent of this snow cap was far greater than at any of the ten preceding apparitions, indicating that solar radiation was below normal at that time. Differences in the composition of the atmospheres of the planets as well as the distribution of the land and water surface in the case of Mars would come into the problem of the effect of changes in solar radiation upon each of the planets. These changes would not necessarily be of the same nature as they are on our own planet. A decrease in solar radiation might produce a decrease in Martian temperature and an increase in terrestrial temperature, owing to differences in the atmospheric and surface conditions of the two planets and the nature of the secondary effects produced.

The whole problem of atmospheric effects following changes in solar radiation is so complex that a satisfactory solution can only be expected throughout the continuous and systematic observation of changes in the solar radiation constant made at a number of widely separated stations established in the most cloudless regions of the world; and the recording of the effects of these changes upon atmospheric conditions throughout the world. This promises to be one of the most fruitful and important fields of solar research as well as one that has a practical value for all interested in the prediction of weather changes.

Investigators in this field are seriously handicapped at present by lack of funds for carrying on this work and for this reason there are now but two adequate and suitable stations established for the purpose of observing daily the solar constant of radiation, the stations of the Smithsonian Institute at Calama, Chile, and in the Harqua Hala Mountains of Arizona; there should be ten or twelve such stations situated widely apart in the most cloudless regions of the world.

\$75. A WEEK FOR YOU.

ANYONE CAN BECOME AN EXPERT WIREMAN BY FOLLOWING THE SIMPLE RULES GIVEN IN THIS LATEST EDITION.

YOU NEVER HEARD OF A WIREMAN OUT OF A JOB.

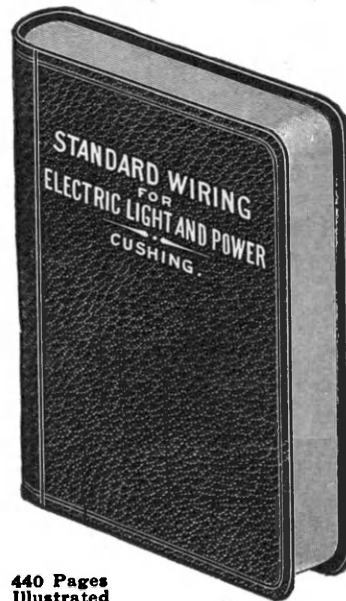

440 Pages Illustrated

The National Authority for 26 Years

The only complete and accurate book on wiring

CONTENTS

The National Electrical Code, with all its new rules, is explained and illustrated. 52 of the latest and simplest tables which show, at a glance, just what size of wire is needed for any kind and size of lighting, motor or heating installation, for any voltage, current and drop desired for any system, Direct Current, Alternating Current, single, two or three-phase. The latest Code Rules on grounding required on all work.

SPECIAL NEW CHAPTERS

How to install and operate generators, motors, storage batteries and every kind of wiring device with diagrams of connections. Illumination, House Wiring, Garage Wiring, Theatre Wiring, Moving Picture House Wiring, Sign Wiring, Marine Wiring, Electric Range and Heater Wiring, Watt-Hour Meter Wiring and complete chapters on inside and outside wiring for every system from a central station to the smallest cottage. 250 Electrical Units and their Definitions and Equivalents. The latest lamp data. Proper symbols to use to indicate outlets, etc., etc. Also a complete directory of the leading manufacturers of officially approved apparatus and supplies necessary for any kind of installation.

Every inspector in this country will approve your wiring job if done in accordance with the simple rules in Standard Wiring.

Leather Cover. Pocket Size. Gilt Edges. Sent Postpaid on Receipt of \$3.00.

H. C. CUSHING, Jr.

8 West 40th Street New York

FREE Use of This Fine Electrical Apparatus



Send for Free Book

A new, fascinating way to learn the highly paid profession of electricity. You study with and work on real laboratory unit boards in your home just as if you were here in this big, world-famous school. A new unit sent every fifth lesson.

Train for Quick Returns

Prepare to enter the fascinating and highly paid field of electricity. Make your successful future a certainty by studying with this renowned school which has specialized in electrical instruction for over 15 years. Over 2300 students were enrolled last year in our resident classes from 46 states and 22 foreign countries. Largest faculty of any similar institution.

Write for "The Short Cut" Book. Send for a copy of "The Short-Cut to the Short Cut." It tells how this wonderfully equipped school is able to bring to you in your own home the easiest and most practical method of instruction in applied electricity. Write today for particulars.

Extension Division

SCHOOL OF ENGINEERING of Milwaukee

Dept. S.I-5 373 Broadway, Milwaukee, Wis.

Learn to Play the Violin IN YOUR OWN HOME



Our method of teaching is so simple, plain and easy that you begin on a piece with your first lesson. In half an hour you can play it. Complete course under personal direction of Prof. A. Hinchcliffe, a musical director and violin teacher of prominence for the past forty years. Low price includes Violin, Bow, Case, Chin Rest, Rosin, Tuning Pipes for all strings, extra set of strings, and complete conservatory course of instruction. Special arrangement for lessons if you have your own instrument. Satisfaction guaranteed.

Send Coupon NOW Get Full Particulars FREE

First Hawaiian Conservatory of Music, Inc. 233 Broadway NEW YORK

I am interested in the VIOLIN. Please send complete information, special offer, etc.

Name.....

Address..... S. & I.-V.

Town and State.....

Write Name and Address Clearly



J. Skinderviken. TRADE MARK

Skinderviken Transmitter Button U. S. and Foreign Patents J. SKINDERVIKEN Inventor and Sole Manufacturer 154 W. Randolph St. Chicago, Ill. \$1.00

ARE YOU BASHFUL, TIMID

Self Conscious, Embarrassed in Company. Let us tell you how you can overcome these troubles and acquire Poise, confidence, assurance and a magnetic personality. Address The Veritas Science Institute, 1400 Broadway, New York, Desk 15.

Dr. Hackensaw's Secrets

By CLEMENT FEZANDIE (Continued from page 17)

"Will all these tubes produce dogs?"
"All on this table—yes! On the next table are my kittens, beyond that guinea-pigs, and the fourth table contains the embryos of rats."

"What's the use of producing more rats artificially? We've got enough of them as it is! Cats and dogs, too? We can get them by the cartload if we want them."

"Of course these are just for experimental purposes. You can see here every step in the growth of the embryo. In the early ones you see a sperm-cell and an egg-cell uniting. In the other tubes you see the fertilized cell growing larger and splitting into two new cells. There is a tube where you see the puppy at the end of a week. I place it by the side of a week old kitten embryo and you cannot perceive any difference between them. It takes an expert to tell whether this week-old embryo will develop into a dog, a horse, a chicken or even a baby."

"Do you mean to tell me," cried Silas Rockett, "that you could grow human babies just as easily as you can these puppies?"

"Just as easily. There is no difference in the process save that it takes nine or ten months to grow a human baby from the egg-cell, whereas the pre-natal period of the dog is only nine weeks."

"After all, though," soliloquized Silas, "what is the use of producing more babies? We have enough and more than enough already and can get plenty more when we want them."

"Perhaps so, altho I think that under some circumstances, as for instance, in France at the present moment, there would be a demand for extra babies to replace the soldiers killed in the war."

"Yes, I understand that," cried Silas Rockett, "but I confess I don't yet see how you expect to make a fortune out of your discovery. Who is going to pay you for all the artificially raised cats and dogs and cats and babies, when any one can get all of them he wants as a free gift?"

At this moment there came a knock on the door.

"Come in," cried the doctor.
The door opened and in stepped Samuel Lyons, the genial head of the Lyons Conglomerated Menageries.

"How do you do, doctor," said he as entered. Have you got those half-dozen trick ponies you promised me?"

"They're all ready for you," replied the doctor. "If you step this way, you can take a look at them. I just took them out of the jars yesterday. They are now in the stable with their foster-mothers."

So saying he led the way into an adjoining stable where eight beautifully marked colts scarcely a day old were lying in a box stall on the straw.

"They're beauties, doctor!" cried the circus proprietor enthusiastically, "and I'll send you that fifty thousand dollar check I promised you, tomorrow. I must go now to see about arranging to send for them."

"Well, Mr. Rockett," said Dr. Hackensaw after Mr. Lyons had left. "Do you understand now where the profits from my invention come from?"

"I can't say that I do. Where is the advantage of raising those colts in glass jars instead of raising them in the ordinary manner?"

SUCCESS

comes to those who employ their idle moments in profitable occupation.

The idler is always complaining about his "hard luck"—a busy person never has time to be anything but prosperous.

If you are ambitious and energetic we will show you how to start a permanent income during your spare time.

The work is light, interesting, dignified, indoor, healthful and extremely remunerative. Best of all, the work you do this year will insure you a permanent income year after year.

No selling, no agency scheme, no canvassing, no mail order, no insurance, no large capital required. No special experience is necessary.

If you have determination to succeed write at once for free particulars regarding our wonderful permanent income plan.

THE BIRD FARM

Lynnhaven Virginia

An Old Fashioned Southern Institution, where Honesty and Fair Dealing are Paramount.

Big "Welworth" 15c

OVER \$1.00 VALUE IN MAGIC NOVELTIES FOR ONLY
One Magic Envelope. Any card, coin, or picture placed in this envelope changes into any other desired article, or vanishes altogether. — 10c
8 Crochet Card Tricks, and sample of special cards. — 10c
One package of invisible ink. Writing cannot be read until heated. — 10c
One Mysocode. A booklet of secret writing systems. Keep your formula, and private correspondence secret, write them in Mysocode. — 10c
13 Curious Love Letters that read two ways. Nothing vulgar, but so rip-roaring funny, they make you laugh. They tickle your joy nerves. — 10c
4 High Grade Formulas for making Parisian Perfume Powder, Eye glass cleaner, and 3 others. All big money makers, and regular price is — \$1.00
Copy of our Big Trick & Novelty Catalog including sample of stage money, formula, etc., and special bargain offers, worth at least — 10c
Return this ad with your order, or mention where you saw it, and everything mentioned above will be sent to you postpaid for only 15c
E. Welworth Co. Box 278, Indianapolis, Ind.

LAW IN YOUR SPARE TIME AT HOME FOR BUSINESS FOR PROFESSION

Study law with only institution which gives same course by correspondence through the entire system as was given for years at resident classes of the College. Business today demands a knowledge of law for those who want success. Big opportunities in the legal profession. We coach you free to pass Bar Examination in any State. Special consultation privileges. Complete 24-volume library (12 books) specially prepared by leading professors and law trained business men. Organized 1910. Low enrollment fee, easy terms. Write for Free Illustrated Book.

HAMILTON COLLEGE of LAW, 405 Morton Bldg., Chicago

MUSIC TAUGHT FREE

You can learn music like this quickly. In Your Home. Write today for our booklet. It tells how to learn to play Piano, Organ, Violin, Mandolin, Guitar, Banjo, etc. Beginners or advanced pupils. American School of Music, 57 Lakeside Bldg., Chicago

ALL MAKES

Underwoods, Monarchs, Remingtons, L. C. Smiths, Oliviers, Royals, Coronas AT REDUCED PRICES. \$20.00 Prices as low as....

Write for our Catalog No. 15 BERAN TYPEWRITER CO. Dept. 21, 58 W. Washington Street, Chicago



Wonderful, new device, guides your hand; corrects your writing in few days. Big improvement in three hours. No failures. Complete outline FREE. Write C. J. Ozment, Dept. 44 St. Louis, Mo.

TUBERCULOSIS

I control a patented process to cure this dreaded plague. It has the endorsement of leading physicians and has been tested thoroughly with remarkable results. Will sell half or whole interest. To anyone desiring to invest in an enterprise that not only will prove a boon to humanity, but of great personal profit. I will send full particulars. Address BOX 10, SCIENCE & INVENTION

25c to \$4.00 At Your Stationer's Accept No Imitation

ROBINSON REMINDER TEAR OUT WHEN ATTENDED TO

Each memo a perforated coupon which, when out, LEAVING LIVE NOTES ONLY. No searching thru obsolete notes. Everything ready for instant reference. Pocket in cover.

Reminder with Extra Filler	Size B 3 x 5 in.	Size A 3 1/4 x 7 in.	Ladies' Size 2 3/4 x 3 3/4 in.	With Pencil and Extra Filler
Robinson Leather	\$1.00	\$1.75	\$1.25	\$1.25
Cross Grain	1.50	2.50	1.50	1.50
Cowhide	2.25	3.00	1.75	1.75
Calf skin	3.50	3.25	2.00	2.00
Genuine Morocco	2.75	3.75	2.25	2.25
Genuine Seal	4.00	5.00	---	---
Patent Leather	---	---	1.75	1.75
Cloth (no extra filler)	.25	.50	---	---
Imitation Leather	.75	1.00	---	1.00

Extra Filler Name in gold on cover, 25c extra

Sizes 3 x 5 in. (4 coupons to page) \$.75 per doz.
 Size 3 1/2 x 7 in. (6 coupons to page) 1.00 per doz.
 Size 2 3/4 x 3 3/4 in. (3 coupons to page) .70 per doz.
 Robinson Desk Pad: 4 x 6 in., \$1.00; 5 x 8 in., \$1.50

Write for your stationer's price from us. Stationers, write to Robinson Mfg. Co., 131 Elm St., Westfield, Mass.

Kleradesk

Saves time—clears your desk. Sorts, classifies and distributes your correspondence, papers, memos, etc. Occupies much less space than wire baskets. No more shuffling through piles of papers many times daily.

A Steel Sectional Device

Each compartment a separate section. Any number of compartments for flat or vertical filing can be added as required. Width of each compartment is adjustable, one to ten inches. Indexed front and back. Green, oak or mahogany finish.

Write for free, instructive, illustrated folder. "How to Get Greater Desk Efficiency."

Ross-Gould 165 N. 10 St. St. Louis.

FREE BOOK-LAW

Send for This Free 118-Page Book

It tells how you can gain a thorough knowledge of law in your spare time at home as 40,000 others are now doing. Many high salaried positions in business open to law-trained men. Also splendid opportunities in the practice of law. Our free book shows how you can train under the guidance of Ex-Pres. Taft and 30 other famous legal authorities. Diploma granted. Write: **Michigan Institute, Dept. 1255, 4752 Grand Blvd., Chicago, Ill.**

LEARN ENGINEERING

Electrical and Mechanical Engineers receive fabulous salaries. Thousands wanted. 3 months to 2 years Practical. Technical training under experts. Not a trade school but a Practical-Technical College teaching electricity, steam, gas, auto-electric, armature winding, drafting. Extensive laboratory and shop equipment. Degrees awarded. Day and night sessions. Enroll any time. Don't judge us by size of ad. Write for free catalog. **FINLAY ENGINEERING COLLEGE, 1003 Indiana Avenue, Kansas City, Mo.**

Big Band Catalog Sent FREE

Anything you need for the band—single instrument or complete equipment. Used by Army and Navy. Send for big catalog. Liberally illustrated. Italy descriptive. Meet what instrument interests you. Free trial. Easy payments. Sold by leading music dealers everywhere.

LYON & HEALY, 64-91 Jackson Blvd., Chicago

STAMMER NO MORE

Kill the fear of stammering. Re-education the key. The widely famed Hatfield Method fully outlined in an accurate, dependable, worthwhile book—"HOW TO STOP STAMMERING." It has inspired thousands. Free copy today. **THE HATFIELD INSTITUTE, 169 N. Dearborn, Chicago, Ill.**

"In the ordinary manner," replied the doctor, "one mare raises one colt a year. Now a mare's ovaries contain hundreds of egg-cells many more than she could ever raise colts if she lived to be as old as Methuselah. These egg cells ripen quickly in my culture fluid. So by buying prize stock—stallions, mares, bulls and cows worth tens of thousands of dollars apiece, I can raise hundreds of valuable animals from each pair in a year instead of having to wait hundreds of years for them, as would be the case if I followed the natural method—to say nothing of the risk of losing the parents by death or accident."

"What about the expense?"

"The expense is not so great as you might think. My culture fluid is manufactured principally from odds and ends from the slaughter-houses, which I boil into a kind of rich bouillon. When I begin making it in large quantities the cost will be very reasonable. Even at the present cost, I find I can manufacture leather very profitably."

"Leather?" exclaimed Silas Rockett.

"Yes—you are no doubt aware that the leather from unborn calves is very valuable and is much used where a very high grade of leather is desired. Well, in my laboratory here I can manufacture unborn calves by the thousand at a very handsome profit. Furs, too, will be very remunerative. There is no limit to the number of seals, minks, ermine and other valuable fur-bearing animals that I can raise by my method from a single pair of parents. From hides and furs alone I can easily make a billion dollars net profit within a couple of years!"

Doctor Hackensaw paused a moment, as if in doubt and then added, "I shall now show you something rather curious. I do not expect any financial returns from it, but it is interesting as a scientific curiosity. It is what I call a *dog-cat*." And with these words the doctor went to a covered cage, and drew therefrom a curious creature,—half cat, half dog. It had the head of a dog but the body and claws of a cat, and arched its back with pleasure as the doctor patted it.

"You see," explained Doctor Hackensaw, "this creature is a cross between a dog and a cat. With my method of artificial reproduction, it is the easiest matter in the world to cross two animals that are not too far apart in the scale of nature. For instance my dog-cat was made by the union of the egg-cell of a female dog with the sperm-cell from a tom-cat. You will observe that certain characteristics of one animal seem more powerful than those of the other parent. Thus, the *head* of the dog is here prepotent over that of the cat, while the *body* of the cat is prepotent over that of the dog."

Returning the animal to its cage, the doctor proceeded to a table where were racks of test-tubes and rows of glass jars of different sizes.

"You will observe," continued the doctor, "that most of my experiments are made in *VITRO*,—that is to say in glass containers. This table contains hybrids of all kinds. There is my favorite corner in the laboratory, for, while most of my experiments have been unsuccessful, I have succeeded in making some crosses, that not only have never been made before, but that it would be impossible to make otherwise. There, for example, is a cross between a rat and a pig. You see, the union has been partially successful for my embryo rat-pig is a week old, but it is dying and the creature will never be fully formed. I have made numerous attempts to cross a dog or other quad-

Your Choice 75c a Week



No matter what your occupation, one of the home study sets listed below will quickly fit you for a better job and bigger pay. Any set you select will be sent for seven days' examination, and if you decide to buy you may pay the rock-bottom price at the rate of only 75c a week. But you must act now to get the consulting membership along with the set free.

These books are the work of recognized authorities. They are written in plain, easily understood language by recognized authorities, and contain hundreds of photographs, diagrams, tables, etc., that make difficult points as simple as A-B-C. Handsomely and durably bound in genuine American Morocco, and stamped in gold.

Pay-Raising Books At Greatly Reduced Prices

- Accountancy and Business Management, 7 vol., 2700 pages, 1000 pictures, was \$52.50.....Now \$29.80
- Carpentry and Contracting, 5 volumes, 2138 pages, 1000 pictures. Was \$37.50.....Now 24.80
- Civil Engineering, 9 volumes, 3900 pages, 3000 pictures. Was \$67.50.....Now 39.80
- Electrical Engineering, 8 volumes, 4100 pages, 3300 pictures. Was \$60.00.....Now 34.80
- Automobile Engineering, 6 volumes, 2600 pages, 2000 pictures. Was \$45.00.....Now 24.80
- Machine Shop Practice, 6 volumes, 2300 pages, 2500 pictures. Was \$45.00.....Now 24.80
- Steam and Gas Engineering, 7 volumes, 3300 pages, 2500 pictures. Was \$52.50.....Now 29.80
- Law and Practice (with reading course), 12 volumes, 6000 pages, illustrated. Was \$97.50.....Now 49.80
- Fire Prevention and Insurance, 4 vols., 1500 pages, 600 pictures. Was \$30.00.....Now 19.80
- Telephony and Telegraphy, 4 volumes, 1728 pages, 2000 pictures. Was \$30.00.....Now 19.80
- Sanitation, Heating and Ventilating, 4 volumes, 1454 pages, 1400 pictures. Was \$30.00.....Now 18.80
- Drawing, 4 volumes, 1578 pages, 1000 pictures, blue-prints, etc. Was \$30.00.....Now 19.80

Send No Money Shipped for 7 Days' Trial

Yes, we'll gladly ship any set right to your home or office upon your simple request. Pay only shipping charges when the books arrive. Don't send a penny until after you have used them seven days, then remit only \$2.80 or return them at our expense. Pay balance at the rate of \$3.00 a month—75c a week.

Act now—while these splendid books are being offered at 20% to 60% less than regular prices. This offer is open to every person within the boundaries of the U. S. and Canada. Grasp your opportunity—all in and mail the coupon NOW.

American Technical Society, Dept. X-255, Chicago

American Technical Society, Dept. X-255, Chicago, U.S.A.

Please send me set of.....

for 7 DAYS' examination, shipping charges collect I will examine the books thoroughly and, if satisfied, will send \$2.80 within 7 days and \$3 each month, until I have paid the special price of.....

If I decide not to keep the books, I will notify you at once and you will be subject to your order. Title not to pass to me until the set is fully paid for.

Name.....

Address.....

Reference.....

Genuine



Aspirin

Always say "Bayer"

Unless you see the name "Bayer" on tablets, you are not getting genuine Aspirin prescribed by physicians for 21 years and proved safe by millions. Directions in package.

Aspirin is the trade mark of Bayer Manufacture of Monoaceticacidester of Salicylicacid.



Why Many Men are Old at 40

Perhaps the most common cause is the disturbed condition of an important gland. Even men of iron constitution are not exempt from this amazingly common irregularity. We have for limited distribution, an ethically accurate, educational and interesting.

FREE BOOK

Its message may prove of unsuspected value to you. It explains how a disturbed condition of this vital gland may cause sciatica, headache, painful and tender feet, interrupted sleep and other extremely uncomfortable and often serious conditions. It tells of Thermanalid, a simple means by which the essential of a new hygienic principle, done into convenient form corrects this prostate gland condition and its attendant health faults without medicine, massage, or knife. The records of its success for five years is incontrovertible. The book is free. Simply address

THE ELECTRO THERMAL COMPANY
81 H Kirk Building, Steubenville, Ohio



PIGEONS PAY

Build their own nests. Feed their own young. Very profitable business. Get your start with a few good pairs. Write today for 1921 Circular. Pigeon Supply House, Hanover, Pa.

GET BIG MUSCLES!

YOU can have a SUPERB MUSCULAR DEVELOPMENT and PERECT HEALTH. My illustrated book, telling how I evolved Master System of Strength Development, sent FREE for 4c. postage. Prof. M. Magee James, 1187 James Institute, Philadelphia, Penna.

PIMPLES

Blackheads—Acne Eruptions

Now Are Easily Removed at Home at a Small Cost!

Banish those unsightly blemishes easily and quickly by using "CLEAR-TONE"—a simple home treatment that has cured chronic cases of long years standing. Use like toilet water. Leaves the skin clear, smooth and without a blemish. Has made many friends with both men and women. Elegant for men after shaving. If you have Pimples, Blackheads, Acne Eruptions on the face or body, Enlarged Pores, Oily or Shiny Skin—never mind how bad—"CLEAR-TONE" has cured the worst cases I ever saw. FREE—simply send name today for FREE Booklet, "A CLEAR-TONE SKIN," telling how I cured myself after being afflicted for 16 years. And I know every embarrassment one has to endure with a bad complexion. \$1,000.00 Cold Cash says I can clear your skin of the above blemishes.

E. S. GIVENS 168 Chemical Building KANSAS CITY, MO.

rupted with a chicken, but so far have been altogether unsuccessful, although in one or two cases the egg-cell and sperm-cell seemed to unite and grow a little. In spite of this failure I tried even wilder experiments—I tried to cross a dog with an oyster and a cat with a rose!

"With a rose?" exclaimed Silas Rockett. "Why, I didn't know that flowers had any sex."

"Yes indeed. Almost all flowers are hermaphrodites—that is to say they bear male and female organs in the same flower. The yellow dust or pollen in a rose is the male element that I endeavored to cross with the egg-cell of a cat. Then too, I tried to fertilize the ovules or egg-cells of the rose with sperm-cells from a cat, but without the slightest success."

"What good would it do, if you could cross a cat with a rose?"

"That is a thing no one can know. We can be sure of one thing however, that some crosses will one day be made that will give mankind new species of animals or plants or plant-animals, that will be of the highest value. I myself hope to succeed in producing a plant more useful than wheat, corn, or the potato, and an animal more useful than any of our domestic animals. I believe that some day we shall have a horse that will give milk like a cow, bear wool like a sheep, lay eggs like a chicken, bark like a dog and be as good to eat as a hog. There's a combination that's worth trying for. A farmer can have all his domestic animals united into one, and have but a single individual to feed, and attend to. But, of course years of experience will be required before we can hope to achieve any such result. Yet there is no limit to what we may hope to effect by judicious crossing and careful selection."

"Well doctor, thank you very much. I have had a most enjoyable visit, and have secured material enough for a first class article. I shall now have to go."

"One moment," said the doctor, "I have still something of interest to show you in the stable. "You haven't seen my cows yet."

Silas Rockett hesitated and looked at his watch, but there was something in Doctor Hackensaw's face that promised new wonders.

"Very well, doctor," said he, "let us go and see the cows."

"I haven't many cows," observed the doctor apologetically, "and they're all scrubs. But for my purpose there is no use in paying high prices for pure bred cattle. Any strong healthy cow does as well as the most expensive registered stock."

"I don't understand you," said Silas Rockett, puzzled. "I thought you raised only the very best pedigreed stock."

"So I do. That is—I obtain my egg-cells and sperm-cells from the very best stock in the United States or Europe. But often, after the fertilization of the ovum is complete in my test tube, I in-

To Make Rich Red Blood

Revitalize your worn-out exhausted nerves and increase your strength and endurance

take Organic Iron; not metallic iron which people usually take, but pure organic iron—Nuxated Iron—which is like the iron in your blood and like the iron in spinach, lentils and apples. One dose of Nuxated Iron is estimated to be approximately equivalent (in organic iron content) to eating one-half quart of spinach, one quart of green vegetables or half a dozen apples. It is like taking extract of beef instead of eating pounds of meat. Nuxated Iron is partially predigested and ready for almost immediate absorption and assimilation by the blood, while metallic iron is iron just as it comes from the action of strong acids on small pieces of iron filings.

Over 4,000,000 people annually are using Nuxated Iron. It will not injure the teeth nor disturb the stomach. A few doses will often commence to enrich your blood. Your money will be refunded by the manufacturers if you do not obtain satisfactory results.

Beware of substitutes. Always insist on having genuine organic iron—Nuxated Iron. Look for the letters N. I. on every tablet. Sold by all druggists.

NUXATED IRON
For Red Blood, Strength and Endurance

Deafness



Perfect hearing is now being restored in every condition of deafness or defective hearing from causes such as Catarrhal Deafness, Relaxed or Sunken Drums, Thickened Drums, Roaring and Hissing Sounds, Perforated, Wholly or Partially Destroyed Drums, Discharge from Ears, etc.

Wilson Common-Sense Ear Drums
"Little Wireless Phones for the Ears" require no medicine but effectively replace what is lacking or defective in the natural ear drums. They are simple devices, which the wearer easily fits into the ears where they are invisible. Soft, safe and comfortable. Write today for our 168 page FREE book on DEAFNESS, giving you full particulars and testimonials.

WILSON EAR DRUM CO., Incorporated
677 Inter-Southern Bldg. LOUISVILLE, KY.

Don't Wear a Truss

We Guarantee Your Comfort



with every Brooks' Appliance. New discovery. Wonderful. No obnoxious springs or pads. Automatic Air Cushions. Binds and draws the broken parts together as you would a broken limb. No salves. No plasters. No ties. Durable, cheap. Sent on trial to prove it. Full information and booklet free.

C. E. BROOKS
203 F State St. Marshall, Mich.

DEAFNESS' IS MISERY
I know because I was Deaf and had Head Noises for over 30 years. My invisible Antiseptic Ear Drums restored my hearing and stopped Head Noises, and will do it for you. They are Tiny Megaphones. Cannot be seen when worn. Effective when Deafness is caused by Catarrh or by Perforated, Partially or Wholly Destroyed Natural Drums. Easy to put in, easy to take out. Are "Unseen Comforts". Inexpensive. Write for Booklet and my sworn statement of how I recovered my hearing.

A. O. LEONARD
Suite 369, 70 5th Avenue -- New York City

PANDICULATE FOR HEALTH

BE WELL, YOUNG, STRONG. Booklet FREE. Fifteen glorious minutes on Pandiculate better than two hours in gymnasium. Refreshes, rejuvenates. Helps retain youth, energy, vigor, vim. Wonderful results. Doctors recommend it. No electricity—no discomfort; delightfully restful. Write today. **PANDICULATOR CO., 332 Prospect Bldg., Cleveland, O.**

MEN

Intensely interesting booklet free. *Wonderful results.*
The Gyde Co., Dept. 13,
Washington, D. C.

WARNER'S "INFALLIBLE" AUTOMATIC



Get a Warner "Infallible" Automatic and teach the women how to plug the bull's eye. Target shooting is intense, exciting sport. Excellent training for nerves and eyes. Teaches self-reliance, confidence and familiarity with weapons. What a Shooter Says: "Your 'Infallible' Automatic Pistol is all that you claim and more. I put seven shots in bull's eye one inch in diameter at distance of twenty-five feet with the pistol. The accuracy of this arm is unsurpassed by any regardless of price." C. S. Hoffman, 187 Oakwood Avenue, Orange, N. J.

FREE LESSON OFFER
An authority has prepared for us, a set of six lessons on the Art of Pistol Marksmanship. These lessons are of marvelous value in the use and care of a Warner "Infallible" Automatic. Write today for illustrated circular and terms of Free Lesson Offer.

KIRTLAND BROTHERS & CO., INC.
86 Chambers St. (DEPT. E.E.) New York



DEPENDABLE KNAPP LEADER
ELECTRIC SPECIALTIES

The Big Power Motor for Boys \$4.50

A compact, highly efficient reversible motor—perfect in every detail. The reducing gear, easily adjusted, transforms the high speed to more power at slower speed. The reversing switch is positive in action, and operates either as a starting switch or to reverse the direction of the motor at will. This motor is guaranteed by us to be exactly as represented.



AT ALL LIVE DEALERS
Insist on your dealer showing you the KNAPP line—KNAPP goods are best. If your dealer cannot supply you, order direct. Send for FREE illustrated catalogue showing a complete line of Electrical Motors and Novelties.
KNAPP ELECTRIC & NOVELTY CO.
523 West 51st Street, N. Y. City

LEARN WATCH REPAIRING

You can learn by our modern and original system of instruction every part of the Watch Repairing Trade at home as good or better than at a shop. You can earn money while learning and will pay no tuition or start in completing our course of instruction. Good watch repairers are always in demand and earn from \$30 to \$65 per week. For particulars apply to the

MILWAUKEE SCHOOL OF WATCH REPAIRING, 160 Mason St., MILWAUKEE, WIS.

Handwriting Tells You Secrets

Be successful. Find out what holds you back. Send us an ink specimen of your handwriting and \$1.00. Our expert Graphologists will tell you your faults, virtues, talents, etc. Your \$1.00 back if you are not satisfied.
ROBERT R. ROSS, 110 West 40th St., N. Y.

5 Master Keys

The most wonderful and only set of keys of its kind. They open and test thousands of different locks. They have satisfied thousands of purchasers, and are used and recommended by locksmiths, janitors, detectives, and other great key users. They are unequalled as a useful, convenient, and household article. Send \$1.00 for set and novel key chain.
MASTER KEY CO., 42 Manhattan Bldg., MILWAUKEE, WIS.

"BOW LEGS and KNOCK-KNEES" UNSIGHTLY

Send for booklet showing photos of self with and without THE PERFECT LEG FORMS.
PERFECT SALES CO.
140 N. Mayfield Ave., Dept. 50, Chicago, Ill.

roduce the egg into one of these cows, with the result that I obtain a pure-bred calf from a scrub cow. This calf you see here is worth ten thousand dollars. It comes from a celebrated bull and a prize cow. Yet the egg grew and developed and the calf was born in this scrub cow you see here, which I bought for only fifty dollars. A ten thousand dollar calf from a fifty dollar cow is what I secure by my method."

"But is the calf as good as if it had been borne by its pure bred mother."
"Precisely as good. Once the egg is fertilized, the characteristics of the calf are fixt, and the nourishment it receives in the cow will no more change it than you could change a horse into a dog by feeding him on meat. To prove it you need only look into the next stall, where you will see another cow with her young."

Silas Rockett peered into the stall long and earnestly.
"There is nothing there," said he, "except a young puppy."

"Yes," said Dr. Hackensaw. "That's a full blooded Saint Bernard, and yet the cow you see there was his mother!"
"Impossible!"

"Yes, or rather the cow was his foster-mother. The pup's real father and mother were thoroughbred Saint Bernard dogs, but after fertilizing the egg-cells in my test-tubes I introduced the egg into this cow, so the pup was really born from a cow."

"But how can a dog that lives on meat, grow inside a cow that lives on grass."

"Just as easily as a puppy can be raised on cow's milk. What worried me was not the question of food, but the difference in the period of gestation. A calf lives nine months inside its mother, while a puppy lives only nine weeks. But the cow solved the problem by giving birth to the pup after nine weeks."

"And now, Mr. Rockett," continued the doctor, "if you will kindly step into the house, I will show you the result of my latest experiment in this line."

So saying the worthy doctor led the way into a sun-parlor, and gently drawing aside the curtain from a crib, he displayed to the astonished gaze of the visitor the countenance of a three weeks' old girl baby.

"There, Mr. Rockett," said he. "There is a baby that was born from one of my cows. And yet you couldn't tell her from any other baby except that she is more perfect in every respect. I wished to adopt a child, but I resolved to have one that would be as near perfection as possible. So I hunted thru the United States and Europe until I found just what I wanted—a young man who was an almost perfect specimen of physical manhood, with a fine intellect as well as a healthy body. He is the father of my little girl here. The mother was a beautiful and refined young girl with a figure that would make a sculptor rave. The father and mother have never seen each other—he never left the United States and she never left Europe. I hesitated long whether to raise the egg-cell in one of my glass jars or in a cow, but finally decided on the cow. And here is the result—a baby girl that promises to be perfection itself when she grows up."

"Yes, Mr. Rockett, I have solved our eugenic problem. By means of my discovery the human race could be perfected in the course of a very few years. By selecting the finest types of manhood and womanhood for parents, I could grow artificially hundreds of thousands of almost perfect children. And in a few generations mankind would scarcely recognize itself!"

Weaklings Are Counted OUT!



STRONGFORT
The Perfect Man

Nobody wants you socially or in business when you are a physical weakling and look twice as badly as you feel.

Get Rid of Your Handicaps
You can be healthy and successful—you can free yourself from the ailments and defects that are holding you down and that sooner or later will cause you to lose your friends and your job. You can build yourself up—clear your befuddled brain—develop your muscles, purify and enrich your blood, strengthen and correct every organ and function and fit yourself for the Joys of Life, if you will only look the facts squarely in the face and GET BUSY with

STRONGFORTISM

The Modern Science of Health Promotion
Strongfortism—Nature's First Assistant—is the result of a lifetime's study, research and experience in physical and health building. First I applied these scientific truths to my own person and won the world's award as the strongest man and most perfect specimen of physical and health attainment. These are the same wonderfully effective principles that I will apply in your case. No matter what your condition is, or what caused it, STRONGFORTISM can aid Nature in restoring your body and brain to normal health, strength and vigor. I guarantee it

Send for My Free Book

The fundamental elements of Health, Strength and Success in every phase of existence are contained in my free book, "Promotion and Conservation of Health, Strength and Mental Energy." It is the most interesting and instructive book that you ever read. It will tell you how you can build up perfect health and strength and fit yourself for a position in the front line, with the winners. Asking for the book does not obligate you in any way. Just send a ten cent piece (one dime) to help cover the cost of packing, etc. It's a success-maker—a man builder and a life saver. Send for my book *Right Now*.

LIONEL STRONGFORT

Physical and Health Specialist
Department 303 Newark, New Jersey
Founded 1896

----- Cut Out and Mail This Coupon -----

FREE CONSULTATION COUPON
Mr. Lionel Strongfort, Dept. 303, Newark, N. J.—Please send me your book, "PROMOTION AND CONSERVATION OF HEALTH, STRENGTH AND MENTAL ENERGY," for postage of which I enclose a 10c piece (one dime). I have marked (X) before the subject in which I am interested.

- | | | |
|------------------|--------------------|------------------------|
| Colds | Increased | Vital Depletion |
| Catarrh | Height | Impotency |
| Asthma | Pimples | Falling Hair |
| Hay Fever | Blackheads | Weak Eyes |
| Obesity | Insomnia | Gastritis |
| Headache | Short Wind | Heart Weakness |
| Thinness | Flat Feet | Poor Circulation |
| Rupture | Stomach | Disorders |
| Lumbago | Disorders | Skin Disorders |
| Neuritis | Constipation | Despondency |
| Neuralgia | Biliousness | Round Shoulders |
| Flat Chest | Torpid Liver | Lung Trouble |
| Deformity | Indigestion | Stoop Shoulders |
| (Describe) | Nervousness | Muscular |
| Successful | Poor Memory | Development |
| Marriage | Rheumatism | Great Strength |

Name.....
Age.....Occupation.....
Street.....
City.....State.....

Opportunity Ad-lets

YOU will find many remarkable opportunities and real bargains in these columns. It will pay you to read and investigate the offerings made every month by reliable firms, dealers and amateurs from all over the country. No matter what you may be seeking, whether specialties, automobile accessories, the opportunity to make money, or anything else, you will find listed here the best and most attractive specials of the month.

Advertisements in this section twelve cents a word for each insertion. Name and address must be included at the above rate. Cash should accompany all classified advertisements unless placed by an accredited advertising agency. No advertisement for less than 10 words accepted.

Ten per cent. discount for 6 issues, 20 per cent. discount for 12 issues. Objectionable or misleading advertisements not accepted. Advertisements for the July issue must reach us not later than May 22.

The Circulation of Science and Invention is over 135,000 and climbing every month

EXPERIMENTER PUBLISHING CO., INC., 236 Fulton Street, New York City, N. Y.

Aeronautics

Boys fly this model aeroplane. Circular free. Aero Shop, 3050 Hurlbut Ave., Detroit, Mich.

Our new 1921 Large Aeronautical Supply Catalog now off the press. Late ideas and low prices. Send 15c. Our Ford and Motorcycle Airplane pamphlets describe the most complete little machines on the market. Propeller Catalog also. 4c. each. Heath Aeroplane Co., Chicago.

Aviation

Learn to Fly. America's oldest and most reliable Flying School. Complete Ground and Flying Instruction. We guarantee to make you an expert Pilot. Third Successful Season. Dozens of satisfied graduates. Classes begin the first of each month. Write now for Literature and Catalogue. The Ralph C. Diggins Co., 140 N. Dearborn St., Chicago, Ill.

Auto Accessories

How to make automobile storage battery plates. \$1.00 postpaid. H. Deckelman, 7118 Nashville Ave., St. Louis, Mo.

Autoists 'Saviorgas' easily mixed. Saves gas. Decarbonizer. Recipe 10c. coin. Hawthorne Co., Roslyn, Wash.

Auto Motors Supplies. Buick, Michigan, Stoddard-Dayton, E. M. F. Cadillac, Overland, Continental and Buda Motors. All Types, \$50.00 each and up. New Dixie Magneto \$20.00. Splittorf High Tension Magneto \$10.00. Kellogg Pumps \$3.50. Auto-Lite generators, new, \$10.00. Air Gauges \$.65. Remy Ignition Coils, new, \$3.00. Electric and Gas Headlamps, coils, distributor heads, air compressors, etc. Write for catalog. Motor Sales, Dept. 12, West End, Pittsburgh, Pa.

Tire Agents. Exclusive representatives to use and sell the new Mellinger Extra-Ply Tires. (No seconds.) Guaranteed Bond 8,000 Miles. Wholesale Prices. Sample sections furnished. Mellinger Tire Co., 980 Oak, Kansas City, Missouri.

Storage Batteries for Automobiles. We furnish all parts and Moulds for making them. Sample Plate 40c. Foreign Countries 50c. Windsor Specialty Co., 5419 Windsor Ave., Chicago, Ill.

Exclusive Agency. Greatest Ford Accessory ever invented. An Automatic auxiliary air valve using steam vapor from off the warm water in radiator. Easily demonstrated and installed. Averages 25% saving of gasoline and eliminates all carbon trouble. Money back guarantee. Write for particulars. Automatic Valve Engineering Co., 89 Clark, Brooklyn, N. Y.

Fords start easy in cold weather. Will run 34 miles per gallon on cheapest gasoline or half kerosene, using our 1921 carburetors. Increased power; styles for all motors; can attach them yourself. Big profits to agents; money back guarantee; 30 days trial. Air Friction Carburetor Co., 1511 Madison St., Dayton, Ohio.

Old Worn out Casings will give 3 to 5 thousand miles more service with Insyde Tyres. Just slip inside casing before replacing tube. No tools needed. Will not heat or pinch. Positively prevent punctures and blow-outs. Guaranteed double tire mileage. Any tire. Low priced. Agents wanted in every county. American Accessories Co., B-884, Cincinnati, Ohio.

Wanted Platinum Magneto Points, old or new. We pay full value, mail or express. Packages returned if our offer is not satisfactory. Highest cash prices paid for old Gold, Silver, Watches, Platinum, Crowns and Bridges, Diamonds, War Bonds and Stamps. United States Smelting Works. (The Old Reliable) Dept. 13, Chicago, Ill.

Motorcycles, Bicycles

Don't Buy a Bicycle Motor Attachment until you get our catalogue and prices. Shaw Mfg. Co., Dept. 1605, Galesburg, Kans.

Used Parts for all Motorcycles. Schuck Cycle Co., 1922 Westlake, Seattle, Wash.

Motors, Engines and Dynamos

Special Garage Motors. Manufactured by the General Electric Co. 1 H.P. \$78.50, 2 H.P. \$110.00, 3 H.P. \$128.50, 5 H.P. \$166.50. All sizes both single and Polyphase Motors for immediate delivery. Special charging generators, all voltages. Write for catalog. Motor Sales, Dept. 12, West End, Pittsburgh, Pa.

Electric Motor Construction. Learn how. Complete outfit, instructions, blue prints \$2.00. Blue Prints only 25c. A. F. Cassell, Box 355, Oradell, N. J.

Machinery & Tools

Complete Machines or Parts manufactured. Tools and Special Machinery designed and built. Patents perfected. E. Bieber, Reading, Pa.

Here's an advertiser who has had such good results he wants to use display!

March 25, 1921.

Experimenter Publishing Company,
233 Fulton Street,
New York, N. Y.

Dear Sirs:

Enclosed find Money Order for Six dollars and the copy of an adv. for the May number.

You will notice that although the adv. amounts to Three dollars I am sending Six, the reason being that I want you to make a little display.

Although I have received some replies to my advs. as now appearing I wish to get a line upon the class of your subscribers that I may make a yearly contract with you for one half page.

It seems that there is a considerable demand for the services of an expert chemist and the character of the replies I have received prove that your list are high class people.

Thanking you in advance, I am
Yours respectfully,
W. STEDMAN RICHARDS

Duplicating Devices

"Modern" Duplicator. A business getter; \$2.25 up. 50 to 75 copies from pen, pencil, typewriter. No glue or gelatine. 40,000 firms use "Modern" Duplicator. From dealers or on 10 days trial from us. You need one. Write for free booklet. B. J. Durkin, Reeves & Co., Pittsburgh, Pa.

For Advertisers

Advertising. We will prepare and insert your advertisement in 100 busy newspapers, proved insertions, \$10. Catalog special offers many newspapers, magazines, free. Scott & Scott Adv. Agency, Candler Bldg., New York.

Business is always good when you use Jacobus literature. Letters \$3.50. Jacobus Service, 41 Bruen, Irvington, N. J.

Salesmen Wanted

Salesmen. Earn \$3,500 to \$10,000 a year. City or Traveling. Experience unnecessary. Quickly qualify through our amazing system. Free employment service to members. Send for Salesmanship book, list of lines and full particulars. Nat. Salesmen's Training Ass'n, Dept. 158E, Chicago, Ill.

Agents Wanted

Agents. 25c. nonsplashing filter find free; write for sample. Easy seller. Returns big. Faucet-Fit Manufacturers, X17, Malden, Mass.

Agents. Get particulars; 12,000 word copy, Spare Time Money Makers 50c. Catalog Free. American Highmark Mfg. Co., Mesaba Bldg., Duluth, Minn.

Agents. Sell our accident and sickness policies in your spare time. Pay \$5,000 death, \$25 weekly benefit. Premium \$10 yearly. Permanent income from renewals. Easy seller. Liberal commissions. Insurance Co., Dept. N-6, Newark, N. J.

Perfume Blocks sell everywhere. One Block, costing fifty cents, perfumes an entire room for two months. 100% profit. Territory protection. International Chemical Co., Dept. A, Cleveland, Ohio.

Agents. Our soap and toilet article plan is a wonder; get our free sample case offer. Ho-Ro Co., 138 Locust, St. Louis.

Are you out of work or have you any spare time? Turn your spare time into dollars. My universal Burglar, fire, and water alarm sells on sight, can be attached in a minute to doors, windows, mail boxes, water tanks or any place where an alarm is required. Something new sensational. Only one agent in each town. Sample and instructions one dollar. Master Alarm, 111 N. Jefferson St., Dayton, Ohio.

Newest Thing Out. Lithogram initials for automobiles, motorcycles, canoes, golf sticks, tennis racquets, etc. Anyone can apply them in a jiffy. Sell to everybody. Set costs 15c.; brings \$1.50. Fast sales and big daily profits for agents. Write for catalog. Lithogram Company, Desk 19, East Orange, N. J.

Agents. \$60 to \$200 a week. Free Samples. Gold Sign Letters for Store and Office windows. Anyone can do it. Big demand. Liberal offer to general agents. Metallic Letter Co., 433Z N. Clark St., Chicago, Ill.

Agents. Big returns, fast office seller; particulars and samples free. One Dip Pen Co., 12 Daily Record Bldg., Baltimore, Md.

Beginners' Complete Mail Order System. EX. Box 1005, Atlantic City.

Agents. 200% profit. Wonderful little article; something new; sells like wildfire; carry in pocket; write at once for Free Sample. Albert Mills, Gen. Mgr., 4920 American Bldg., Cincinnati, Ohio.

Big money and fast sales. Every owner buys gold initials for his auto. You charge \$1.50; make \$1.35. Ten orders daily easy. Write for particulars and free samples. American Monogram Co., Dept. 71, East Orange, N. J.

Signs for Stores and Offices. Entirely new. \$50 week easily made. Assorted working samples 25c. Chicago Sign System, E. 326 River St., Chicago, Ill.

Agents. Mail Order Buyers. Send now for our 1921 list of specials. Rare Books, Novelties. Enclose postage. Gordon's Specialty House, P. O. Box 1323, San Francisco, California.

Electrical Supplies & Appliances

To Order. Metal Articles, models, tools, patterns, experimenting, manufacturing, inventions developed. Cleveland Specialty & Manufacturing Co., Cleveland, So. Brooklyn, Ohio.

Electricians. Wiremen, Linemen, send your name and address for descriptive literature of our Modern Blue Print Chart Method of Electrical Wiring. Over 350 practical diagrams. Electrical Wiring Diagram Co., Box C-173, Altoona, Pa.

'Tenshun! Students, Amateurs, Wiremen. Twelve best prints for quarter. Smith, Box 103, Collinwood Station, Cleveland, Ohio.

Electricians. All transformer connections for 1, 2 and 3 phase circuits complete in 12 drawings \$1.00. Box 999, Hugo, Minn.

(Continued from page 100)

Help Wanted

Silvering Mirrors, French Plate Taught. Easy to learn, immense profits. Plans free. Wear Mirror Works, Excelsior Springs, Mo.

Be a Mirror Expert. \$3 to \$10 a day; spare time home at first; no capital; we train, start you making and silvering mirrors French method. Free Prospectus. W. R. Derr, Pres., 579 Decatur Street, Brooklyn, N. Y.

Men—learn wireless at home quickly and easily. Attractive positions now open for men qualified as radio operators, electricians, mechanics, inspectors and draftsmen. Beginner operators now averaging \$200 per month; no previous experience or wireless education necessary to enter. Opportunity to travel and see the world or locate in land wireless work. Oldest and largest radio school in America; established in 1914. We train you through our home study course, or at our local schools to qualify for official license, and help you secure position on land or sea. Wireless outfit furnished for home practice. Free catalogue on request. National Radio Institute, Dept. 570, 14th and U Streets, N. W., Washington, D. C.

Men Wanted at \$35 to \$100 a week to make mechanical drawings. Work is easy, pleasant, and leads to higher positions in Industrial Field at excellent salaries. We furnish set of instruments, train you at home, in spare time, by practical method and help you qualify for position. Write today for particulars. Roy C. Claffin, Pres., Dept. 1438, 14th & T Sts., Washington, D. C.

Earn \$25 Weekly, spare time, writing for newspapers, magazines. Experience unnecessary; details free. Press Syndicate, 5665 St. Louis, Mo.

How to Obtain the Position You Want. Remarkable Suggestions! Powerful Letters! \$1.00. J. T. O'Neill, 1411 Thomas St., St. Paul, Minn.

Men Wanted for Detective Work. Experience unnecessary. Write J. Ganor, former U. S. Gov't Detective, 135 St. Louis.

Wanted immediately by U. S. Government. Hundreds men—women—girls, over 17. Permanent, steady positions. \$135 to \$195 monthly. No strikes or layoffs. Easy, pleasant office or outside work. Quick raise. Vacation with pay. Common education sufficient. Pull unnecessary. Write immediately for free list positions now open. Franklin Institute, Dept. K 25, Rochester, N. Y.

Men—be free now from frequent rising at night, depression, backache, sciatica, nervousness, tender feet. No drugs, diet or knife. Free book tells all. Write now. The Electro Thermal Co., 81 Y Kirk Bldg., Steubenville, Ohio.

Earn \$250 a month, expenses paid as RAILWAY Traffic Inspector. Outdoors, local or traveling. Start at \$110 monthly, position guaranteed after 3 months' spare time study. Write for Free Booklet G-57 Stand. Business Training Inst., Buffalo, N. Y.

Detectives earn big money. Excellent opportunity. Travel. Great demand everywhere. Experience unnecessary. Particulars free. Write American Detective System, 1968 Broadway, N. Y.

Be a Detective. Travel and earn big money. Learn this fascinating profession by home study. Particulars free. Write American School of Criminology, Dept. B, Detroit, Mich.

Firemen, Brakemen, Baggage-men, \$140-\$200, colored Porters by Railroads everywhere. Experience unnecessary. 897 Ry. Bureau. East St. Louis, Ill.

Be An Auto or Tractor Expert. Unlimited opportunity for advancement; your own business or working for others. 5,000 successful graduates. Good board reasonable near school. Catalog free. Cleveland Auto School, 1822 E. 24th St., Cleveland, Ohio.

Boys—Men. Become Automobile Experts. \$45 week. Learn while earning. Write Franklin Institute, Dept. K 806, Rochester, N. Y.

Business Opportunities

Beginners' Complete Mail Order System. S. Box 1005, Atlantic City.

Earn \$50 to \$75 per week, tuning and repairing pianos. We teach you to be an expert. Chicago School of Piano Tuning, River Forest, Ill.

Substantial manufacturing corporation wants capable men to establish branch and manage salesmen. \$300 to \$2000 necessary. Will allow expenses to Baltimore as explained. Address, Mr. Clemmer, 603 N. Eutaw St., Baltimore, Md.

Breed Canaries. Profitable pastime. Particulars free. Bird Farm, Lynnhaven, Virginia.

If you want to sell or exchange your farm, unimproved land, city property or patent, write me. John J. Black, 194th St., Chippewa Falls, Wis.

\$50.00 weekly, home evenings, my earnings, "Direct-Mail-Specialty" Business. Are you suited for this profitable business? Send 10c. for "Starter Test D"—then decide quickly! Proposition Bonafide! Ad-Builder Van, 645 North Gramercy, Los Angeles, Calif.

(Business Opportunities—Continued)

Make your own Gold and Silver polishing cloth or manufacture and sell them yourself. Formula sent on receipt of 50 cents. Agents make big money. J. E. Fuller Company, 503 South Fifth Ave., West, Newton, Iowa.

\$10 daily refinishing chandeliers, brass beds, automobiles by new method, without capital or experience. Free particulars and proofs. Write today. Gunmetal Co., Avenue D, Decatur, Ill.

Let us be your factory! Write today. Logan Machine Co., 222 S. Clinton St., Chicago, Ill.

Tattooing is a good paying proposition, start in business for yourself. Complete tattoo outfit for amateurs \$10.00. Send 10c for up-to-date price list. Harry V. Lawson, Box 31, Norfolk, Va.

"Money-Talks." The Business magazine published for progressive people. Send for sample copy. P. O. Box 236-B, Newark, New Jersey.

A live list of addresses of mail order buyers; three hundred for one dollar. Ray Rockwood, Hotel Hannah, Cleveland, Ohio.

For Sale. Improvement on Flat-irons; the iron that cannot fall off the handle, with patterns made ready for business. Address, The Wehr-Estridge Co., 539 E. Ludlow St., Hamilton, Ohio.

Enter a New Business. Earn \$3,000 to \$6,000 yearly in professional fees making and fitting a foot specialty, openings everywhere with all the trade you can attend to; easily learned by any one at home in a few weeks at small expense; no further capital required; no goods to buy; job hunting, soliciting or agency. Address Stephenson Laboratory, 18 Back Bay, Boston, Mass.

Automatic Auto Top. My latest invention. Get local rights to build and sell same in your locality. Real money maker. Official drawings and certificate mailed you upon receipt of \$10.00. Greatest improvement in the Automobile line today. Unequaled features. Address G. A. Stenson, Cokato, Minn., L. Box 132.

Make more money. Start manufacturing Kewpie dolls and novelties. 45c. worth plaster Paris makes dozen dolls worth \$12. List of buyers, special formula, instructions complete \$1. Seyviss, Sta. C., Box 43, Buffalo, N. Y.

Dollars Yearly in Your Back Yard. No ginseng, mushroom dope. New ideas. Investigate. Particulars free. Metz, 252 W. 41st St., New York.

Establish clean mail order business of your own, selling Mind Reading Books. Fine demand and profits. Write for details. Star Publishing Co., Desk 12, Oshkosh, Wis.

Books

Back Issues of this and other magazines supplied by Boston Magazine Exchange, 107 Mountfort St., Boston.

Books on All Subjects. New and second hand. Send for latest mechanical and scientific catalog. The Bargain Book Store, 520 South State Street, Chicago, Illinois.

300 Book Bargains on Occultism, Mind-reading, Spiritualism, Clairvoyance, Hypnotism, New Thought, Self-Culture, Drugless-Healing, Sex Secrets. Catalog free. C. E. Winegar, Pub., West Fort Ann, N. Y.

Mind-Reading? (any distance). Simply wonderful, yet wonderfully simple. 30c. Success guaranteed. "How to Hypnotize." Relieve diseases. Give astounding exhibitions. 126 pages, illustrated \$1.00. "Hypnotic Wonders" free. Science Institute SE-6435 North Clark, Chicago.

Books, Novelties, Classy Photos, Magical Goods. Catalogue 10c. J. M. Northen & Co., Walnut Ridge, Ark.

The Web of Destiny, how made and unmade. The Occult Effect of Our Emotions. Prayer—A Magic Invocation.—Practical Methods of Achieving Success. By Max Heindel. 180 Pages Cloth. Two dollars, Postfree. These are the collected fruits of the investigations of a Mystic, explaining the forces which shape our destiny from the invisible planes. This valuable information is given out for the first time in book form. Rosicrucian Fellowship, Box 132, Oceanside, California.

Free. Upon request I will send you illustrated literature describing the following entitled books; Astrology, Character-Reading, Clairvoyance, Concentration, Entertainment, Healing, Hypnotism, Mechanics, Mesmerism, Mysticism, Occultism, Personal Magnetism, Salesmanship, Success, Seership, Mediumship, Will, Yogi Philosophy, Gazing Crystals, etc. A. W. Martens, J. O. O., Burlington, Ia.

Sex Books for Professional and Advanced Adult readers. Modern Book Society, 230 West 52nd St., Desk 199, New York.

Trick Dealing Exposed. How they do it with any fair Deck of Cards—no marks, shiners, or device—method guarded for years. Will save you from unfair play. Will enable you to entertain audiences. Price only \$5.00. Sold for magic expose only. Order today. Selby Co., D-2A, Willow Hill, Ill.

The Amateur Electrician Pocket Size, 20c. (coin). Joel Tillberg, Proctor, Vermont.

(Books—Continued)

Try This for Luck. Something really worth while. How to be Happy and Successful in your love affairs. No Foolishness. Convincing Information. Send stamp for Valuable Free Literature. Woman's Educational Publishing Co., 98 2nd St., San Francisco.

Books, All kinds. Lists. Higene's, S-2441 Post Street, San Francisco.

Chemistry

Qualitative Analysis made easy. Concise text-book with charts and tables. Postpaid \$1.25. Make your "Lab" look scientific with our uniform gummed labels, containing names and formulae of several hundred chemicals. Postpaid \$1.00. Chebro Chemical Co., 178 Alsace St., Bridgeport, Conn.

Formulae, chemical supplies, analysis, experimental work. Douglas Chemists, 1530 S. Turner Ave., Chicago.

Scientific Laboratory Equipment—American Standards. Hoskin's Laboratory Heating Appliances—Coor's Scientific Porcelain—Nonsol Chemical Glassware—Baker's Analyzed Chemicals. Quality Apparatus, backed by reputation of manufacturer. Complete illustrated catalogue on request. D. Altman Company, 223-225 East 110th St., New York.

Startling, Mystifying Experiments! "Chem-set" contains chemicals and directions. Outfit one, 15c. Outfit two 20c. Both 30c. Mystic 714 Vinton, Waterloo, Iowa.

Wonderful Experimental Book. Make your own Chemical and Scientific Apparatus, tests, solutions. Over 100 original Experiments. 76 pages, fully illustrated, 35 cents postpaid. No stamps accepted. Descriptive circular for stamp. Palmers Electrical Equipment Co., Palmers, Minn.

Chemicals in suitable containers 25c each. Reagents in glass stoppered bottles 35c. each. Prices on larger quantities on request. D. T. S., 211 West 102 St., New York City.

Chemistry. Learn Qualitative Analysis by the modern simplified chart method. U. S. \$1.00. Foreign countries \$2.00. Technical Charts, Dept. C-3, 1038 W. Chicago Ave., Chicago, Ill.

Experimenters. We carry a complete stock of chemicals and chemical apparatus for your laboratory. Catalogue 5 cents. National Scientific Supply Co., 241 Pa. Ave., Washington, D. C.

Chemical Apparatus. Rare chemicals. Radioactive minerals. Lowest prices. Bulletins for stamp. Enola Scientific Company, 1405 Florida Ave., N. W., Washington, D. C.

Correspondence Courses

Dollars Saved. All kinds of used correspondence courses sold. (Courses bought.) Lee Mountain, Pisgah, Ala.

Exchange

Typewriter for sale or trade for Kodak or Binoculars. W. P. Smith, Crescent, Iowa.

Bargain. Cyclomotor Parts, nearly new. Harry Nelson, Haverstraw, N. Y.

Exchange. Photographic, wireless and other electrical goods; also phonograph records and supplies. Write for list. Walker Kelly, Fayetteville, Ark.

For Sale. High Power Microscope. Almost new. Bargain. Write for particulars. P. S. Howard, Box 683, Okmulgee, Okla.

Will sell set of bronze forms for making toy metal soldiers. Cheap. Frank P. Moreton, 1806 Mount Salem St., Wilmington, Delaware.

For Sale. Complete I. C. S. Electrical Engineering Course, never been used. Reference volumes. Gorge Niman, Polo, Illinois.

Sell. Weston Ammeter 0-50 A. A. C. Cost \$20, sell \$8. C. McLaughlin, Cadiz, Ohio.

Master Key Lessons, one set \$20; New \$40. Jace, Box 1333, Paterson, N. J.

Wireless

Stop! Look! and Think! 5 to 30% discount on new well-known regenerative sets, vacuum tubes, power tubes, radiophones and accessories. \$45 Magnavox Loud speakers at \$39. The Kehler Radio Laboratories, Dept. 2, Abilene, Kansas.

For Men

New Method. For re-sharpening razor blades. Velvet edges. "Makes the Shaver Smile." One edge 2c., double 3c. each. Satisfaction guaranteed. Two blades re-sharpened free as samples. Send now. F. Lohmar, Box 86, Duluth, Minn.

Send Us Your Dull Safety Razor Blades. We will resharpen them so that they will shave better than new ones for 3 cents each, any kind. Old fashioned razors reground and repaired. Satisfaction guaranteed or money refunded. Send two cent stamps, twenty-five cent books preferred. Keenedge Co., 1 S. Robey St., Chicago, Ill.

Men past middle life send for Free Book on gland faults. If depressed, if backache, sciatica or tender feet and disturbed sleep are taking your health, you need this book. Send today. The Electro Thermal Co., 81 X, Kirk Bldg., Steubenville, Ohio.

(Continued on page 102)

(Continued from page 101)

(For Men—Continued)

Detectives earn big money. Travel. Great demand. Fascinating work. Experience unnecessary. We train you. Particulars free. Write, American Detective System, 1968 Broadway, N. Y.

Some Class to You Bill. That's what they'll say when you wear one of our beautiful gold filled pocket knives. Price \$1.00. Gordon, Box 1323, San Francisco, Cal.

A 75c Pocketbook for 25c. This handsome billfold guaranteed solid leather. A money maker for agents. Boucher, Kimball St., Bradford, Mass.

For Inventors

"Sell or Finance Inventions." Send for free sample copy of Money-Talks Magazine. P. O. Box 236-B, Newark, N. J.

Neat, readable drawings, made from your rough sketch or model. One dollar. Thos. H. Duffy, 109 6th Ave., Juniata, Pa.

Mr. Inventor. If I don't build your Patterns, Models and Experimental Work, Metal or Wood Novelties, we both lose money. No noise, good work, sudden service, your price. That's me. Walter M. Donahue, 2107 Division Street, Fort Madison, Iowa.

Experts in experimental and model work. All mechanical lines. Inventions perfected. Designs, Labor saving machinery, devices, dies a specialty. 20 years' practical experience. Services strictly confidential. Andrew's Experimental and Model Works, Madison, Wis.

Get your own patent. \$35 complete. Application blanks, forms and full instructions \$1. Theodore A. Cutting, Campbell, Cal.

Inventors obtain my proposition before filing or disposing of your patent. H. Kaye Martin, 21 Park Row, New York.

"Inventors' Guide" free on request; gives valuable advice and information for all inventors. Write Frank Ledermann, Registered Patent Attorney, 17 Park Row, New York.

Inventors, protect yourselves. Record idea before exposing it to anyone, even myself or other attorneys. Klein Cons. Eng. Reg. Patent Attorney, 21 Park Row, New York.

Inventors your fortune is made. Address William Hoppie, Montello, Nevada.

Inventors. Registered Attorney, employed by old established firm, will assist inventors in patent matters at moderate charges. Ralph H. Hoffman, Park Row Building, New York.

Inventors write me about patents. My fees payable monthly. Booklet free. Frank Fuller, Washington, D. C.

900 Mechanical Movements, also illustrations explaining 50 Perpetual Motions. My book, "Inventor's Universal Educator," fifth edition, tells how to procure and sell patents. Government and other costs. Covers the matter from A to Z. 160 pages elegantly bound. Contains noted decisions of U. S. Supreme and State Courts on patent cases. Mechanical Movements greatly assist inventors, suggest new ideas that may prove of great aid in perfecting inventions. Tells how to select an attorney. Has valuable information regarding Patent Sharks, Selling Agents and Brokers. Price \$2. Postage free everywhere. Fred G. Dietrich, 603 Ouray Bldg., Washington, D. C.

For the Hair

Hair grown on bald heads. Falling hair stopped. Many proved cases. Indians' secret. Proof box, with testimonials, guarantee, mailed 10 cents, silver or stamps. Kotalko Offices, BD-300, Station X, New York.

For the Photographer

Do You Take Pictures? Write for free sample of our big magazine, showing how to make better pictures and earn money. American Photography, 465 Camera House Boston, Mass.

Mail Order Business

I made \$25,000 with small Mail Order Business home. Sample article 25c. Free Booklet, Stamp. Al Exp. Scott, Cohoes, N. Y.

Musical Instruments

Violins, deep, mellow, soulful, on credit. Easy terms for wonderful instrument. Get details today. Gustav A. Henning, 2424 Gaylord St., Denver, Colo.

Novelties

Get "Transfero." Transfers printed pictures to paper and cloth. 25c. coin. H. Harris, 104 East 118th St., N. Y. C.

Genuine Indian Baskets. Wholesale catalogue. Marion Gihlms, Highland Springs, Calif.

Old Coins Wanted

We Buy and Sell Old Coins. \$2 to \$500 each paid. Keep All Old Money; you may have valuable coins. Send 10c. for New Illustrated Coin Value Book, 4 x 6. Guaranteed prices. Get posted. Clarke Coin Co., Box 110, Le Roy, N. Y.

Patent Attorneys

Patents. Send for free booklet. Highest references. Best results. Promptness assured. Send model or drawing for examination and opinion. Watson E. Coleman, patent attorney, 624 F St., Washington, D. C.

Inventors. My clients know every step taken in prosecuting their applications. Booklet sent free on request. Cubberly and Kessenich, 22, National Union Bldg., Washington, D. C.

Patents. Send for free book. Contains valuable information for inventors. Send sketch of your invention for Free Opinion of its patentable nature. Prompt service. (Twenty years' experience.) Talbert & Talbert, 4287 Talbert Bldg., Washington, D. C.

Patents. Prompt, personal, efficient service by an attorney-at-law, skilled in all branches of Patent Practice. Over 12 years' actual experience; full information upon request. B. P. Fishburne, 330 McGill Bldg., Washington, D. C.

Inventors. Before disclosing your invention record it as priority evidence. Personal and efficient patent service by an Engineer and Reg. Patent Lawyer. Maxwell E. Sparrow, 21 Park Row, New York City.

Patents. Herbert Jenner, patent attorney and Mechanical Expert, 622 F St., Washington, D. C. I report if patent can be had and its exact cost. Send for circular.

Patents Secured. Prompt service. Avoid dangerous delays. Send for our "Record of Invention" form and Free Book telling How to Obtain a Patent. Send sketch or model for examination. Preliminary advice without charge. Highest references. Write today. J. L. Jackson & Co., 114 Ouray Bldg., Washington, D. C.

Monroe Miller, Ouray Building, Washington, D. C., patent attorney, mechanical and electrical expert. Best quality of work and results. Moderate charges.

Inventors. Send for form "Evidence of Conception" to be signed and witnessed. Form, Fee Schedule, Information Free. Lancaster and Allwine 242, Ouray Bldg., Washington, D. C.

Millions Spent Annually for Ideas! Hundreds now wanted! Patent yours and profit! Write today for free books—tell how to protect yourself, how to invent, ideas wanted, how we help you sell, etc. 212 Patent Dept., American Industries, Inc., Washington, D. C.

Patents Procured. Trade Marks Registered—A comprehensive, experienced, prompt service for the protection and development of your ideas. Preliminary advice gladly furnished without charge. Booklet of information and form for disclosing idea free on request. Richard B. Owen, 130 Owen Building, Washington, D. C., or 2278-T Woolworth Bldg., New York.

Patents, trade-mark, copyright, inventors, business men, artists, write. Metzger, Washington.

Phonographs

Build a genuine Choraleon Phonograph and save over half. Fine profits building and selling. We furnish motors, tone arms and necessary parts. Send for our catalog and free blueprint offer. Choraleon Phonograph Co., 521 14th St., Elkhart, Ind.

Build Your Phonograph. "Perfection" high quality spring and electric motors, tone arms, reproducers. Wonderful results. Big saving—New catalog and building instructions mailed for 10 cents. Indiana Phonograph Supply Co., Indianapolis, Ind.

Build your own phonographs and manufacture them for profit. Drawing, Instructions, Parts Price List, Blue Print, etc., complete, sent free upon request. Write today. Associated Phonograph Co., Dept. E 1, Cincinnati.

Photo Developing

Mail us 20c. any size film for development—and six velvet prints. Or send six negatives any size and 20c. for six prints. Or send 40c. for one 8 x 10 mounted enlargement. Prompt, perfect service. Roanoke Photo Finishing Co., 255 Bell Ave., Roanoke, Virginia.

Postcards and Pictures

Girl Pictures You Like. Beautiful forms; fascinating poses. Size 3 x 5 inches. Samples and illustrated literature, 25c. Select Club, E., Box 166, Topeka, Kans.

Photographs, Art books, 25c. Special art, \$1.00. Miniature card, 10c. European Supply, Box 12, Dept. S, Uptown Station, Pittsburgh, Pa.

Special. Twenty clever, classy, assorted postcards, 10c. coin. Swanson, 1205E Kansas Avenue, Kansas City, Kansas.

Beautiful photographs of Oriental dancing girls. Nine assorted autographed postcards of Flozari, one dollar. Two assorted of Niletta, Flozari, or Egypta for quarter. Sample of either, fifteen cents each. Princess Flozari Dancers, Hotel Hannah, Cleveland, Ohio.

Health

Pyorrhea (Rigg's Disease, Bleeding or Swollen Gums). Hundreds have been helped by "Pyorrdent," the successful home Pyorrhea treatment. Purifying, healing, preventative. Full month's treatment, consisting of a very beneficial massage paste and an antiseptic tooth-cleaning paste to be used in place of your ordinary dentifrice, together with full directions for treatment, \$1 postpaid. Or write for free Booklet "E." Pyorrdent Mfg. Co., 439 Seventh St., Brooklyn, N. Y.

Cure yourself of piles using simple herb. Particulars free. D. M. Remson, Talladega, Ala.

Tobacco Habit. Quit easily. Chewing, smoking, snuff cured or no charge. Full remedy on trial. If cured, \$1.00. Stops craving; harmless. Perkins Co., M-11, Hastings, Neb.

Southern Wild Root cures tobacco habit. Large bundle 50c. silver. A. C. Remson, Talladega, Ala.

Tobacco, Liquor and Morphine habits have been successfully treated for the past 35 years with Hill's Chloride of Gold Tablets. Why not overcome these Health-destroying Habits? Full information, Literature and Testimonials sent upon request. The Ohio Chemical Works, Dept. 7, Charleston, S. C.

Reduce weight happily. Improve figure, alertness, health. Lengthen your life. Get Korein tabules, any druggist. Book mailed free. Korein Co., NB-300, Station X, New York.

Tobacco or Snuff Habit Cured or no pay; \$1.00 if cured. Remedy sent on trial. Superba Co., S.A., Baltimore, Md.

Free. Stop using tobacco. We will give free information how to conquer habit easily and permanently. Results guaranteed. Anti-Tobacco League, Dept. C, Omaha, Nebr.

Electric Vibrator! Unused \$37 White Cross outfit cheap. Description for stamp. Tripp, "Avalon" Tacoma, Wash.

Incorporation

Incorporation in Arizona Completed in One Day. Any capitalization, least cost, greatest advantages. Transact business anywhere. Laws, By-Laws and forms free. Stoddard Incorporating Co., 8-W, Phoenix, Ariz.

Instruction

Detectives earn big money. Excellent opportunity. Learn fascinating profession by correspondence. Great demand everywhere. Particulars free. Write, American Detective System, 1968 Broadway, N. Y.

Shorthand, learn complete system, few evenings (home) then acquire speed, pleasant practice. Brochure free. Save money, time, increase your efficiency, earnings. King Institute, EO-300, Station F, New York.

Mathematics. Drafting—Surveying correspondence courses, reasonable. Engineer-Instructor, 21 years' experience. Box 84, Sta. A, Chattanooga, Tenn.

Personal

Pleasant Root inexpensively overcomes any tobacco habit. Fine for stomach. Send address. Marshal Stokes, Mohawk, Florida.

Scenery for Hire

Collapsible Scenery and Plush Drops. Amelia Grain, Philadelphia.

Stammering

St-Stu-t-t-tering and Stammering cured at home. Instructive booklet free. Walter McDonnell, 105 Potomac Bank Bldg., Washington, D. C.

Stammerers. My simple and natural method will correct your impediments. Instruction individual. Samuel I. Robbins, 246 Huntington Avenue, Boston.

Stamps and Coins

55 All different stamps, including China, Japan, French Colonies, etc., given to applicants for our high grade approval selections. Send references and 2c. stamp to the Edgewood Stamp Co., Dept. I, Milford, Conn.

California Gold, quarter and Colombia nickel coin 30c. Italy 20 coin and catalogue 10c. Homer Schultz, King City, Mo.

Stamps, 100 all different, \$10c. George Gauld, 26 Bay St., Hamilton, Ontario.

100 Different Stamps. Nicaragua, Salvador, Victoria, Brazil, Chile, large Pictorial French Colonies, etc. Album with perforation gauge, only 10c Silver. Stamp collections and accumulations bought. Clarence Gibbs, 8932 Juniper, Los Angeles, Cal.

Stamps—20 Unused, all Different, Free. Postage, 3c. Mention paper. Quaker Stamp Co., Toledo, Ohio.

Stamps Free, 75 Different. L. G. Baird, 1108 Jackson St., Eugene, Oregon.

California Gold, quarter size, 27c; half-dollar size, 53c. Columbian nickel and catalogue 10c. Norman Shultz, Box 146, Colorado Springs, Colo.

(Continued on page 103)

(Continued from page 102)

Motion Pictures—Motion Picture Plays

Wanted. Men and women ambitious to make money writing Stories and Photoplays. Send for wonderful Free Book that tells how. Authors' Press, Dept. 131, Auburn, N. Y.

\$35 Profit Nightly. Small capital starts you. No experience needed. Our machines are used and endorsed by Government institutions. Catalog free. Atlas Moving Picture Co., 470 Morton Bldg., Chicago, Ill.

Make \$25.00 to \$50.00 Nightly. We furnish professional machine, films, supplies, etc., suitable for traveling or stationary use. No experience needed. We teach you this business. Little money required. Easy payments. Large catalogue free. Dept. 610, Monarch Theatre Supply Co., 537 South Dearborn St., Chicago.

Earn \$1,200 a year in spare time writing photoplays. Experience unnecessary. Send for free book, valuable information. Special prize offer. Photo Playwright College, Box 278 E-15, Chicago.

Photoplays Wanted. Big prices paid. You can write them. We show you how. Free particulars. Rex Publishers, Box 175, E-25, Chicago.

Miscellaneous

Electrical Tattoo Machines. Tattooing Designs, Colors. Send 10c. for Price List of Tattooing Supplies. Harry Lawson, Box 31, Norfolk, Va.

5 Master Keys and novel key chain \$1.00. Open and test thousands of different locks. They have satisfied thousands of purchasers, and are used by locksmiths, detectives, travelers, firemen, mechanics. Master Key Co., 57 Manhattan Building, Milwaukee, Wis.

Stills. For Water, Oils, Liquids, all drinking purposes; gallon hourly; \$15 up prepaid, circular free. European Supply Co., Box 1682, Dept. S, Pittsburgh, Pa.

Models

Designing, Developing, Working Models; 22 years' experience. E. Porsberg, Box 47, Northfield, Ohio.

Model Makers, Boat Builders. Send 20c. for catalogue, blue prints showing engines, boilers, fittings, parts. Lathes quoted upon request. Model Makers Supply, 505 Fifth Ave., New York.

Printing

100 Letterheads and Envelopes, \$2.00. Jacobus Service, 41 Bruen, Irvington, N. J.

Labels 60c. per 1,000 up. Wolf, Sta. E, Desk J, Philadelphia.

100 cards, envelopes, noteheads, letterheads, or labels, 50c. Extra hundreds, 35c. Scott, 211 Eleventh, Newark, Ohio.

Everything printed. Long run specialties. Samples. Quality Printery, Marietta, Ohio.

250 Bond Letter Heads, Bill Heads, Envelopes and Cards, Complete \$5.00. 250 Letter Heads and Envelopes \$2.75. Balkow Printing Company, Meridan, Conn.

Letterheads, Envelopes, Cards, We Print them. Give us a chance to bid. Kwick Service Shop, Box 265, Grand Forks, N. D.

Short Stories, Manuscripts Wanted

Short Stories, poems, plays, etc., are wanted for publication. Literary Bureau, 165 Hannibal, Missouri.

Earn \$25 Weekly, spare time, writing for newspapers, magazines. Experience unnecessary; details free. Press Syndicate, 566 St. Louis, Mo.

Song Poems

Write the Words for a Song. We will write the music and guarantee publication on a royalty basis. Submit poems on any subject. Seton Music Company, 920 S. Michigan Ave., Room 111, Chicago, Ill.

You Write the Words for a Song. We'll compose the music free and publish same. Send Song Poem today. S. Lenox Co., 271 West 125th St., New York City.

You Write Words for a Song. We write the music, publish, and secure a copyright. Submit poems on any subject. The Metropolitan Studios, 914 S. Michigan Ave., Dept. 209, Chicago, Ill.

Write a Song Poem. I compose music and guarantee publication. Send poem today. E. Hanson, 3810 Broadway, Room 108, Chicago.

Write a Song Poem. Love, mother, home, comic or any subject. I compose music and guarantee publication. Send words today. Edward Trent, 679 Reaper Block, Chicago.

Stamping Names

Make \$19 a Hundred stamping names on keychecks. Send 25c for sample and particulars. Ex Kaytag Co., Cohoes, N. Y.

Telegraphy

Telegraphy (both Morse and Wireless) and Railway Accounting taught quickly. Tremendous demand. Big salaries. Great opportunities. Oldest and largest school; established 46 years. All expenses low—can earn large part. Catalogue free. Dodge's Institute, O St., Valparaiso, Indiana.

Tricks, Puzzles and Games

Send Stamp for large (beautifully illustrated) catalogue which contains all the latest tricks, jokes, puzzles and illusions. Oaks Magical Co. Dept. 549, Oshkosh, Wis.

Rubber Stamps

Rubber Stamps made to order. McCaddon Co., Zanesville, Ohio.

Formulas

1,000,000 Formulas. Processes, Trade Secrets for every business. 1016 pages, \$2.25. Ideal Book Shop, 5501-EE North Robey, Chicago.

Book of great secrets. Valuable recipes and formulas 25c. Postpaid. Englewood Book Shop, 7021 South Winchester, Chicago.

3,384 Money-Making Plans. Formulas, Trade-Secrets. "Encyclopedia Business Opportunities." 3 volumes \$1.50. Ideal Book Shop, 5501-EV North Robey, Chicago.

Formulas—all kinds—catalogue free. Best-ovall Laboratories, 4047 N. Whipple, Chicago.

Formulas—All Kinds. Guaranteed. Catalog 2c. Clover Laboratories, 5501-EC North Robey, Chicago.

American Made Toys

Manufacturers wanted for larger productions and homeworkers on smaller scale for Metal Toys and Novelties. Toy Soldiers, Cannons, Cowboys, Indians, Buffalo Bills, Wild Animals, Whistles, Bird Whistles, Race Horses, Prize Fighters, Religious Statuettes, Puzzles and hundred of other Toys and Novelties. Hundred and more made complete per hour. No experience or tools needed. Bronze Casting forms with complete outfit from \$5.00 up. We are buyers of these goods all year, paying fixed prices. Contract orders placed with manufacturers. Exceptional high prices paid for painted goods. An enormous business offers industrious men an excellent opportunity to enter this field. An open market for these goods all over United States, Canada and South America. Write us only, if you mean business. Illustrated catalogue and Booklet mailed free. Toy Soldier Manufacturing Company, Offices and Showrooms, 1696 Boston Road, New York.

Wanted to Buy

You can raise cash by mailing us any old, broken jewelry, diamonds, platinum, broken watches, false teeth, bracelets, old gold, silver, silver plate, magneto points, platinum wire, contact points, or crucibles, mercury and all valuables. We pay the highest prices in spot cash by return mail, and will return your goods in ten days if you're not satisfied. The Ohio Smelting & Refining Company, 206 Lennox Bldg., Cleveland, Ohio.

We positively pay full value for old or new jewelry, watches, diamonds, crowns and bridges, dental gold, silver, platinum, gold or silver ore, magneto points (old or new) war bonds and stamps, old false teeth. Send by mail or express. We hold packages 4 to 12 days and return same at our expense if our offer is not satisfactory. United States Smelting Works. (The Old Reliable) 120 So. State St., Dept. 73, Chicago, Ill.



Learn Drafting

Employers everywhere are looking for skilled draftsmen. They are offering good salaries to start with splendid chances for advancement.

Drafting offers exceptional opportunities to a young man because drafting itself not only commands good pay, but it is the first step toward success in Mechanical or Structural Engineering or Architecture. And drafting is just the kind of work a boy likes to do. There is an easy delightful way in which you can learn right at home in spare time. For 29 years the International Correspondence Schools have been giving boys just the training they need for success in Drafting and more than 200 other subjects. Thousands of boys have stepped into good positions through I. C. S. help, but never were opportunities so great as now.

Let the I. C. S. help you. Choose the work you like best in the coupon, then mark and mail it. This doesn't obligate you in the least and will bring you information that may start you on a successful career. This is your chance. Don't let it slip by. Mark and mail this coupon now.

INTERNATIONAL CORRESPONDENCE SCHOOLS
BOX 6192-B SCRANTON, PA.

Explain, without obligating me, how I can qualify for the position, or in the subject, before which I mark X.

- | | |
|--|--|
| <input type="checkbox"/> ELECTRICAL ENGINEER | <input type="checkbox"/> SALESMANSHIP |
| <input type="checkbox"/> Electric Lighting and Its | <input type="checkbox"/> ADVERTISING |
| <input type="checkbox"/> Electric Wiring | <input type="checkbox"/> Window Trimmer |
| <input type="checkbox"/> Telegraph Engineer | <input type="checkbox"/> Show Card and Sign Ptg. |
| <input type="checkbox"/> Telephone Work | <input type="checkbox"/> Railroad Positions |
| <input type="checkbox"/> MECHANICAL ENGINEER | <input type="checkbox"/> ILLUSTRATING |
| <input type="checkbox"/> Mechanical Draftsman | <input type="checkbox"/> Cartooning |
| <input type="checkbox"/> Machine Shop Practices | <input type="checkbox"/> BUSINESS MANAGEMENT |
| <input type="checkbox"/> Toolmaker | <input type="checkbox"/> Private Secretary |
| <input type="checkbox"/> Gas Engine Operating | <input type="checkbox"/> Business Correspondent |
| <input type="checkbox"/> CIVIL ENGINEER | <input type="checkbox"/> BOOKKEEPER |
| <input type="checkbox"/> Surveying and Mapping | <input type="checkbox"/> Stenographer and Typist |
| <input type="checkbox"/> MINE FOREMAN or ENGR | <input type="checkbox"/> Cert. Pub. Accountant |
| <input type="checkbox"/> STATIONARY ENGINEER | <input type="checkbox"/> TRAFFIC MANAGER |
| <input type="checkbox"/> Marine Engineer | <input type="checkbox"/> Railway Accountant |
| <input type="checkbox"/> Ship Draftsman | <input type="checkbox"/> Commercial Law |
| <input type="checkbox"/> ARCHITECT | <input type="checkbox"/> GOOD ENGLISH |
| <input type="checkbox"/> Contractor and Builder | <input type="checkbox"/> General School Subjects |
| <input type="checkbox"/> Architectural Draftsman | <input type="checkbox"/> CIVIL SERVICE |
| <input type="checkbox"/> Concrete Builder | <input type="checkbox"/> Railway Mail Clerk |
| <input type="checkbox"/> Structural Engineer | <input type="checkbox"/> AUTOMOBILES |
| <input type="checkbox"/> PLUMBING and HEATING | <input type="checkbox"/> Mathematics |
| <input type="checkbox"/> Sheet Metal Worker | <input type="checkbox"/> Navigation |
| <input type="checkbox"/> Textile Overzeer or Supt. | <input type="checkbox"/> AGRICULTURE <input type="checkbox"/> Spanish |
| <input type="checkbox"/> CHEMIST | <input type="checkbox"/> Poetry Making <input type="checkbox"/> Baking |
| <input type="checkbox"/> Pharmacy | |

Name _____ Business _____ 1-1-21
 Present Occupation _____ Address _____
 Street _____
 and No. _____
 City _____ State _____

Canadians may send this coupon to International Correspondence Schools Canadian, Ltd., Montreal, Canada

WANTED
RAILWAY
MAIL
CLERKS

\$1600 to \$2300 a
Year In It
for You

Men—Boys—Over 17—should write at once

Hundreds of Railway Mail Clerks Appointed Yearly. Rapid advancement to higher Government Positions. "No lay-offs." The Position is Yours for Life.

Country residents and city residents stand the same chance for immediate appointment. Common-sense education sufficient. Political Influence NOT REQUIRED. Write immediately for schedule showing the places and dates of ALL SPRING Government examinations. Don't delay. Every day you lose means the loss of just so much coaching before the rapidly approaching examinations.

FRANKLIN INSTITUTE, Dept. K184, Rochester, N. Y.



FRANKLIN INSTITUTE (The Pathway to Plenty)
Dept. K184, Rochester, N. Y.

This coupon, filled out as directed, entitles the sender to free specimen questions; a free copy of our book "Government Positions and How to Obtain Them"; a list of Government positions now open, and in consideration for Free Coaching for the examination here checked.

COUPON

R'way Mail Clk \$1600-2300	Bookkeeper	\$1240-1440
Postoffice Clerk \$1400-1800	Postoffice Carrier	\$1400-1800
Rural Mail Car. \$ 720-2600	Customs Positions	\$1100-2000
Stenographer	\$1100-2000	File Clerk
Clerk in the Departments at Washington	\$1340-1840	
	\$1200-1800	

Name _____ Address _____
 Use this before you lose it. Write plainly.

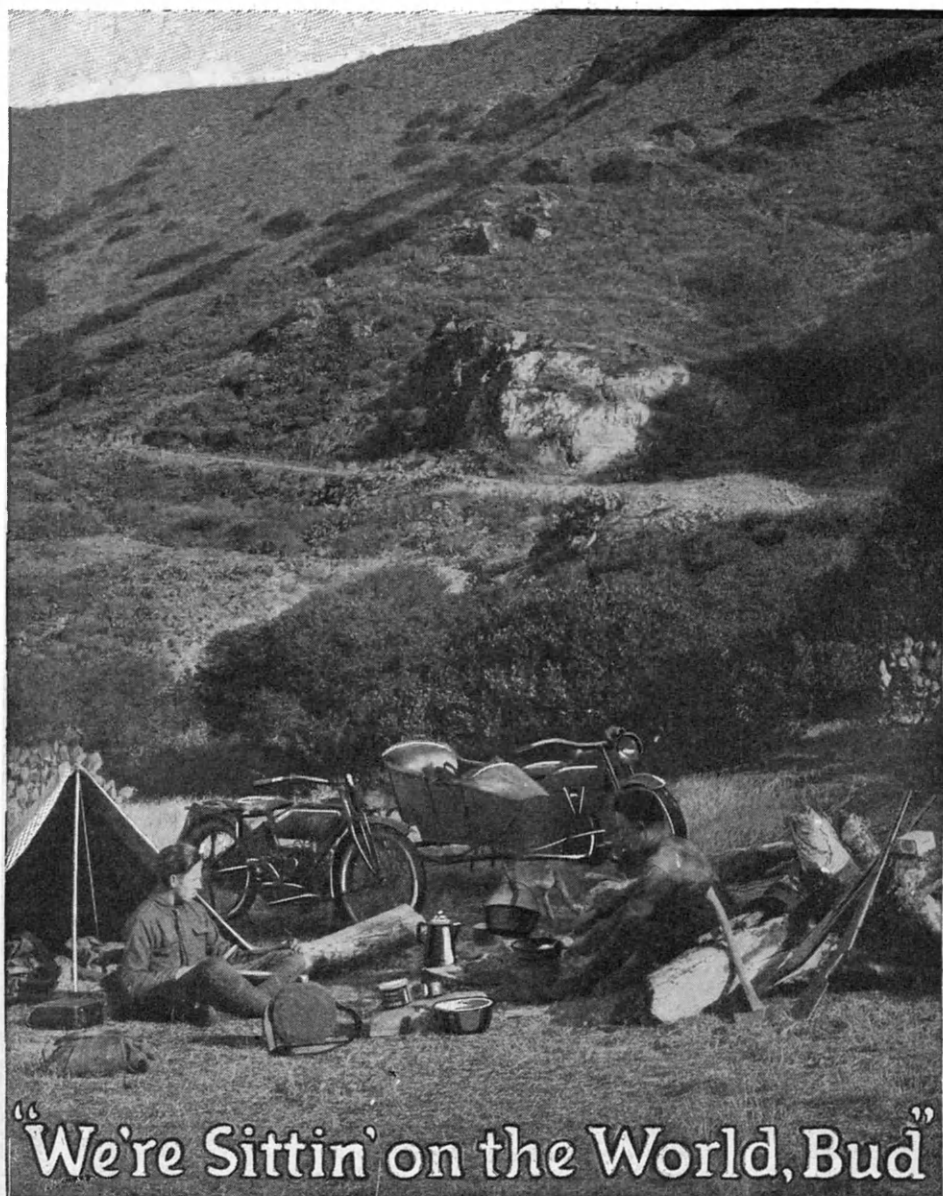

"We're Sittin' on the World, Bud"

"I'VE tried everything on wheels, Bud—from limousines on Fifth Avenue to caissons in France—but you've got to hand it to a motorcycle when you want real sport."

"You tell 'em, Jim. A Harley-Davidson is good enough for me any day. All she needs is a place to go and she'll get you there, road or no road. And you don't have to own a mint to ride a motorcycle either."

"You're right, Bud. Fifty miles for a dollar sure listens good to me. And my side car carries enough grub and luggage for both of us. Gimme a match, Bud."

Motorcycling is cheaper than car fare—cheaper than shoe leather—and it's "the Greatest Sport in the World." Ask the Harley-Davidson dealer for a demonstration. Or write to us for literature.

HARLEY-DAVIDSON MOTOR CO.
MILWAUKEE, WISCONSIN

Harley-Davidson
"World's Champion"



Every Electrical Man Wants These Books and we ship them for your inspection **FREE**

Flexible
Covers
—
Handy
Pocket
Size
Volumes

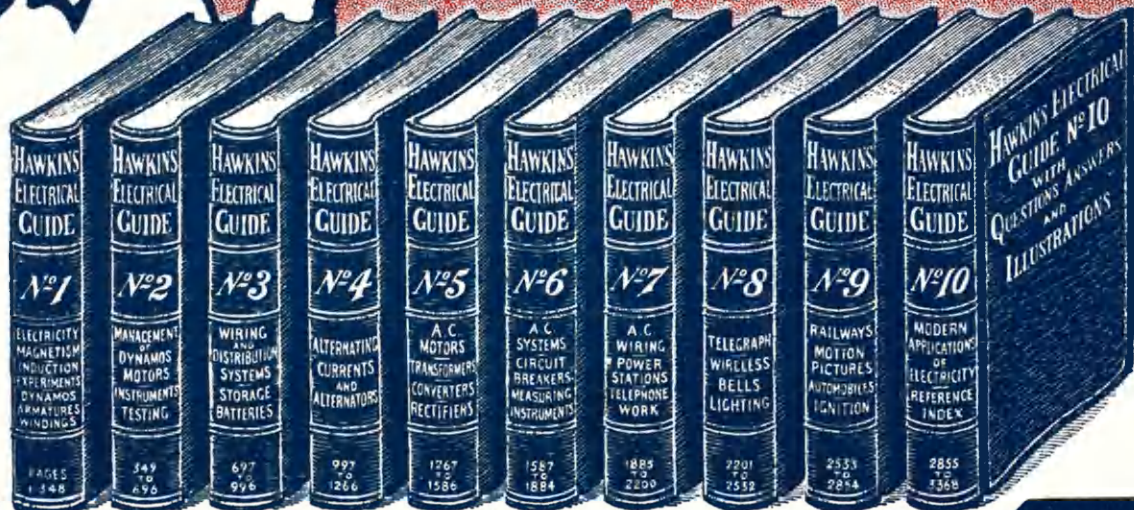

10
Volumes
3500
Pages
4700
Pictures
\$1 Per
Volume
\$1 Per
Month

Just what you need to know to succeed in **ELECTRICITY**

EVERY electrician, every engineer, every mechanic should know about these wonderfully helpful instructive books, which give in plain words a complete working knowledge of electrical engineering in all its phases.

You run into some new electrical problem almost every day. The information you need to help you in your every day work is in

HAWKINS ELECTRICAL GUIDES

These books place electricity at your finger ends. They cover every imaginable subject, principle, theory, problem, trouble, and way of doing things electrically. Every subject is indexed so that you can turn right to it. They are a study course and a reference guide in one, written in plain every day language—no wasted words—only what you need to know—chock full of up-to-the minute electrical knowledge. The guides are a complete course in electrical engineering. They will help you in every detail of the day's electrical work. You can't ask an electrical question that Hawkins Guides can't answer.

Pocket - Size Flexible Covers

The books are small enough to slip into your coat pocket—handsomely bound in flexible black covers.

You can carry each volume with you until you have mastered its contents. 3,500 pages of actual information and 4,700 illustrations. Once you see these books and put them into actual use you will never again want to be without them. Try it at our expense.

SEND NO MONEY

It will cost you nothing to receive these books—to look them over—ask them all the questions you can think of—use them in your work—study them—pick up some information that will increase your earning ability. We will ship you the entire set of 10 volumes entirely FREE.

This is a sign of our confidence in the guides. Pure gold does not object to being tested. Keep them for seven days and if you do not decide that you can't get along without them, return them to us and owe us nothing.

When you decide to keep them you only have to pay \$1.00 down and remit the balance of \$9 on the easy payment of \$1.00 a month till paid for.

Use this coupon to get the books. It will pay you many times over.

THEO. AUDEL & CO.
72 Fifth Ave. New York, N. Y.

SEND NO MONEY - USE THE COUPON

READ THIS PARTIAL LIST OF CONTENTS

- No. 1** Contains 348 pages, 388 illustrations. Electrical signs and symbols—static and current electricity—primary cells—conductors and insulators—resistance and conductivity—magnetism—induction coils—Lytium principles—classes of dynamos—armatures—windings—commutation—brushes, etc.
- No. 2** Contains 348 pages, 394 illustrations. Motor principles—armature reaction—motor starting—calculations—brake horsepower—selection and installation of dynamo and motors—galvanometers—standard cells—current measurement—resistance measurement—voltmeters—wattmeters—watt hour meters—operation of dynamos—operation of motors, etc.
- No. 3** Contains 300 pages, 423 illustrations. Distribution systems—wires and wire calculations—inside, outside and underground wiring—sign flashers—lightning protection—rectifiers—storage battery systems, etc.
- No. 4** Contains 270 pages, 379 illustrations. Alternating current principles—alternating current diagrams—the power factor—alternator principles—alternator construction—windings, etc.
- No. 5** Contains 320 pages, 614 illustrations. A. C. Motors—synchronous and induction motor principles—A. C. commutator motors—induction motors, transformers; losses, construction, connections, tests—converters, rectifiers, etc.
- No. 6** Contains 298 pages, 472 illustrations. Alternating current systems—switching devices—circuit breakers—relays—lightning protector apparatus—regulating devices—synchronous condensers—indicating devices—meters—power factor indicators—wave form measurement—switchboards, etc.
- No. 7** Contains 316 pages, 379 illustrations. Alternating current, wiring power stations—turbines; management, selection, location, erection, testing, running, care and repair—telephones, etc.
- No. 8** Contains 332 pages, 436 illustrations. Telegraph—simultaneous telegraphy and telephony—wireless—electric bells—electric lighting—photometry, etc.
- No. 9** Contains 322 pages, 627 illustrations. Electric railways—electric locomotives—car lighting—trolley car operation—miscellaneous applications—motion pictures—gas engine ignition—automobile self-starters and lighting systems, electric vehicles, etc.
- No. 10** Contains 513 pages, 599 illustrations. Elevators—cranes—pumps—air compressors—electric heating—electric welding—soldering and brazing—industrial electrolysis—electro plating—electro-therapeutic—X-rays, etc.

Also a complete 126-page ready reference index of the complete library. This index has been planned to render easily accessible all the information contained in the 10 electrical guides. There are over 13,500 cross references. You find what you want to know instantly.

THEO. AUDEL & CO.
72 Fifth Ave.
New York, N. Y.

Please submit me for examination, Hawkins Electrical Guides (price \$1 each). Ship at once, prepaid, the 10 numbers. If satisfactory I agree to send you \$1 within seven days and to further mail you \$1 each month until paid.

Signature.....
Occupation.....
Employed by.....
Residence.....
Reference..... S. & I May

What Electrical Men Say

Helped Him Make Good

"It is only right for me to recommend highly the Hawkins Guides, for they have been of the greatest assistance to me in placing me in my present position as Superintendent of Construction Department of one of Ohio's largest Electrical Companies. I would like to see every man have a set of Hawkins Guides."

Geo. Knecht, Columbus, Ohio.

In the Naval Electrical Dept.

"The Hawkins Guides are great help to me in the Naval Electrical Department, which they cover very thoroughly."

C. J. Cornell
U. S. Receiving Ship, Brooklyn, N. Y.

Superintendent

"I am now superintendent of the Dunnville Hydro-Electric Systems, and Hawkins Guides were a great help to me in holding down a responsible position."

W. E. Swartz, Dunnville, Ontario.

Wireless Operators

"I have worked wireless for ten years—but I wish I had these books years ago, as they have saved me a good deal of trouble."

H. Marshall,
Steamer M & B No. 2,
Walkerville, Ont.

TAKE YOUR ELECTRICITY SUGAR COATED



ENERGIZER
Pains or soreness driven out by flood of pleasant, revitalizing electric spray.



SPINAL TREATMENT
The nerve centers lead this healing stimulation to various organs.



NEURITIS, RHEUMATISM, ETC.
Respond to the vibrant forces of this painless electricity.



NERVE TONIC
Saturates entire system with shockless, soothing RenuLife Violet Ray.



BEAUTY TREATMENTS
Unequaled. Hair, skin and body maintained in attractive health.

Drive Out Aches, Pains and Their Causes

Apply thousands of volts of painless, harmless, high frequency electricity without the slightest shock or unpleasant feeling, just an exhilaration of well-being. Aches, pains, soreness, tired feeling, sub-normal conditions depart and the natural joy of good health is restored. You may now do this at home with

local pain or ache or ailing tissues are directly stimulated while the cause is attacked and the whole system toned and benefited. It's a fundamental treatment working to re-establish normal healthy conditions. That's why it is used and recommended for such a long list of human ills. Get full particulars.

RenuLife Violet Ray High Frequency

Transforms the current from your light socket into this wonderfully effective form of electricity; penetrates deep, saturates entire body; increasing circulation, adding oxygen to the blood, promoting elimination of waste products. The

You Want This FREE BOOK

telling the whole marvelous story of the Violet Ray. Its wonderful successes—its many uses—specified by physicians for rheumatism, neuritis, headache, catarrh, wrinkles, blemishes, falling hair and 100 other bodily ailments and beauty defects, chronic and acute. Get this valuable book by return mail.



NATURE'S OWN AID

What is the strange relation between electricity and life? Some declare electricity is life. We do not know. But life cells do welcome and respond marvelously to electricity in the form of Violet Rays. It works with nature to restore where many other methods fail. For rheumatism, neuritis, nerve and blood disorders, etc., etc.—both chronic and acute. See the list on coupon and ask for full particulars. Blood is brought to area treated—enriched and purified—assimilation and digestion improved—functions restored to normal. Combines the benefits of electricity, vibration, exercise, stimulation and oxidation. Its astonishing low price places it within the reach of all. The *Trial Plan* proves its value in actual use. Receive full information by return mail.

RENULIFE ELECTRIC CO. 1205 MARQUETTE BLDG. Detroit, Mich.

In Canada, Netting Bldg, Windsor, Ont.

DEALERS:—
Write for
Co-operative
Sales Proposition



Several Sizes to Select From

Send For Free Book

RenuLife Electric Co., 1205 Marquette Bldg., Detroit
Please send without obligation your book "Health," explaining Violet Ray treatments with RenuLife Generators; also give full particulars as to its application for ailments checked below.

TREATS SUCCESSFULLY

- | | | |
|------------------------------|------------------------------|--------------------|
| .. Abscesses | .. Falling Hair | .. Paralysis |
| .. Anemia | .. Female Complaints | .. Piles |
| .. Asthma | .. Goitre | .. Pimples |
| .. Arteriosclerosis | .. Gout | .. Pyorrhea |
| .. Baldness | .. Haemorrhoids | .. Rheumatism |
| .. Blackheads | .. Hay Fever | .. Scars |
| .. Brain Fog | .. Infantile Paralysis | .. Sciatica |
| .. Bronchitis | .. Insomnia | .. Skin Diseases |
| .. Bunions | .. Lameness | .. Sore Throat & |
| .. Bruises | .. Locomotor Ataxia | .. Sprains |
| .. Catarrh | .. Lumbago | .. Toothache |
| .. Colds | .. Nervous Affections | .. Weak Eyes |
| .. Chills | .. Neuralgia | .. Wrinkles |
| .. Dandruff | .. Neuritis | .. Warts and Moles |
| .. Deafness and Ear Diseases | .. Obesity | |
| .. Eczema | .. Pain in Abdomen and chest | |
| .. Enlarged Prostate | | |
| .. Facial Neuralgia | | |

Name.....
Address.....